

# I N T E R W E A V E KNITS

SPRING 2011  
interweaveknits.com

*a Spring*

IN YOUR STITCHES

**22** *fresh*  
KNITS FOR  
BREEZY  
DAYS

THINK  
DIFFERENT

Clever Modular  
Construction

Easy, Fast  
Fabrics

Design  
Demystified with  
Shirley Paden

*more*

Fearless Fair Isle  
Mary Jane  
Mucklestone's  
**BEST TIPS**

KALEIDOSCOPE

 Tahki Yarns

KALEIDOSCOPE  
FAIR ISLE CARDIGAN IN  
COTTON CLASSIC LITE

Enter our  
Cotton Classic  
COLOR PLAY  
Challenge!

and sign up for free  
weekly newsletter

[www.tahkistacycharles.com/iwksp11](http://www.tahkistacycharles.com/iwksp11)

Follow TAHKI YARNS on   & 



# contents

Interweave Knits • SPRING 2011 • VOLUME XVI • NUMBER 1

## FEATURES

### 8 Yarn Review: In Season

Larissa Gibson *Protein-cellulose blends are ready for spring.*

### 14 Artist Spotlight: Rachael Matthews

Sabrina Gschwandtner *UFO Administration Service*

### 16 Bookshelf: Design References

Clara Parkes *Who's the designer?*

### 40 Beyond the Basics: Fearless Fair Isle Knitting

Mary Jane Mucklestone *A tip or trick for every Fair Isle conundrum*

### 72 Profile: Shirley Paden In Her Own Words

Bethany Lyttle *Get inside Shirley's designer's workshops.*

77

## PROJECTS

**18 Book Excerpt: Echo from  
A Knitting Wrapsody**  
Kristin Omdahl

### Uncommon Flax

**20 En Pointe Pullover**  
Alice Tang *Instructions page 26*

**21 V-Yoke Cardigan**  
Amy Christoffers *Instructions page 28*

**22 Gathered Front Tank**  
Mercedes Tarasovich-Clark *Instructions page 32*

**23 Heliotropic Pullover**  
Mercedes Tarasovich-Clark *Instructions page 34*

**24 Swirl Crop Jacket**  
Andrea Babb *Instructions page 36*

### Block by Block

**44 Garden Plot Dress**  
Victoria Myers *Instructions page 46*

**45 Cranberry Island Throw**  
Amanda Scheuzger *Instructions page 50*

**45 Hourglass Pillows**  
Daniela Nii *Instructions page 52*

### Fabric Interrupted

**54 Rain on the Prairie Scarf**  
Maureen Hefti *Instructions page 58*

**55 Leaf and Picot Cardigan**  
Laura Grutzeck *Instructions page 58*

**56 Rose Lace Stole**  
Susanna IC *Instructions page 62*

**56 Tatiana's Sweater**  
Raye Schwartz *Instructions page 66*

**57 Drop Mesh Tee**  
Cathy Carron *Instructions page 70*

### Mod\*u\*lar

**76 Curvy Squares Tee**  
Bonnie Paul *Instructions page 80*

**77 Hexagon Petal Tee**  
Maria Leigh *Instructions page 83*

**78 Diminishing Gore Skirt**  
Gwen Bortner *Instructions page 88*

**79 Pinkerton Shawl**  
Susan Dittrich *Instructions page 90*

### Circumnavigated

**92 Lara Bubble Top**  
Faina Goberstein *Instructions page 96*

**93 Draped Vest**  
Carol Feller *Instructions page 98*

**94 Ruched Yoke Tee**  
AnneLena Mattison *Instructions page 100*

**95 Gossamer Smocked Tunic**  
Shelley Gerber *Instructions page 102*

## DEPTS

4 Strands

7 News and Views

106 Glossary

108 Sources for Supplies

118 Advertisers' Index

119 Project Index

120 Ravelings

*Sigrid Arnott*

*On the Cover: Leaf and Picot Cardigan, page 55.  
Photography by Kathryn Martin.*

# THERE'S ALWAYS MORE ONLINE ... @ [interweaveknits.com](http://interweaveknits.com)



< **Real projects. Real knitters.** Follow along as real knitters make and modify patterns in exclusive project diaries.

**Tips, tricks, and answers to all your Fair Isle knitting questions—** up close and in-person with exclusive video how-to.



**See every project in detail:** Click through to see stitch patterns, back views, and much more.

> **The HEXAPETAL TEE** is a study in pure modular knitting. Find out the secrets behind the simpler-than-it-looks lace pattern and eliminating ends to weave in an exclusive sweater workshop!



**Where Life Meets Knitting:** Join the [knittingdaily.com](http://knittingdaily.com) online community for great technique discussions, editor blogs, reader videos and galleries, patterns, forums, and insider information on each issue of *Interweave Knits* and other Interweave publications.

Go online for full schedules and local listings for *Knitting Daily TV!* Go to [knittingdailytv.com](http://knittingdailytv.com) for free projects, tips, designer spotlights, and exclusive bonus videos plus an all-new behind-the-scenes blog from the producers.

Hello, my name is Michelle Hunter.  
I am a knitter.



What is your **addi**ction?



Meet this **addi**ct at:  
[www.skacelknitting.com](http://www.skacelknitting.com)

- addi** Turbo®
- addi** Lace
- addi** Click

Knit-Purl Hunter Knit-Along, featuring  
"20 years of Trekking sock yarn"  
...for details, look to [www.skacelknitting.com](http://www.skacelknitting.com)!



*A little Madness in the Spring  
Is wholesome even for the King.*

—Emily Dickinson



# INTERWEAVE KNITS

Spring 2011

## EDITORIAL

EDITORIAL DIRECTOR Karin Strom  
CONSULTING EXECUTIVE EDITOR Marilyn Murphy  
EDITOR Eunny Jang  
MANAGING EDITOR Laura Rintala  
ASSISTANT EDITOR Larissa Gibson  
PROJECT EDITOR Joni Coniglio  
EDITORIAL ASSISTANT Kathy Mallo  
TECHNICAL EDITORS Karen Frisa, Lori Gayle, Dee Neer  
COPY EDITOR Veronica Patterson

## CREATIVE SERVICES

DESIGNER Kit Kinseth  
PRODUCTION DIRECTOR Trish Faubion  
PRODUCTION COORDINATOR Dean Howes  
PRODUCTION EDITOR Nancy Arndt  
PHOTOGRAPHY  
PROJECTS Kathryn Martin  
FEATURES AND DEPARTMENTS Joe Coda  
PHOTOSTYLING Carol Beaver  
HAIR & MAKEUP Kathryn MacKay  
ILLUSTRATION Gayle Ford, Marjorie Leggitt  
VIDEO MANAGER Garrett Evans

## PUBLISHING

GROUP PUBLISHER John P. Bolton  
MEDIA SALES DIRECTOR Julie Macdonald  
ADVERTISING MANAGERS Marcy Bradford, Diane Kocal  
AD TRAFFICKERS Melissa Marie Brown, Tina Rolf  
CLASSIFIED ADVERTISING Stephanie Griess  
MARKETING MANAGER Annie Hartman Bakken  
CIRCULATION MANAGER Jodi Smith

Projects and information are for inspiration and personal use only. We've made every effort to ensure the accuracy of the contents of this publication. However, human errors do occur. If you have questions regarding a pattern in this issue, please visit us online at [www.interweaveknits.com/corrections](http://www.interweaveknits.com/corrections).

*Interweave Knits* does not recommend, approve, or endorse any of the advertisers, products, services, or views advertised in *Knits*. Nor does *Knits* evaluate the advertisers' claims in any way. You should, therefore, use your own judgment in evaluating the advertisers, products, services, and views advertised in *Knits*.

*Interweave Knits* (ISSN 1088-3622) is published quarterly by Interweave Press LLC, 201 E. Fourth St., Loveland, CO 80537-5655. (970) 669-7672. USPS #017-249. Periodicals postage paid at Loveland, CO 80538, and additional mailing offices. All contents of this issue of *Interweave Knits* are copyrighted by Interweave Press LLC, 2011. All rights reserved. Projects and information are for inspiration and personal use only. Reproduction in whole or in part is prohibited, except by permission of the publisher. Subscription rate is \$26.95/one year in the U.S., \$30.95/one year in Canada, and \$33.95/one year in international countries (surface delivery). U.S. funds only.

POSTMASTER: Please send address changes to Interweave Knits, PO Box 469117, Escondido, CA 92046-9117.

Visit the Interweave website at [interweave.com](http://interweave.com). For advertising information, call Julie Macdonald at (970) 613-4612, e-mail [jmacdonald@interweave.com](mailto:jmacdonald@interweave.com), or visit the website at [interweave.com](http://interweave.com). For sales information, call (800) 272-2193, e-mail [sales@interweave.com](mailto:sales@interweave.com). For editorial inquiries, call (800) 272-2193, e-mail [knits@interweave.com](mailto:knits@interweave.com), or write to 201 E. Fourth Street, Loveland, CO 80537-5655.



February is an odd in-between month. In other languages and at other times it's been called Cabbage Month, Mud Month, Ice Month—the month of hard, harsh weather and patient waiting for renewal. Gardeners dog-ear seed catalogs and set up trays indoors, dreaming of ground that can be worked—gastronauts wait for the area's first bursting-with-chlorophyll asparagus—baseball nuts dig in to watch chilly spring training sessions, with their promise of hot sunshine and long days in the not-too-distant future.

We knitters, though, we've found the secret to waiting out February with good grace: We take up projects that hint at spring with bright colors and light fabrics, willing warmer days with every stitch. We shed our wooly skins and try on cottons, linens, and silks; we experiment; we replace heavy, serious expeditions into knitting with playful jaunts. All through the dreary midwinter, we knit on, leaving a trail of brightly colored freshness. How could spring fail to come? We knitters earn it honestly.

With that in mind, we've stocked this issue of *Interweave Knits* with all the right projects to get you dreaming about spring: flowing, sculptural knits that take advantage of linen's drape ("Uncommon Flax," page 20); punchy modern color-block knitting ("Block by Block," page 44); gently sophisticated lace projects ("Fabric Interrupted," page 54); fun modular knits ("Mod\*u\*lar," page 76), and fresh, sweet ruffles and ruching ("Circumnavigated," page 92). Let the snow fall—we're busy getting ready for daffodils.

Happy Knitting,

Eunny



### P.S.

AN EXTRA SPECIAL THANK YOU to Judith Buckle, who made our shoot possible—thanks for opening your lovely home to us.

# Knit the Characters, Tell the Story!

From Susan B. Anderson, the imaginative creator of the *Itty-Bitty* books, comes an adorable new idea in knitting books. Meet Spud and Chloë and their barnyard friends, and, while you knit them, read the story aloud to a favorite child.



*Spud & Chloë at the Farm*  
will be available Spring 2011





**Linsey™**

Ultra soft cotton & linen in  
gently shifting multicolor  
shades & sun-weathered solids



**bayarri**  
knit in Linsey from  
Booklet #307 Linsey

For details, go to [www.berroco.com](http://www.berroco.com)  
and enter "bayarri" in our search box.

 **BERROCO®**  
[www.berroco.com](http://www.berroco.com)

 **INTERWEAVE.**  
Independent Publishers Since 1975

**FOUNDER**  
Linda Ligon

**CEO**  
Clay B. Hall

**CFO**  
Troy Wells

**SENIOR VPS**  
John P. Bolton  
Bob Kaslik  
Stephen Koenig

**VP, EVENTS & EDUCATION**  
Sara Dumford

**VP, PEOPLE OPERATIONS**  
Aaron Wilmot

**VP, PRODUCTION**  
Trish Faubion

**VP, TECHNOLOGY**  
T.J. Harty

**VP, PUBLISHER, ART &  
JEWELRY DIVISION**  
David Pyle

**MAGAZINES**

Fiber Division  
*Cloth, Paper, Scissors*  
*Fiberarts*  
*Handwoven*  
*Interweave Crochet*  
*Interweave Knits*  
*PieceWork*  
*Quilting Arts*  
*Spin-Off*

**ONLINE**

*Knitting Daily*  
**EDITOR**  
Kathleen Cubley

**BOOKS**

**PUBLISHER**  
Stephen Koenig  
**EDITORIAL DIRECTOR**  
Marlene Blessing  
**ACQUISITIONS EDITOR**  
Allison Korleski  
**ART DIRECTOR**  
Liz Quan  
**PRODUCTION DIRECTOR**  
Kristen Heller

For questions regarding our book  
program, call (970) 669-7672  
Monday–Friday, 8:00 A.M.–5:00 P.M.,  
or e-mail [books@interweave.com](mailto:books@interweave.com)



**ASPIRE  
MEDIA**

An Aspire Media company

**SUBSCRIBERS:** Have a question about your *Interweave Knits* subscription? We have the answer. Visit our website, e-mail, call, or fax your question, and we'll be happy to assist you. Go to [www.interweaveknits.com](http://www.interweaveknits.com) and click on Subscribe for new subscriptions, renewals, gift orders, and to change your address, pay your bill, and to submit subscription questions or concerns.

*Interweave Knits* Subscription Services  
E-mail Address: [interweaveknits@pcspublink.com](mailto:interweaveknits@pcspublink.com)  
U.S. & Canadian Customer Service: (800) 835-6187  
International Customer Service: (760) 291-1531  
Fax Number: (760) 768-4805  
Mail: PO Box 469117, Escondido, CA 92046-9117

Please allow six weeks for processing address changes. Your customer number on the address label is your key to the best service possible. Please include it with all correspondence to avoid delays or errors.

Interweave Press LLC Main Office  
201 East Fourth Street • Loveland, Colorado 80537 • (970) 669-7672

Visit our website [interweaveknits.com](http://interweaveknits.com)





Top: Knitter's graph paper—input your gauge, print, and go. *Knitter's Graph Paper*, [www.thediary.com/knittingfiend/KnittersGraph.html](http://www.thediary.com/knittingfiend/KnittersGraph.html).

Keep track of swatches and label gifts with knitty gift tags by Pat Aubé Gray. *Gift Tags*, [www.pataubegraystudios.com](http://www.pataubegraystudios.com).



Good reference books: Every knitter's best friends. *The Handknitter's Handbook* by Montse Stanley (David & Charles, 1986). *Knitting Block By Block* by Nicky Epstein (Potter Craft, 2010).

new&notable

# Who's the designer?

Get inspired, jot it down, and cast on.

SHARON ZIENTARA & LARISSA GIBSON



Every tool you need for swatching (and knitting), all in one place. *The Knit Kit*, [www.knitkit.com](http://www.knitkit.com).



Be ready when inspiration strikes with tiny yarn-themed notepad holders. *Notepad Holders*, [www.lanternmoon.com](http://www.lanternmoon.com).

A notebook that has it all: Blank pages for sketching, graph paper, and lined sheets, with the occasional tip or thought from Elizabeth Zimmermann to boot. *Knitter's Journals*, [www.schoolhousepress.com](http://www.schoolhousepress.com).



# IN SEASON

LARISSA GIBSON

*What do you get when you cross a sheep with . . . a cotton ball? A delightful outcome for knitters everywhere! Although the art of blending animal fibers and cotton is likely as old as the fibers themselves, a new crop of blends offers knitters some uncommonly fine choices.*

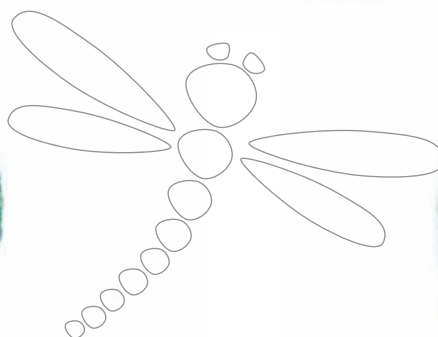
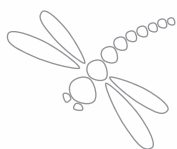

## Misti Alpaca Tonos Pima Silk

*Content: 83% pima cotton, 17% silk • Put-Up: 327 yd [299 m]/100 g • Construction: 4 ply • Care: Handwash in cold water, dry flat, iron on low heat, or dry-clean • Recommended Gauge: 5–5.5 sts = 1" on size 4–6 (3.5–4 mm)*

Tonos Pima Silk is the only silk blend in this group, and the distinction is apparent. It has a very different hand. The hand is still soft but also what may best be described as dry, hinting at the scrunchiness of a crisp silk taffeta. The luster is muted in the skein, but, once the yarn is knitted, light bounces between the colors, creating an iridescent effect. The colors are rich and jewel-like. The silk in this blend adds a sparkle, a crispness, and a hint more warmth to the buttery-soft cotton.

## Rowan Belle Organic DK

*Content: 50% organic wool, 50% organic cotton • Put-Up: 131 yd [120 m]/50 g • Construction: Seven 2-ply strands • Care: Handwash in cold water, dry flat in shade, iron on low heat, or dry-clean in certain solvents • Recommended Gauge: 22 sts and 30 rows = 4" on size 6 (4 mm)*

This yarn will help you fulfill all your good intentions about going organic. There are no compromises here; this yarn is both snugly soft and springy. The subtle difference in color between the cotton and the wool gives the yarn a lively sheen, and the color palette serves up appetizing spring/summer shades. I envision an array of spring-y little cardigans and shrugs in this yarn, with the wool content encouraging an early debut.

## Manos del Uruguay Serena

*Content: 60% baby alpaca, 40% pima cotton • Put-Up: 170 yd [155 m]/50 g • Construction: 3 ply • Care: Handwash, dry flat, or dry-clean • Recommended Gauge: 22–26 sts = 4" on size 5–6 (3.75–4 mm)*

The lightest in this group of yarns, Serena is delicate and baby soft. It retains the loft and smooth hand of a good alpaca yarn. And, although Serena's alpaca content adds warmth, its cotton content ensures that your garments will be perfect for temperate spring weather.

You'll feel good about using this yarn for its own sake, but if you need another reason, Manos del Uruguay is certified by the World Fair Trade Organization and committed to sustainable economic development for its yarn producers. For the full story, go to [www.fairmountfibers.com](http://www.fairmountfibers.com).

*Larissa Gibson* is the new assistant editor for *Interweave Knits* and a longtime fan of all things fiber. Look for her contributions in future issues.

Typically, the knitter must choose between wool or cotton, animal or vegetable, warm weather or cool, next to skin or over layers, easy care or delicate, soft or coarse, firm or elastic, and the list goes on. With the yarns covered in this review, a range of possibilities in the middle opens up. Perhaps one of these yarns will become your choice for the sweater that wakes up in snow and walks home amid daffodils.

Protein fibers, or fibers of animal origin, are best known for their thermal-insulating warmth, elasticity, and resilience. Garments made from them keep us warm, stretch and recover (retaining their original shape), and resist wrinkling. Cellulose fibers, or fibers of plant origin, are best known as thermal conductors, allowing body heat to escape, making

for comfortable warm-weather attire. Except for their greater tendency to wrinkle, cellulose-fiber fabrics are easier to care for than protein-fiber fabrics. Cellulose fibers are actually stronger when wet than when dry, and they're resistant to the alkaline elements common to most detergents, making them well suited to home laundering. When wrinkles do occur, cellulose fibers tolerate a hot iron better than other fibers.

These cellulose/protein blend yarns combine attributes of both types of fiber, producing fabrics well suited to spring. Although these yarns superficially resemble their 100% cotton cousins, the protein content makes them feel a little warmer, lighter, and bouncier. On the downside, none of the yarns can be machine washed.

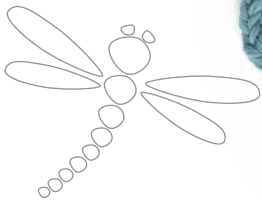

### Artyarns Cottonspring

*Content: 80% cotton, 20% wool • Put-Up: 165 yd [151 m]/50 g • Construction: 2-ply binder plied with thicker singles • Care: Handwash in cold water, dry flat in shade, iron on low heat, or dry-clean • Recommended Gauge: 5.5 sts = 1" on size 6 (4 mm)*

Cottonspring is an interesting combination of disparate components, a thin 2-ply wool binder twisted with a thicker, lightly spun cotton. The combination produces a soft yet textured surface with tons of visual interest. Cottonspring has the most luster of any yarn in this group. The luster combines with multicolor handpainting for an eye-catching effect.

In Cottonspring, the wool adds structure, allowing the soft-spun cotton to bloom, drape gracefully, and reflect more light. The visual features combined with the cottonball hand make this a great yarn for anything from decorative accents to baby blankets.

### Brown Sheep Cotton Fleece

*Content: 80% cotton, 20% merino wool • Put-Up: 215 yd [197 m]/100 g • Construction: Cable (four 3-ply strands of 2 ply) • Care: Handwash in cool water, dry flat, cool iron, or dry-clean • Recommended Gauge: 5 sts = 1" on size 6 (4 mm)*

The heaviest of the yarns reviewed, this unassuming yarn knits up beautifully. Because there's nothing flashy about it you might walk by without noticing it but give it a second look. The stitch definition is remarkable, and the yarn begs to be shown off in cables and textured stitch patterns. It retains the overall hand of cotton, but the wool lends added warmth and a little more shape retention than a classic cotton. If you love the look of Aran sweaters but want something a little lighter or with a lot less wool, this yarn is a good choice.

### Karabella Lacampo

*Content: 60% dehaired llama, 40% cotton • Put-Up: 136 yd [124 m]/50 g • Construction: Three 2-ply strands • Care: Handwash in cold water, dry flat, iron on low heat, or dry-clean • Recommended Gauge: 22 sts and 28 rows = 4" on size 6 (4 mm)*

This yarn will have you rethinking what you know about llama. Throw out that vision of the coarse saddle blanket. The dehairing process removes all of the long coarse fibers from the coat, leaving the soft, downy undercoat. The fiber is more like camel down than saddle-blanket yarn. Lacampo is next-to-the-skin soft and contains small white flecks of undyed fiber that give it a muted heather appearance. In the skein, it resembles a thirsty bath towel, but given the high protein-fiber content, I won't be making any bath items from this yarn, except, perhaps, a luscious wrap for a walk to an outdoor sauna.



2011G Swarthmore



2011A Albright



2011B Bryn Mawr

# serena

60% alpaca, 40% cotton

new patterns for spring 2011



MANOS  
DEL URUGUAY

Wool Clasica - Silk Blend - Rittenhouse Merino 5-Ply - Serena - Maxima - Lace



2011 E Lafayette



2011 F Moore



2011 C Tyler

#### ARIZONA

Tucson Yarn Company | Tucson | 520-229-9276 | [tucsonyarn.com](http://tucsonyarn.com)

#### ARKANSAS

Hand Held | Fayetteville | 479-582-2910 | [handheldknitting.com](http://handheldknitting.com)  
Yarn Mart | Little Rock | 501-666-6505 | [yarnmart.com](http://yarnmart.com)

#### CALIFORNIA

Alamitos Bay Yarn Co | Long Beach | 562-799-8484 | [yarncompany.com](http://yarncompany.com)  
Anacapa Fine Yarns | Ventura | 850-654-9500 | [anacapafineyarns.com](http://anacapafineyarns.com)  
Ball & Skein & More | Cambria | 805-927-3280 | [cambriayarn.com](http://cambriayarn.com)  
Colors 91711 | Claremont | 877-659-1711 | [colors91711.com](http://colors91711.com)  
Knit & Pearl Boutique | Santa Barbara | 805-963-3930  
Monarch Knitting & Quilts | Pacific Grove | 888-575-9276 | [monarchknitting.com](http://monarchknitting.com)  
Wild Fiber | Santa Monica | 800-382-7067 | [wildfiber.com](http://wildfiber.com)  
Yarndogs | Los Gatos | 408-399-1909 | [yarndogs.com](http://yarndogs.com)

#### COLORADO

Find Your Stash | Castle Rock | 303-660-9276 | [fystash.com](http://fystash.com)  
Shuttles, Spindles, & Skeins | Boulder | 800-283-4163 | [shuttlespindlesandskeins.com](http://shuttlespindlesandskeins.com)

#### CONNECTICUT

Nancy O | Ridgefield | 203-431-2266 | [shopnancyo.com](http://shopnancyo.com)

#### FLORIDA

A Good Yarn | Sarasota | 941.487.7914 | [agoodyarnsarasota.com](http://agoodyarnsarasota.com)

#### ILLINOIS

The Fold | Marengo | 815-568-5730 | [thefoldatmc.net](http://thefoldatmc.net)  
Three Bags Full | Northbrook | 847-291-9933 | [threebagsfullknittingstudio.com](http://threebagsfullknittingstudio.com)  
Wool & Company | St. Charles | 630-232-2305 | [woolandcompany.com](http://woolandcompany.com)

#### INDIANA

Sheep Street Fibers | Martinsville | 812-597-KNIT | [sheepstreet.com](http://sheepstreet.com)  
Sheep's Clothing | Valparaiso | 219-462-1700 | [knitdoctor.com](http://knitdoctor.com)

#### IOWA

The Yarn Shoppe | Davenport | 563-359-1002 | [theyarnshoppe.net](http://theyarnshoppe.net)

#### MARYLAND

All About Yarn | Columbia | 410-992-5648 | [allaboutyarn.com](http://allaboutyarn.com)  
Cloverhill Yarn Shop | Baltimore | 410-788-7262 | [cloverhill yarn.com](http://cloverhill yarn.com)  
Ewenique Yarns | Bel Air | 410-399-9929 | [eweniqueyarns.com](http://eweniqueyarns.com)  
Knit + Stitch = Bliss | Bethesda | 866-563-3353 | [knitandstitch.com](http://knitandstitch.com)

#### MASSACHUSETTS

A Good Yarn | Brookline | 617-731-4900 | [agoodyarn.biz](http://agoodyarn.biz)  
Fiber Loft | Harvard | 978-456-8669 | [thefiberloft.com](http://thefiberloft.com)  
Knit Purl | Sudbury | 978-443-5648 | [knitpurlsudbury.com](http://knitpurlsudbury.com)  
Knit Witts | Brookfield | 877-877-5648 | [knitwitts.com](http://knitwitts.com)  
Wild & Woolly | Lexington | 781-861-7717  
Windsor Button | Boston | 617-482-4969 | [windsorbutton.com](http://windsorbutton.com)  
Wonderful Things | Great Barrington | 413-528-2473 | [wonderful-things.com](http://wonderful-things.com)

#### MICHIGAN

Threadbear Fiber Arts | Lansing | 866-939-2327 | [threadbearfiberarts.com](http://threadbearfiberarts.com)

#### MINNESOTA

Amazing Threads | Maple Grove | 763-391-7700 | [amazing-threads.com](http://amazing-threads.com)  
3 Kittens Needle Arts | St. Paul | 651-457-4969 | [3kittensneedlearts.com](http://3kittensneedlearts.com)

#### MONTANA

Joseph's Coat | Missoula | 406-549-1419 | [josephscoat yarns.com](http://josephscoat yarns.com)  
Stix | Bozeman | 406-556-5786 | [stixyarn.com](http://stixyarn.com)

#### NEW HAMPSHIRE

Elegant Ewe | Concord | 603-226-0066 | [elegantewe.com](http://elegantewe.com)  
Yarn Basket | Portsmouth | 603-431-9301 | [yarnbasket.com](http://yarnbasket.com)

#### NEW JERSEY

Knit-a-Bit | Westfield | 908-301-0053 | [knit-a-bit.com](http://knit-a-bit.com)  
The Skein Attraction | Teaneck | 201-836-5648 | [theskeinattraction.com](http://theskeinattraction.com)  
Woolbearers | Mt. Holly | 609-914-0003 | [woolbearers.com](http://woolbearers.com)  
Woolly Lamb | Pennington | 609-730-9800 | [thewoollylamb.com](http://thewoollylamb.com)

#### NEW YORK

Flying Fingers | Tarrytown | 877-359-4648 | [flyingfingersyarnshop.com](http://flyingfingersyarnshop.com)  
Knit | Roslyn | 516-625-KNIT | [knitlongisland.com](http://knitlongisland.com)  
Purl | New York | 212-420-8796 | [purlsoho.com](http://purlsoho.com)

#### NORTH CAROLINA

Earth Guild | Asheville | 800-327-8448 | [earthguild.com](http://earthguild.com)

#### OREGON

Close Knit | Portland | (503)288-4568 | [closeknitportland.com](http://closeknitportland.com)  
Stitchin' Post | Sisters | 541-549-6061 | [stitchinpost.com](http://stitchinpost.com)  
Websters | Ashland | 800-482-9801 | [yarnatwebsters.com](http://yarnatwebsters.com)

#### PENNSYLVANIA

Mannings | E. Berlin | 800-233-7166 | [the-mannings.com](http://the-mannings.com)  
Rosie's Yarn Cellar | Philadelphia | 215-977-9276 | [rosiesyarncellar.com](http://rosiesyarncellar.com)

#### RHODE ISLAND

Fresh Purls | Providence | 401-270-8220 | [freshpurls.com](http://freshpurls.com)  
The Mermaid's Purl | North Kingstown | 401-268-3899 | [themermaidspurl.com](http://themermaidspurl.com)

#### VERMONT

Northern Nights | Norwich | 802-649-2000

#### VIRGINIA

Aylin's Woolgatherer | Falls Church | 800-775-9665 | [aylins-wool.com](http://aylins-wool.com)  
Hunt Country Yarns | The Plains | 540-253-9990 | [skeins.com](http://skeins.com)  
The Knitting Corner | Virginia Beach | 757-420-7547 | [theknittingcorner.com](http://theknittingcorner.com)  
Knitting Sisters | Williamsburg | 757-258-5005 | [knittingsisters.com](http://knittingsisters.com)  
Never Enough Yarn | Winchester | 540-665-1800 | [neverenoughyarn.biz](http://neverenoughyarn.biz)  
Uniquities | Vienna | 888-465-5648 | [uniquitiesyarnshop.com](http://uniquitiesyarnshop.com)

#### WASHINGTON

Apple Yarns | Bellingham | 360-756-9992 | [appleyarns.com](http://appleyarns.com)  
Churchmouse Yarns & Teas | Bainbridge Island | 206-780-2686 | [churchmouseyarns.com](http://churchmouseyarns.com)  
Fiber Gallery | Seattle | 206-706-4197 | [fibergallery.com](http://fibergallery.com)  
Seattle Yarn Gallery | Seattle | 206-935-2010 | [seattleyarn.com](http://seattleyarn.com)  
Weaving Works | Seattle | 888-524-1221 | [weavingworks.com](http://weavingworks.com)

#### WISCONSIN

The Cat & Crow | Mount Horeb | 608-437-1771 | [thecatandcrowonline.com](http://thecatandcrowonline.com)  
Spin | Sturgeon Bay | 920-746-7746 | [spinofdoorcounty.com](http://spinofdoorcounty.com)

## Fairmount Fibers Ltd.

[www.fairmountfibers.com](http://www.fairmountfibers.com) | [info@fairmountfibers.com](mailto:info@fairmountfibers.com) | 888.566.9970

In Canada: CNS Yarns Inc. | 514.276.1204 | [info@cnsyarns.com](mailto:info@cnsyarns.com) | [www.manoscanada.com](http://www.manoscanada.com)

## Yarn Spotlight

**A BLEND FOR ALL SEASONS**

Meet Tahki Coast: A grown-up cotton-wool blend that retains the best characteristics of both the fibers it contains. Fine wool lends bounce and memory while cotton contributes drapey weight and strength. The result is a worsted-weight yarn with great stitch definition, a dry hand that feels good against sensitive skin, and temperature neutrality—perfect for all-season knits. Available in fourteen misty heathered shades achieved by exploiting the different dye-absorption rates of wool and cotton, Coast is a natural for casual knits to wear every day, all year long. [www.tahkistacycharles.com](http://www.tahkistacycharles.com)

## Product Spotlight

**NEEDLES TO SWOON OVER**

Montana Mountain Exotics knitting needles from Books, Yarn & More make knitting a multi-sensory experience. Handmade in a range of exotic hardwoods with rich colors and random grain patterns, the needles are a pleasure to look at, touch, and listen to. You may reach for their inviting smoothness just for the pleasure of rolling them in your hand, but you'll find that they also have just the right amount of grip on your stitches. Once you're knitting, you'll notice the quiet, gentle click of wood against wood with each stitch. Add in the lifetime break-and-replace guarantee, and these knitting needles are hard to resist. Available in a range of lengths and sizes, both single and double-pointed. [www.booksyarnmore.com](http://www.booksyarnmore.com)





Pattern 133.48  
Quality SONORA  
Aloés

Pattern taken from  
our magazine  
Spring/Summer 157  
available at your stockist's

visit [www.bergeredefrance.com](http://www.bergeredefrance.com)  
for your nearest retailer

BERGERE  
de France

Tél. 1 800 361-0090 - Fax (1) 450-655-1272 - [info@bergeredefrance.us](mailto:info@bergeredefrance.us) - [www.bergeredefrance.com](http://www.bergeredefrance.com)  
Mobile 07968 536333 - Tel/Fax 01606 883149 - email: [gordonjleslie@bergeredefrance.co.uk](mailto:gordonjleslie@bergeredefrance.co.uk)

ARTIST SPOTLIGHT

# Rachael Matthews



## UFO Administration Service



< A shoulder and half bust of a camisole was knitted into a windmill by Louise Harries. Above: Pudding Man wasn't finished in time for Christmas; he will be sent to Dierdre Nelson. All Images Courtesy of UFO Project Administration Service.

S A B R I N A G S C H W A N D T N E R

**Rachael Matthews**, known for her knitting club for boys and girls, *Cast Off* ([www.castoff.info](http://www.castoff.info)), her book *Knitorama* (M Q Publications, 2005), and her London-based haberdashery shop, *Prick Your Finger*, noticed an affliction spreading across the knitting community. “Across the world, hidden in cupboards, are accumulations of half-knitted works,” she explains. “On conception, the ideas were fueled by love and contemplation. For various reasons, the projects have stalled. The patterns may be lost and the yarn have run out, but, with invested hours of skilled effort, these pieces are rarely thrown away. They are packed and hidden away, harboring guilt and sorrow.”

In 2007, Rachael inherited a bag of unfinished pieces made by Carolyn Rawlinson, founder of Woolfest ([www.woolfest.co.uk](http://www.woolfest.co.uk)), who had passed away. “If there is a God of Knitting,” Rachael says, “it was upon my receipt of this bundle that she pressed a great weight upon my shoulders and advised me to start the UFO Project Administration Service.”



A UFO flying in, used on the project's website.

Rachael's service accepts UnFinished Objects (UFOs) of any kind, archives them, and offers them to knitters who are willing to complete them. The project's first phase took place at the Jerwood Contemporary Makers exhibition in 2009. For that show, Rachael made a small website and an application form, inviting knitters to donate and adopt pieces, as well as share their stories of how the works had become stalled or been completed. Displayed projects included one shoulder of a camisole finished as an abstract piece that resembles a windmill, and a small rectangle turned into a scarf with crocheted ends.

Now an ongoing project, the UFO Project Administration Service offers unfinished knits such as half a sweater, a stalled plant potholder, and a sleeve, back, and partial front of a child's fairy costume. “The project is a fascinating study of problem-solving in knitting,” says Rachael, who hopes to complete the project as a book that showcases the brilliant ways knitters think.

For more information or to donate or adopt a UFO, please visit [www.ufoadministration.blogspot.com](http://www.ufoadministration.blogspot.com). ■

*Sabrina Gschwandtner* is a New York-based visual artist and author of *Knitknit: Profiles and Projects from Knitting's New Wave* (Stewart, Tabori & Chang, 2007).



make time  
for yarn  
every day



Meet technician turned tastemaker Lisa Shroyer, the knitter we would all like to be.

Knitscene, a special issue from Interweave full of stylish, spirited knits, goes quarterly in 2011. You'll get more of editor Lisa's inimitable style—good knitting spiked with quirky fashion influences—than ever before.

Lisa's new book, *Knitting Plus* (Interweave, 2011), is full of deep technical know-how, design inspiration, and original patterns to flatter and celebrate plus-sized figures.

Series 600 of *Knitting Daily TV* features Lisa on location at The National Needlearts Association (TNNA) trade show, exploring what makes different sweater constructions tick.

Check out Lisa's thoughts on fashion, knitting technique, and their intersection at the *Inside Knitscene* blog, [knittingdaily.com/blogs/knitscene](http://knittingdaily.com/blogs/knitscene).



# Intwined

## Pattern Studio

Chart Design Software

Share and publish your own designs anywhere—blogs, books and friends!

User-friendly—just bring your creativity.

*“Creating a chart is simplicity itself.”*

The Knitter

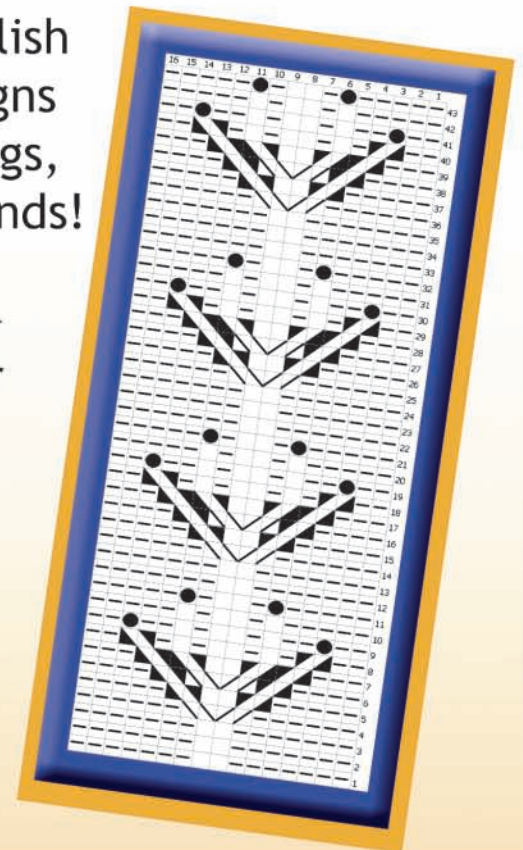

*“Very user-friendly...fabulous!”*

Jordana Paige

*“It's a bargain—I'll take three!”*

Lily Chin

JUST  
\$44

[www.IntwinedStudio.com](http://www.IntwinedStudio.com)  
800-339-0625

Use code KWXA for \$4 off



# Design References

*Knitting from your own pattern can be exciting. And if your calculations don't work out, what's the worst that can happen? Although you can't rescue a failed soufflé, you can catch and fix your knitting mistakes as you go along. And the satisfaction of completing an item entirely of your own creation? Priceless.*

CLARA PARKES

Until recently, basic knitwear design skills were passed down from generation to generation or taught in schools. Today, we rely on books, video tutorials, and individual teachers to show us the way. Classic books from Jacqueline Fee, Deborah Newton, Maggie Righetti, Barbara G. Walker, and Elizabeth Zimmermann remain in print, and for good reason. Now, let's look at a few more recent releases that join their ranks and can help you on your own designing path.

- Sharon Turner's **Teach Yourself Visually Knitting Design: Working from a Master Pattern to Fashion Your Own Knits** (Visual, 2007) follows the highly templated Teach Yourself Visually format. Abundantly illustrated master patterns serve as training wheels to help you understand basic construction techniques for scarves and shawls, sweaters and vests, hats, bags, and socks, as well as mittens, gloves, and handwarmers. Not until Chapter 10—after a brief discussion about how to alter these master patterns—does Turner finally set you loose to design your own knits from scratch. But if you want those training wheels, *Teach Yourself Visually Knitting Design* is a great start.



- If you're ready to study sweaters more closely, consider Cheryl Brunette's **Sweater 101: How to Plan Sweaters That Fit . . . And Organize Your Knitting Life at the Same Time** (Marrowstone Island Press, 2008). Originally published in 1991 and recently brought back into print, this clear, straightforward book

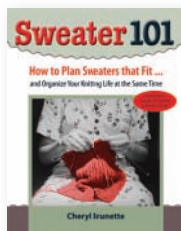

demystifies the drop-sleeve, set-in sleeve, and raglan sweater styles. She talks all about math, gauge, sizing, and how to chart what she calls "picture patterns," which are presented visually rather than verbally. You'll also find schematics and worksheets for sweaters sized to fit everyone from a six-month-old child to a man with a 50-inch chest.

- When you're ready for the ultimate sweater master class, turn to Shirley Paden's **Knitwear Design Workshop: A Comprehensive Guide to Handknits** (Interweave, 2010). The weighty, wire-bound volume isn't one to be read passively—Paden puts you to work figuring out your design goals, taking measurements, and calculating vital numbers. But she also provides several complete patterns for elegant couture projects that serve as examples of different design silhouettes. You won't find instructions for hats, socks, mittens, or totes here. Paden focuses on sweaters, jackets, suits, dresses, and what she calls formalwear. Practice Paden's design and finishing techniques and you'll achieve high-couture mastery on your own needles.



- What Diana Kennedy did for Mexican cooking and Julia Child for French food, Barbara G. Walker did for countless knitters in her *Knitting from the Top*. She showed knitters how to conceive, design, and knit projects using the clever and efficient top-down knitting technique. In 2010, Walker passed the top-down baton to Kristina McGowan, even providing the forward



for McGowan's book **Modern Top-Down Knitting: Sweaters, Dresses, Skirts & Accessories Inspired by the Techniques of Barbara G. Walker** (STC Craft: A Melanie Falick Book, 2010). The new book applies Walker's techniques to an assortment of contemporary silhouettes including dresses, tunics, skirts, cardigans, pullovers, hats, and mitts. McGowan also gives invaluable technique details and finishing tips for a true couture look.

- Although numerous helpful knitwear design technique books are available, far fewer books offer insight into a successful designer's creative process—Debbie Bliss's **Design It, Knit It: Secrets from the Designer's Studio** (Sixth&Spring, 2009) being a recent exception. What at first glance looks like another collection of Bliss's attractive patterns is actually a thoughtfully narrated walk through her design process. The book is structured by theme—designing for the body, using color, adding texture, designing for kids, and so forth. Bliss explains her approach to each theme, adding personal stories and illustrating her point with abundant swatches, before providing three different patterns that illustrate nuances within each theme. The book offers a brief but insightful glimpse into the creative kitchen of this extremely prolific knitwear designer.



When she doesn't have her nose in a book or a skein of yarn, *Clara Parkes* publishes her weekly online knitting magazine, [www.knittersreview.com](http://www.knittersreview.com). She is also the author of *The Knitter's Book of Yarn* and *The Knitter's Book of Wool* (Potter Craft, 2007 and 2009, respectively).

ROWAN



# Savannah Collection

12 designs for Women using Savannah by Marie Wallin



*"The Rowan 'Savannah Collection' embraces the key trend for relaxed easy to wear knits that drape and also fit the body silhouette. The new Rowan Savannah yarn is perfect for this trend as it has a lovely dry summery hand and is cool to the touch."* Marie Wallin Director of Design for Rowan

Pampas



Savannah



Dune

**North America:**

Westminster Fibers,  
8 Shelter Drive,  
Greer, SC 29650  
Tel: 800 445 9276  
rowan@westminsterfibers.com

ROWAN

www.knitrowan.com

**UK:**

Rowan  
Tel: +44 (0)1484 681881  
mail@knitrowan.com

**Australia:**

Australian Country Spinners  
Tel: 3 9380 3888  
sales@auspinners.com.au



*A Knitting Wrapsody* by Kristin Omdahl celebrates cozy knitting and classic style. Echo tweaks a simple shape with lush texture, updating an everyday basic. *A Knitting Wrapsody* (Interweave, 2011, \$24.95) is available at your local yarn or book store or online at [interweavestore.com](http://interweavestore.com).



# echo

## reversible drop-stitch möbius

KRISTIN OMDAHL

*Worked in a reversible fabric, both the right and wrong sides of this Möbius wrap look the same. To showcase the unusual texture of the beautiful yarn, I incorporated dropped stitches—which form simple unstitched yarn and ensure a pretty drape. For versatility, I worked this project in a flat piece and added buttons on the right and wrong sides so that it could be fastened with or without the Möbius twist. Twisted and secured, you've got a Möbius. Straight and secured with one or two buttons, you've got a capelet. Wrapped twice around the neck and secured with one or two buttons, you've got a cowl. Flat and gorgeous all on its own, you've got a reversible scarf!*

### MATERIALS

**Finished Size** About 10" (25.5 cm) wide and 38" (96.5 cm) long, relaxed after blocking. **Note:** The ribbing and dropped stitches make this fabric very stretchy.

**Yarn** Chunky weight (#5 Bulky). Shown here: Tahki Stacy Charles Loop-D-Loop Granite (95% merino, 5% nylon; 55 yd [50 m]/50 g): #002 Mahogany, 4 balls.

**Needles** Size U.S. 13 (9 mm): 24" (60 cm) circular (cir). Adjust needle size if necessary to obtain the correct gauge.

**Notions** Cable needle (cn); tapestry needle; six 1" (2.5 cm) buttons (buttons shown are JHB #1670 available at [www.JoAnn.com](http://www.JoAnn.com)).

**Gauge** 12-stitch cable = 2½" (6.5 cm) wide; dropped stitch = 1¼" (3.2 cm) wide.

**Note:** This fabric is very stretchy; exact gauge is not critical.

### NOTE

- See the accompanying DVD for a demonstration on working the chain-2 bind-off.

### Stitch Guide

**2/2LC (worked over 8 sts):** Slip 4 sts onto cn and hold in front of work, work next 4 sts as [k1, p1] 2 times, work 4 sts from cn as [k1, p1] 2 times.

**2/2RC (worked over 8 sts):** Slip 4 sts onto cn and hold in back of work, work next 4 sts as [k1, p1] 2 times, work 4 sts from cn as [k1, p1] 2 times.

### SCARF

CO 38 sts.

**Row 1:** [K1, p1] 6 times, \*k1, [k1, p1] 6 times; rep from \* once.

**Rows 2, 3, and 4:** Rep Row 1.

**Row 5:** 2/2LC (see Stitch Guide), [k1, p1] 2 times, \*k1, 2/2LC, [k1, p1] 2 times; rep from \* once.

**Rows 6–10:** Rep Row 1.

**Row 11:** [K1, p1] 2 times, 2/2RC (see Stitch Guide), \*k1, [k1, p1] 2 times, 2/2RC; rep from \* once.

**Row 12:** Rep Row 1.

Rep Rows 1–12 ten more times, then rep Rows 1 and 2 once more—piece measures about 37" (94 cm) from CO.

**Next row:** (Buttonhole row) [K1, p1] 2 times, k1, BO 2 sts, p1, [k1, p1] 2 times, \*k1, [k1, p1] 2 times, k1, BO 2 sts, p1, [k1, p1] 2 times; rep from \* once.

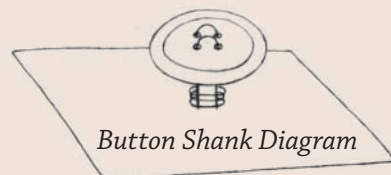

*A Knitting Wrapsody* by Kristin Omdahl  
\$24.95 Paperback + DVD, 136 pages, 8½ × 9,  
ISBN 9781596683075

**Next row:** [K1, p1] 2 times, [(k1, p1) in next st] 2 times, [k1, p1] 2 times, \*k1, [k1, p1] 2 times, [(k1, p1) in next st] 2 times, [k1, p1] 2 times.

**Next row:** Rep Row 5.

**Next row:** Rep Row 1.

Loosely BO 12 sts in patt, draw yarn through st on right-hand needle to fasten off but do not cut yarn, k1, BO next 12 sts in patt, draw yarn through last st on right-hand needle to fasten off but do not cut yarn, k1, BO rem 12 sts in patt and draw yarn through last st and fasten off. Drop rem 2 sts from right needle and ravel to CO edge.

### FINISHING

Sew three sets of two buttons tog (one on RS and one on WS of fabric, opposite buttonholes) 1" (2.5 cm) in from edge and centered in each of the cable panels. Wrap yarn around the base of each button to form a shank as shown at left.

Weave in loose ends. Wet-block and pin to finished measurements. Let air-dry completely before removing pins.

For a larger, luxurious wrap, double the width and length: Cast on 64 stitches (a multiple of 13 stitches plus 12) and knit until the piece is 72" (183 cm) long. But plan for four times as much yarn—880 yards (805 meters)—if you do. ■



**EN POINTE PULLOVER**  
by Alice Tang. **PAGE 26.**  
YARN Louet KidLin Lace  
Weight

uncommon  
*Flax*

*L. usitatissimum*, genus *Linum*,  
family Linaceae



**GATHERED FRONT TANK**  
by Mercedes Tarasovich-Clark.  
**PAGE 32.**  
YARN Maggiknits Maggi's Linen







**HELIOTROPIC PULLOVER**  
by Mercedes Tarasovich-Clark.  
**PAGE 34.**  
YARN Rowan Lenpur Linen,  
distributed by Westminster  
Fibers



**SWIRL CROP JACKET**  
by Andrea Babb. **PAGE 36.**  
YARN Fibra Natura Flax,  
distributed by Universal Yarn



< Assembling two rectangle pieces into a Möbius-like strip centers a dramatic, floating twist at the front of **ALICE TANG'S EN POINTE PULLOVER**. Linen blended with mohair creates an unusual fabric with haloed stitches that ruche and fold without bulk. **PAGE 26.**



**MERCEDES TARASOVICH- > CLARK** knits a semicircle out of loosely plied yarn of cotton and Irish linen to create a gently gathered camisole front with flowing drape. A traditionally shaped back ensures neat, trim fit. **GATHERED FRONT TANK. PAGE 32.**

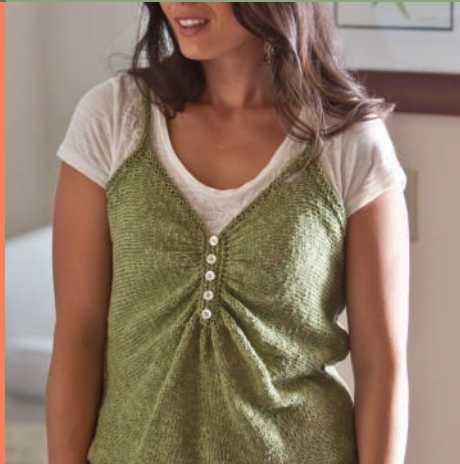

^ Adele Astaire inspired **AMY CHRISTOFFERS'S V-YOKE CARDIGAN**—its swingly simplicity and Deco detailing take full advantage of a slippery, sleek viscose yarn tempered by linen's earthiness. **PAGE 28.**



< The **HELIOTROPIC PULLOVER** spirals delicate texture along the yoke of a simply shaped tee with a generous, fluid silhouette. Slipped stitches pop in soft, silky Lenpur spiked with linen's strength and heavy drape. **MERCEDES TARASOVICH-CLARK. PAGE 34.**



## The Useful Plant

Linen's long bast fibers—spun and dyed for tens of thousands of years—show off crisp, clean drape like no other fiber.

^ **ANDREA BABB'S SWIRL CROP JACKET** exploits pure linen's crisp body by building a sweater out of an architectural curve-shaped ruffle trimmed with welting. Simply shaped back, front pieces, and sleeves frame dramatic folds. **PAGE 36.**



## EN POINTE PULLOVER

Alice Tang

**Finished Size** 32 (36, 40, 44, 50)" bust circumference. Sweater shown measures 36", modeled with 3" of positive ease.

**Yarn** Louet KidLin Lace Weight (49% linen, 35% kid mohair, 16% nylon; 250 yd [229 m]/50 g): #23 deep cerise, 4 (4, 5, 5, 6) skeins.

**Needles** Size 10 (6 mm). Adjust needle size if necessary to obtain the correct gauge.

**Notions** Removable markers (m) or waste yarn; crochet hook in size C/2 (2.75 mm) or D/3 (3.25 mm); tapestry needle.

**Gauge** 16½ sts and 24 rows = 4" in St st.

### NOTES

- The body of the sweater is made of two sideways stockinette rectangles. To check or customize the fit, work the back and front to the lengths indicated, then place the stitches on waste yarn holders. Baste the two pieces together at the shoulders and along the sides below the armhole openings as given in the directions and try the sweater on. If necessary, add or remove rows to achieve the desired fit before completing the garment.
- The sleeves are picked up around the armhole openings and worked back and forth in rows down to the wrist.
- To minimize the number of ends to weave in, work the shoulder seams and back neck finishing in one step as follows: Join the first shoulder seam using slip-stitch crochet (see Glossary), continue by working a row of single crochet (sc; see Glossary) across the back neck edge, and then join the second shoulder seam using slip-stitch crochet.

### BACK

CO 86 (86, 90, 96, 100) sts. Work in St st for 96 (108, 120, 132, 150) rows—piece

measures about 16 (18, 20, 22, 25)" from CO. BO all sts.

### FRONT

CO 86 (86, 90, 96, 100) sts. Work in St st for 156 (168, 180, 192, 210) rows—piece measures about 26 (28, 30, 32, 35)" from CO. BO all sts.

### ASSEMBLE BODY

Block rectangles to measurements. Lay back piece on a flat surface, WS facing up, and with selvedges running across top and bottom. Along upper selvedge, place a marker 5 (5¼, 6½, 7½, 8¾)" in from each end to indicate shoulder seams—6 (6½, 7, 7, 7½)" between markers for back neck. Measure down 8 (8¼, 8¾, 9¼, 9¾)" from upper selvedge along CO and BO edges at each side, and place markers to indicate base of armholes, leaving 12¼ (12½, 13, 14, 14½)" below each armhole marker for side seam. Lay front on top of back, RS facing up, pin front to back along left-front shoulder, and sew left shoulder seam (see Notes for seaming method). Put a Möbius half-twist in front as shown in

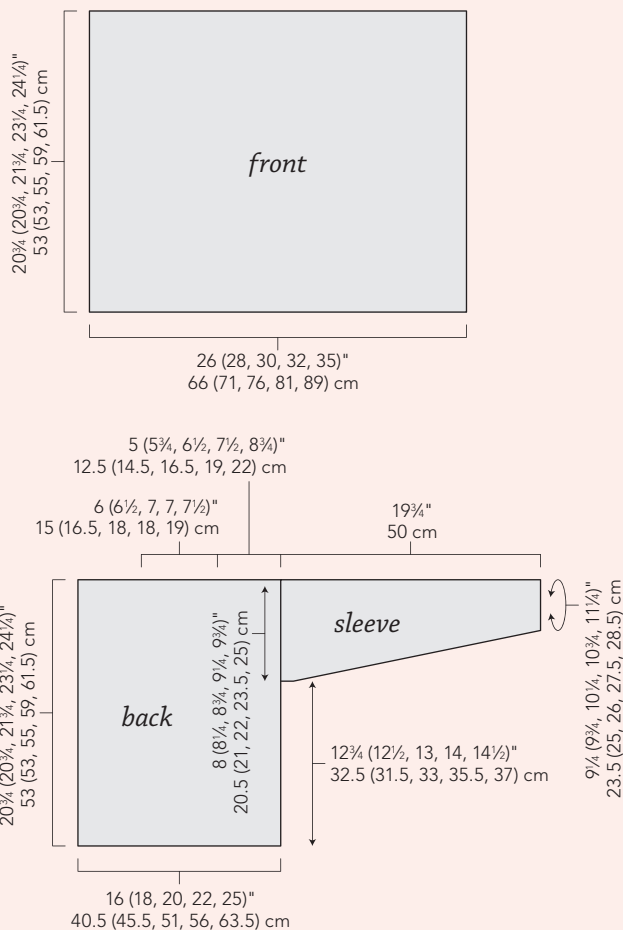

The loose gauge given for this garment helps the stockinette edges lie flat and creates a drapery fabric that flows without bulk. A mohair halo fills in the larger-than-normal stitches.



# Yarn with a colorful past.



Edward W. Brown  
establishes the family farm  
in 1910.



Edward's grandson,  
Harlan Brown.  
He established the  
Brown sheep yarn  
mill on the same farm in 1980.



Brown Sheep Company, Inc.  
MITCHELL, NEBRASKA

## Quality Yarn from Quality People

[www.brownsheep.com](http://www.brownsheep.com)



photo—purl side of right front will now be visible. Sew right shoulder seam. Do not sew side seams yet.

### SLEEVES

With RS facing, pick up and knit 33 (34, 36, 38, 40) sts between armhole marker and shoulder seam, then 33 (34, 36, 38, 40) sts between shoulder seam and other armhole marker—66 (68, 72, 76, 80) sleeve sts. Work in St st for 19 (19, 19, 19, 13) rows, beg and ending with a WS row—piece measures about  $3\frac{3}{4}$  ( $3\frac{3}{4}$ ,  $3\frac{3}{4}$ ,  $3\frac{3}{4}$ ,  $2\frac{3}{4}$ )" from pick-up row. **Dec row:** (RS) K2tog, knit to last 2 sts, k2tog—2 sts dec'd. Rep Dec row every 8th row 7 (7, 3, 0, 0) times, then every 6th row 6 (6, 11, 15, 16) times—38 (40, 42, 44, 46) sts rem. Work even until sleeve measures about  $19\frac{3}{4}$ " (or 118 rows total) from pick-up row. BO all sts.

### FINISHING

Sew sleeve and side seams. Using crochet hook, work sc across back neck selvedge to prevent the neckline from stretching. Weave in ends.

Alice Tang lives in the San Francisco Bay area. She designs both hand and machine knits. See more of her designs on [www.tangramknits.com](http://www.tangramknits.com).



## V-YOKE CARDIGAN

Amy Christoffers

**Finished Size**  $33\frac{1}{2}$  (35 $\frac{1}{2}$ , 38, 40, 43, 45, 47)" bust circumference, buttoned. Cardigan shown measures  $33\frac{1}{2}$ ", modeled with  $\frac{1}{2}$ " positive ease.

**Yarn** Classic Elite Firefly (75% viscose, 25% linen; 155 yd [142 m]/50 g): #7760 Delos, 8 (9, 10, 11, 12, 13, 14) skeins.

**Needles** Size 4 (3.5 mm): 24" circular (cir) and set of double-pointed (dnp). Size 3 (3.25 mm): 2 dnp. Adjust needle

size if necessary to obtain the correct gauge.

**Notions** Markers (m); stitch holders; tapestry needle; five  $\frac{1}{2}$ " buttons.

**Gauge** 24 sts and 28 rows = 4" in St st on larger needles.

### NOTES

- The back and front bodices of this cardigan are worked first, from the lower edges to the shoulders. Work cardigan skirt by picking up stitches along the lower edge of each bodice, casting on the underarm stitches, then working down to the lower edge.

### Stitch Guide

**M1R:** With left needle tip, lift strand between needles from back to front. Knit loop through the front.

**M1L:** With left needle tip, lift strand between needles from front to back. Knit loop through the back.

**M1PR:** With left needle tip, lift strand between needles from back to front. Purl loop through the front.

**M1PL:** With left needle tip, lift strand between needles from front to back. Purl loop through the back.

### BACK BODICE

With larger needle, CO 3 sts. Do not join.

#### Shape bodice:

**Row 1:** (WS) P1, k1, p1.

**Row 2:** (RS) K1, M1R (see Stitch Guide), k1, M1L (see Stitch Guide), k1—5 sts.

**Row 3:** P1, M1PR (see Stitch Guide), p3, M1PL (see Stitch Guide), p1—7 sts.

**Row 4:** K1, M1R, knit to last st, M1L, k1—2 sts inc'd.

**Row 5:** P1, M1PR, purl to last st, M1PL, p1—2 sts inc'd.

Rep last 2 rows 19 (21, 22, 24, 25, 27, 28) more times—87 (95, 99, 107, 111, 119, 123) sts.

**Sizes  $33\frac{1}{2}$  (38, 43, 47)" only:** Rep Row 4

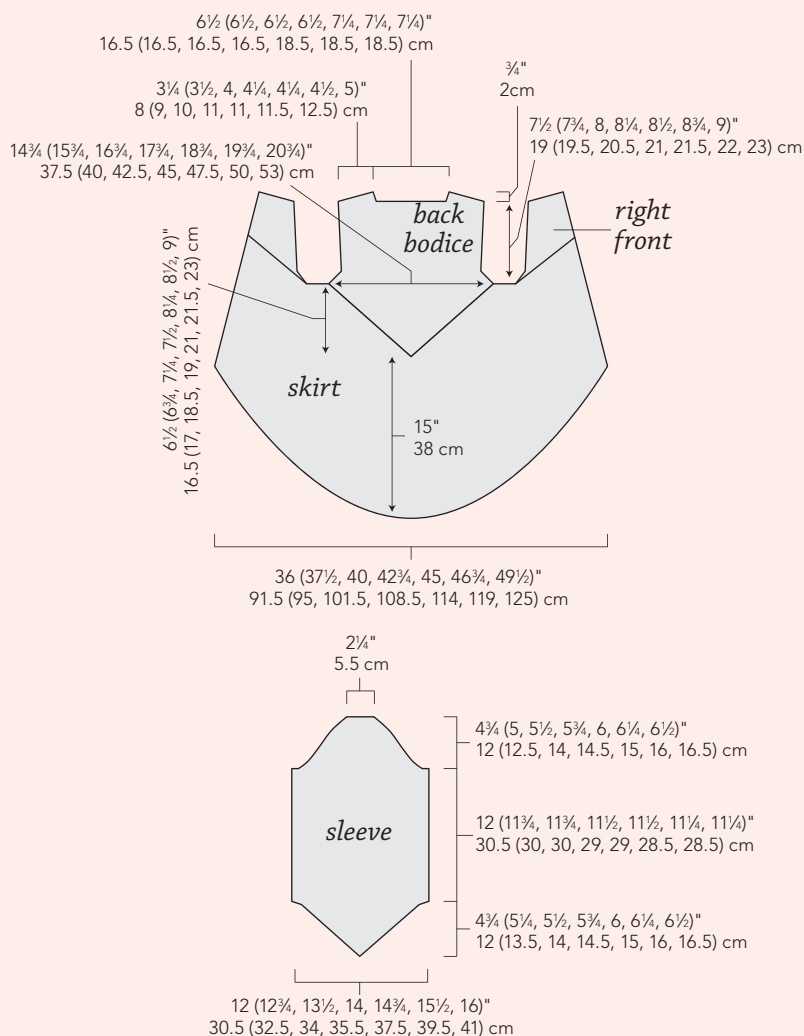



**CASCADE YARNS**  
DISTRIBUTOR OF FINE YARN

# Sierra

80% Pima Cotton  
20% Wool

**Great Stitch Definition**

**Easy Care**

**Year Round Yarn**

Download the pattern  
**FREE**  
at [cascadeyarns.com](http://cascadeyarns.com)



ravelry

once more—89 (101, 113, 125) sts. Work 1 row even.

**All sizes: Shape armholes:** Dec 1 st each edge on next RS row, then every other row 4 (5, 6, 7, 8, 9, 10) times—79 (83, 87, 91, 95, 99, 103) sts rem. Work even until armholes measure  $7\frac{1}{2}$  ( $7\frac{3}{4}$ , 8,  $8\frac{1}{4}$ ,  $8\frac{1}{2}$ ,  $8\frac{3}{4}$ , 9)" from first armhole dec row, ending with a WS row. **Shape neck and shoulders:**

**Next row:** (RS) Work 20 (22, 24, 26, 26, 28, 30) sts, join 2nd ball of yarn and BO center 39 (39, 39, 39, 43, 43, 43) sts for neck, work to end. Shape right shoulder using short-rows (see Glossary) as foll:

**Short-Row 1:** (WS) Purl across left shoulder to neck edge, drop yarn; on right shoulder, p14 (16, 18, 18, 20, 20), wrap next st, turn, knit to end of right shoulder.

**Short-Row 2:** (WS) P6 (8, 10, 10, 10, 10, 10), wrap next st, turn, knit to end.

**Next row:** (WS) Purl to end, hiding wraps. Knit 1 row. Place sts on holder.

**Shape left shoulder:** Pick up yarn at neck edge.

**Short-Row 1:** (RS) K14 (16, 18, 18, 18, 20, 20), wrap next st, turn, purl to end.

**Short-Row 2:** (RS) K6 (8, 10, 10, 10, 10, 10), wrap next st, turn, purl to end.

**Next row:** (RS) Knit to end, hiding wraps. Place sts on holder.

#### RIGHT-FRONT BODICE

With larger needle, CO 3 sts. **Shape bodice and armhole:**

**Row 1:** (WS) P1, k1, p1.

**Row 2:** (RS) K1, M1R, k2—4 sts.

**Row 3:** P3, M1PL, p1—5 sts.

**Row 4:** K1, M1R, knit to last 3 sts, ssk, k1—1 bodice st inc'd, 1 armhole st dec'd (no change in st count).

**Row 5:** Purl to last st, M1PL, p1—1 bodice st inc'd.

Cont to dec 1 st at armhole edge every RS row 4 (5, 6, 7, 8, 9, 10) more times **and at the same time** inc 1 st at bodice edge every row 23 (25, 27, 29, 31, 33, 35) more times—25 (26, 27, 28, 29, 30, 31) sts. Work 1 WS row even. **Shape neck: Dec row:** (RS) K1, k2tog, knit to end—1 st dec'd. Rep Dec row every 4th row 4 (3, 2, 1, 2, 1, 0) more times—20 (22, 24, 26, 26, 28, 30) sts rem. Work even until armhole measures  $7\frac{1}{2}$  ( $7\frac{3}{4}$ , 8,  $8\frac{1}{4}$ ,  $8\frac{1}{2}$ ,  $8\frac{3}{4}$ , 9)" from first armhole dec row, ending with a WS row. **Shape shoulder:**

**Short-Row 1:** (RS) K14 (16, 18, 18, 18, 20, 20), wrap next st, turn, purl to end.

**Short-Row 2:** (RS) K6 (8, 10, 10, 10, 10, 10), wrap next st, turn, purl to end.

**Next row:** (RS) Knit across all sts, hiding

wraps. Purl 1 row. Join sts to right-back shoulder using three-needle BO (see Glossary).

#### LEFT-FRONT BODICE

With larger needle, CO 3 sts. **Shape bodice and armhole:**

**Row 1:** (WS) P1, k1, p1.

**Row 2:** (RS) K2, M1L, k1—4 sts.

**Row 3:** P1, M1PR, p3—5 sts.

**Row 4:** K1, k2tog, knit to last st, M1L, k1—1 bodice st inc'd, 1 armhole st dec'd (no change in st count).

**Row 5:** P1, M1PR, purl to end—1 bodice st inc'd.

Cont to dec 1 st at armhole edge every RS row 4 (5, 6, 7, 8, 9, 10) more times **and at the same time** inc 1 st at bodice edge every row 23 (25, 27, 29, 31, 33, 35) more times—25 (26, 27, 28, 29, 30, 31) sts. Work 1 WS row even. **Shape neck: Dec row:** (RS) Knit to last 3 sts, ssk, k1—1 st dec'd. Rep Dec row every 4th row 4 (3, 2, 1, 2, 1, 0) more time(s)—20 (22, 24, 26, 26, 28, 30) sts rem. Work even until armhole measures  $7\frac{1}{2}$  ( $7\frac{3}{4}$ , 8,  $8\frac{1}{4}$ ,  $8\frac{1}{2}$ ,  $8\frac{3}{4}$ , 9)" from first armhole dec row, ending with a RS row. **Shape shoulder:**

**Short-Row 1:** (WS) P14 (16, 18, 18, 18, 20, 20), wrap next st, turn, knit to end.

**Short-Row 2:** (WS) P6 (8, 10, 10, 10, 10, 10), wrap next st, turn, knit to end.

**Next row:** (WS) Purl across all sts, hiding wraps. Join sts to left-back shoulder using three-needle BO.

#### SKIRT

With RS of each bodice facing, pick up and knit 31 (32, 35, 37, 39, 41, 43) sts across lower edge of left front, use the backward-loop method to CO 12 (12, 14, 14, 16, 16, 16) sts for underarm, pick up and knit 89 (95, 101, 107, 113, 119, 125) sts across lower edge of back, CO 12 (12, 14, 14, 16, 16, 16) sts for underarm, pick up and knit 31 (32, 35, 37, 39, 41, 43) sts across lower edge of right front—175 (183, 199, 209, 223, 233, 243) sts total.

**Row 1:** (WS) Purl.

**Inc row:** (RS) K1, [k2, M1] 12 times, k44 (48, 56, 55, 62, 67, 66), [M1, k2] 9 (9, 9, 12, 12, 12, 15) times, k1, [M1, k2] 9 (9, 9, 12, 12, 12, 15) times, k44 (48, 56, 55, 62, 67, 66), [M1, k2] 12 times, k1—217 (225, 241, 257, 271, 281, 297) sts. Work even in St st until piece measures 15" from underarm CO, ending with a WS row. **I-cord BO:**

Use the invisible provisional method (see Glossary) to CO 3 sts onto left needle, with larger dpn, \*k2, ssk (1 st from I-cord and 1 st from skirt), sl 3 sts back to left needle;



rep from \* across skirt, ending at center right-front edge. **Turn corner:** Work 2 rows of unattached I-cord. Change to smaller dpn and beg working up center-front edge.

**Next row:** K3 (I-cord sts), pick up and knit 1 st along selvedge, slip 4 sts back to left needle. **Applied I-cord: Next row:** K2, ssk, pick up and knit 1 st, slip 4 sts back to left needle. Rep last row 3 more times, not picking up a st on last row. **Make buttonhole:** Work 2 rows unattached I-cord. **Next row:** K3, skipping 3 selvedge rows, pick up and knit 1 st along selvedge, slip 4 sts back to left needle (1 buttonhole completed). Cont working applied I-cord along right-front edge, working buttonhole every 3" 4 more times. Cont working applied I-cord around the back neck and down left front. Work corner as for right front (2 rows unattached I-cord), then graft live sts to provisional CO using Kitchener st (see Glossary).

#### SLEEVES

With dpn, CO 3 sts. **Next row:** (WS) P1, k1, p1. **Inc row:** (RS) K1, M1R, k1, M1L, k1—5 sts. **Inc row:** (WS) P1, M1PR, p3, M1PL, p1—7 sts. Cont to inc 1 st each side every row 31 (33, 35, 37, 39, 41, 43) more times, ending with a RS row—69 (73, 77, 81, 85, 89, 93) sts. Do not turn. **Joining row:** Use the backward-loop method to CO 2 sts at end of row, place marker for beg of rnd, CO 2 sts, join in the rnd—73 (77, 81, 85, 89, 93, 97) sts. Work even in St st (knit every rnd) until sleeve measures 12 ( $11\frac{3}{4}$ ,  $11\frac{1}{2}$ ,  $11\frac{1}{2}$ ,  $11\frac{1}{2}$ ,  $11\frac{1}{4}$ )" from Joining row, ending 6 (6, 7, 7, 8, 8, 8) sts before end of rnd. **Shape cap:**





## Authorized Louet North America Retailers

### ALASKA

**Fiber N Ice**  
PO Box 521215  
4038 Casey Dr.  
Big Lake, AK, 99652  
(907) 892-8901  
dlmspinner@yahoo.com  
www.fibericealaska.com

### CALIFORNIA

**Purlescence Yarns**  
586 S. Murphy Ave.  
Sunnyvale, CA, 94086  
(408) 735-9276 (ph)  
(408) 735-9279 (fx)  
info@purlescencyarns.com  
www.purlescencyarns.com

### Yarns on First

1305 First St  
Napa, CA, 94559  
(707) 257-1363  
cligouri@gmail.com

### COLORADO

**Colorado Fiber Arts**  
121 Broadway Ave  
Pueblo, CO, 81004  
(719) 543-1161 (ph)  
(719) 543-1890 (fx)  
karen@coloradofiberarts.com  
www.coloradofiberarts.com

### CONNECTICUT

**Woolworks Ltd.**  
154 Main St.  
Putnam, CT, 06260  
(860) 963-1228  
woolworks@snet.net  
www.woolworksltd.com

### FLORIDA

**Hanks Yarn and Fiber Shop**  
4127 NW 16th Blvd  
Gainesville, FL, 32605  
(352) 338-7222  
hanksyam@gmail.com  
www.hanksyam.com

### GEORGIA

**Creative Yarns**  
134 Speer Ave  
Macon, GA, 31204  
(478) 746-5648  
clo@creativeyarns.net  
www.creativeyarns.net

### Knitch

1052 St Charles Ave.  
Atlanta, GA, 30306  
(404) 745-9276 (ph)  
(404) 249-6192 (fx)  
kim@knitchknitting.com  
www.knitchknitting.com

### KENTUCKY

**The Woolery**  
239 West Main St.  
Frankfort, KY, 40601  
(502) 352-9800 (ph)  
(502) 352-9802 (fax)  
nancy@woolery.com  
www.woolery.com

### MASSACHUSETTS

**Black Purls Yarn Shop**  
685 RT 6A  
East Sandwich, MA, 02537  
(508) 362-8880  
BlackPurlsYarn@yahoo.com  
www.blackpurlsyarn.com

### MICHIGAN

**Thistledown Shoppe LLC**  
P.O. Box 52  
419 N. St., Joseph St.  
Suttons Bay, MI, 49682  
(231) 271-9276  
thistledownshoppe@  
yahoo.com

### NEW JERSEY

**Yarn Bazaar**  
4 Victoria Place  
West Windsor, NJ, 08550-5418  
(877) 275-0475 (toll free ph)  
(609) 897-9590 (fx)  
joellen@yarnbazaar.com  
www.yarnbazaar.com

### NEW YORK

**The Spinning Room**  
190 Main Street  
Altamont, NY, 12009  
(518) 861-0038  
info@spinningroom.net  
www.spinningroom.net

### NORTH DAKOTA

**cedesigns and Yarn Shoppe**  
417 East Broadway  
Bismarck, ND, 58501  
(701) 471-2131  
cedesigns@midconetwork.com

### OHIO

**BlackLocust Farm LLC**  
13225 New London Eastern  
Spencer, OH, 44275  
(330) 648-2720  
blacklocustwool@msn.com

### OREGON

**Knot Another Hat**  
16 Oak St. #202  
Hood River, OR, 97031  
(541) 308-10002  
sarah@knotanotherhat.com  
www.knotanotherhat.com

### The Websters Inc.

11 North Main Street  
Ashland, OR, 97520  
(541) 482-9801  
websters@mind.net

### PENNSYLVANIA

**Lucy Sweetland**  
8 Kennedy Drive  
Downingtown, PA, 19335  
(610) 269-2519  
alissshop@gmail.com

### Glory-ous Knits

15 Harris Circle  
Watsonstown, PA, 17777  
(570) 437-4139 (ph)  
(570) 437-4139 (fx)  
customerservice@  
glory-ousknits.com  
www.glory-ousknits.com

### UTAH

**Blazing Needles**  
1365 S 1100 E  
Salt Lake City, UT, 84105  
(801) 487-5648  
cynthia@blazing-needles.com  
www.blazing-needles.com

### WASHINGTON

**Sheep's Clothing**  
8551 Gage Blvd, Ste H  
Kennewick, WA, 99336  
(509) 734-2484

### WISCONSIN

**Cat and Crow LLC**  
205 E Main Street  
Mt Horeb, WI, 53572  
(608) 437-1771  
thecatandcrow@mhtc.net

### CANADA

#### ALBERTA

**Make One Yarn Studio**  
841 1st Ave N.E.  
Calgary, AB, T2E 0C2  
(403) 802-4770  
info@make1yarns.ca  
www.make1yarns.com

#### BRITISH COLUMBIA

**Art of Yarn**  
3003 Pandosy Street  
Kelowna, BC, V1Y 1W3  
(250) 717-3247 (ph)  
(250) 762-5998 (fx)  
info@artofyarn.com  
www.artofyarn.com

#### Fun Knits Yarn Shop

Unit 2B 671 Plaza Rd  
Quadra Island, BC, V0P-1N0  
(250) 285-2751  
shelmack@telus.net  
www.funknits.com

#### ONTARIO

**Wool N' THINGS**  
1439 Youville Dr, Unit 20  
Orleans (Ottawa), ON, K1C4M8  
(613) 841-8689  
gisele@woolnthings.com  
www.woolnthings.com

#### QUEBEC

**Mandragore**  
47 Compton E  
Waterville, QC, J0B3H0  
(819) 575-8241  
mandrago@abacom.com  
www.lemandragore.com

Pattern: Ribs on Diagonal  
Yarn: GEMS Merino, Light Worsted Weight  
Color: #63 Candy Apple Red  
Designer: Melissa Leapman

Visit us online at [www.louet.com](http://www.louet.com) to download this and many other patterns, or locate an authorized retailer near you on this page or on our website under "Find a Store".



north america  
make it your own™

BO 12 (12, 14, 14, 16, 16, 16) sts, work to end—61 (65, 67, 71, 73, 77, 81) sts rem. Working back and forth in rows, dec 1 st each edge every RS row 15 (16, 18, 18, 19, 19, 19) times, then every row 8 (9, 8, 10, 10, 12, 14) times—15 sts rem. BO all sts.

### FINISHING

Block pieces to measurements. Sew sleeves into armholes. **Sleeve edging:** Using larger dpn and provisional method, CO 3 sts. Work applied I-cord around lower edge of sleeve, beg at center of Joining row CO sts. Graft sts from CO to 3 live sts. Weave in ends. Sew buttons to left front corresponding to buttonholes on right front. Block again, if desired.

*Amy Christoffers* lives in Vermont with her husband, son, and a cat. More information about her knitting can be found at [www.savoryknitting.com](http://www.savoryknitting.com).



## GATHERED FRONT TANK

Mercedes Tarasovich-Clark

**Finished Size** 35 (39, 43, 47, 51)" bust circumference. Garment shown measures 35", modeled with 2" of positive ease.

**Yarn** Maggiknits Maggi's Linen (52% cotton, 48% linen; 126 yd [115 m]/50 g): #24 pistachio green, 4 (5, 6, 7, 8) balls.

**Needles** Body—size 7 (4.5 mm): 24" circular (cir). Trim—size 4 (3.5 mm): 24" cir. Adjust needle size if necessary to obtain the correct gauge.

**Notions** Markers (m); tapestry needle; safety pins; five ½" buttons; sewing needle and matching thread.

**Gauge** 18 sts and 24 rows = 4" in St st on larger needles.

### NOTES

- Camisole front is knit in an unusual shape, and then seamed along trim edges along front gathered edge at

center bust. Bottom hem of front is shaped with short-rows to square up the corners.

### FRONT

With larger cir needle, CO 40 (44, 48, 52, 56) sts. **Inc row:** (RS) \*K1, M1; rep from \* to last st, k1—79 (87, 95, 103, 111) sts. Work 3 rows even in St st. **Inc row:** (RS) \*K2, M1; rep from \* to last st, k1—118 (130, 142, 154, 166) sts. Place marker 42 (46, 50, 55, 59) sts in from each edge—34 (38, 42, 44, 48) center sts. **Note:** Edge shaping and center shaping occur at the same time. Read through foll sections before proceeding. Work 6 rows even in St st, ending with a RS row. Then inc 1 st each edge every RS row 9 (10, 11, 12, 13) times, mark each edge with safety pin, then dec 1 st each edge every RS row 11 (12, 13, 14, 15) times. **At the same time,** inc 10 (9, 10, 11, 9) sts evenly between m every 4th row 5 (6, 6, 6, 8) times—84 (92, 102, 110, 120) sts between m; 40 (44, 48, 53, 57) sts each side. Work 7 (9, 11, 13, 15) rows even, ending with a WS row. **Next row:** (RS) BO 40 (44, 48, 53, 57) sts, removing m, work to end, removing m—124 (136, 150, 163, 177) sts rem. **Next row:** (WS) BO 40 (44, 48, 53, 57) sts—84 (92, 102, 110, 120) sts rem; cont across rem sts, working short-rows (see Glossary) as foll: P24 more sts (25 sts total on right needle), wrap next st, turn. **Shape first corner:** **Row 1:** (RS) Knit to last 2 sts, k2tog, turn—1 st dec'd. **Row 2:** (WS) Purl to 1 st before last wrapped st, wrap next st, turn. Rep last 2 rows until last row worked is: (RS) K1, k2tog, turn. **Next row:** (WS)

Purl to end, working wraps tog with wrapped sts. **Shape second corner:** **Row 1:** (RS) Ssk, k23, wrap next st, turn—1 st dec'd.

**Row 2:** (WS) Purl to end.

**Row 3:** (RS) Ssk, knit to 1 st before last wrapped st, wrap next st, turn. Rep last 2 rows until last row worked is: (WS) P2, turn. **Next row:** (RS) Knit to end, working wraps tog with wrapped sts—60 (68, 78, 86, 96) sts rem. Change to smaller cir needle and knit 4 rows. BO all sts.

### BACK

With smaller cir needle, CO 88 (96, 106, 114, 124) sts. Knit 4 rows. Change to larger cir needle and work in St st until piece measures 4 (4½, 5, 5½, 6)" from CO, ending with a WS row. **Shape sides:** Dec 1 st each edge every 12th row 5 (4, 5, 4, 5) times—78 (88, 96, 106, 114) sts rem. Work even until piece measures 13¾ (14¾, 15¾, 16¾, 17¾)" from CO, ending with a WS row. **Shape armholes:** BO 7 (8, 9, 10, 11) sts at beg of next 2 rows. Dec 1 st each edge every RS row 6 (8, 9, 10, 11) times—52 (56, 60, 66, 70) sts rem. Cont in patt until armholes measure 5½ (6, 6½, 7, 7½)" ending with a WS row. Change to smaller needle and knit 4 rows. BO all sts.

### FINISHING

**Front edging:** With RS facing and smaller cir needle, pick up and knit 4 sts for every 1" along front, between safety pins and along CO edge. Knit 3 rows, ending with a WS row. BO all sts. **Straps:** With RS facing and smaller cir needle,

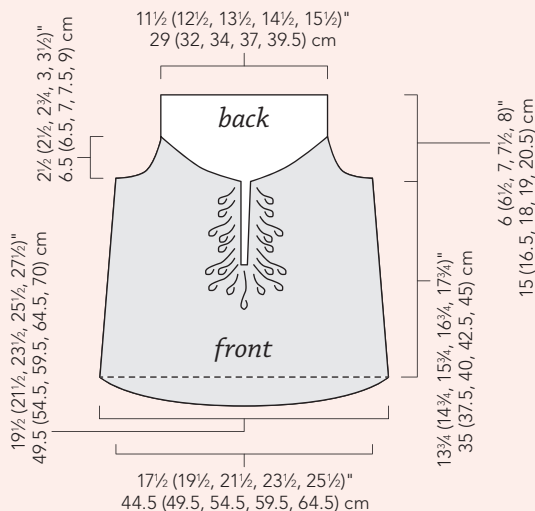

LOVE THE **COLOR**  
LOVE THE YARN

INTRODUCING MALABRIGO BOOK 3,  
RASTA NECKWARMER, COLOR 862 PIEDRAS.

**malabrigo**



[www.MalabrigoYarn.com](http://www.MalabrigoYarn.com)

beg at underarm, pick up and knit 4 sts for every 1" up right back armhole edge, CO 26 (28, 30, 32, 34) sts for strap, pick up and knit 4 sts for every 1" along right front armhole edge to underarm. Knit 3 rows, ending with a WS row. BO all sts. Rep along left-front and left-back armhole edges. Sew side seams. Seam front gathered edge. Sew 5 buttons in place along front gathers, one  $\frac{1}{2}$ " in from both top and bottom of faux placket, with others spaced evenly between. Weave in all ends and block to shape.

*Mercedes Tarasovich-Clark* owns her own dyeing company, Kitchen Sink Dyeworks. She lives in the land of kudzu (Alabama) with her husband, three dogs, and two cats.



## HELIOTROPIC PULLOVER

Mercedes Tarasovich-Clark

**Finished Size** 45 $\frac{1}{4}$  (49 $\frac{1}{4}$ , 54, 59 $\frac{1}{2}$ , 65 $\frac{3}{4}$ )" bust circumference. Sweater shown measures 45 $\frac{1}{4}$ ", modeled with several inches of positive ease.

**Yarn** Rowan Lenpur Linen (75% Vilenpur viscose, 25% linen; 126 yd [115 m]/50 g): #561 saffron, 7 (7, 9, 10, 11) balls. Yarn distributed by Westminster Fibers.

**Needles** Ribbing and yoke—size 4 (3.5 mm): 24" circular (cir) and set of double-pointed (dnp). Body—size 6 (4 mm): 24" cir. Adjust needle size if necessary to obtain the correct gauge.

**Notions** Markers (m); cable needle (cn); stitch holders; tapestry needle.

**Gauge** 18 sts and 24 rnds = 4" in St st on larger needle; 22 sts and 32 rnds = 4" in yoke patt st on smaller needle.

### NOTES

- Top is worked in the round from the top down.
- Slip stitches purlwise with yarn in back.

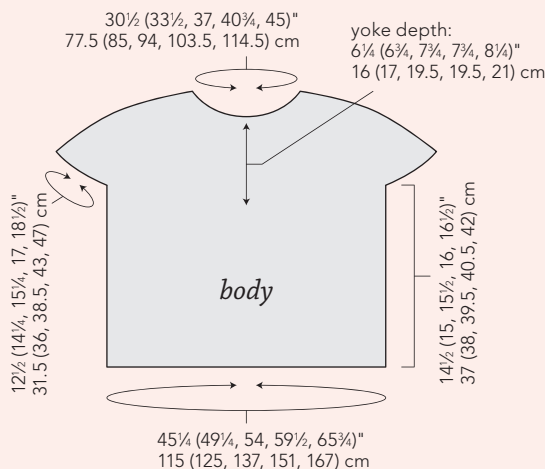

### Stitch Guide

**1×3 Twisted Rib:** (multiple of 4 sts)

**Rnd 1:** \*K1 through back loop (tbl), p3; rep from \* to end.  
Rep Rnd 1 for patt.

**1/1 LSC:** Sl 1 st onto cn and hold in front, k1, sl st from cn to right needle (without knitting).

### YOKE

With smaller cir needle, CO 168 (184, 204, 224, 248) sts. Place marker (pm) and join in the rnd. Work in 1×3 twisted rib (see Stitch Guide) for  $\frac{1}{2}$ ".

**Rnd 1:** \*1/1 LSC (see Stitch Guide), k2; rep from \* to end.

**Rnd 2:** \*K1, sl 1, k2; rep from \* to end.

**Rnd 3:** \*K1, 1/1 LSC, k1; rep from \* to end.

**Rnd 4:** Knit.

**Rnd 5:** \*K2, 1/1 LSC; rep from \* to end.

**Rnd 6:** \*K3, sl 1; rep from \* to last 4 sts, k3, work 1/1 LSC over last st of rnd and first st of next rnd (keeping beg-of-rnd m in place).

**Rnd 7:** \*K2, 1/1 LSC; rep from \* to last 3 sts, k3.

**Rnd 8:** Knit.

**Rnds 9–16:** Rep Rnds 1–8 once more.

**Rnd 17:** \*M1, 1/1 LSC, k2; rep from \* to end—210 (230, 255, 280, 310) sts.

**Rnd 18:** \*K2, sl 1, k2; rep from \* to end.

**Rnd 19:** \*K2, 1/1 LSC, k1; rep from \* to end.

**Rnd 20:** Knit.

**Rnd 21:** \*K3, 1/1 LSC; rep from \* to end.

**Rnd 22:** \*K4, sl 1; rep from \* to last 5 sts, k4, work 1/1 LSC over last st of rnd and first st of next rnd.

**Rnd 23:** \*K3, 1/1 LSC; rep from \* to last

4 sts, k4.

**Rnd 24:** Knit.

**Rnd 25:** \*1/1 LSC, k3; rep from \* to end.

**Rnd 26:** \*K1, sl 1, k3; rep from \* to end.

**Rnd 27:** \*K1, 1/1 LSC, k2; rep from \* to end.

**Rnd 28:** Knit.

**Rnd 29:** \*K2, 1/1 LSC, k1; rep from \* to end.

**Rnd 30:** \*K3, sl 1, k1; rep from \* to end.

**Rnd 31:** \*K3, M1, 1/1 LSC; rep from \* to end—252 (276, 306, 336, 372) sts.

**Rnd 32:** Knit.

**Rnd 33:** K5, \*1/1 LSC, k4; rep from \* to last st, work 1/1 LSC over last st of rnd and first st of next rnd.

**Rnd 34:** K5, \*sl 1, k5; rep from \* to end.

**Rnd 35:** \*1/1 LSC, k4; rep from \* to end.



# Knitters Have Options

Get the best value for your dollar. Create your perfect needles by choosing from 100's of combinations of our interchangeable Options tips and cables.



## Try Knit Picks Needles

Our cleverly designed interchangeable needles come in three different materials—slick Nickel, gorgeous Harmony wood and affordable Zephyr acrylic. No matter which you choose you can count on smooth joins, sharp tips and flexible cables.

Buy Knit Picks cables and tips individually starting at \$3.99 for tips and \$4.99/ pair of cables or save up to 33% by buying an interchangeable set.

*Knit Picks*® needles are now available in select local yarn stores.

Visit [KnitPicks.com/lys](http://KnitPicks.com/lys) to find a store near you that carries Knit Picks needles.

The color purple and Knitting in Waves of Color with Harmony™ are trademarks of Crafts Americana Group Inc.

SMOOTH JOINS



SHARP TIPS



FLEXIBLE CABLES



Shop online at [KnitPicks.com](http://KnitPicks.com)

*Knit Picks*®

**Rnd 36:** Knit.

**Rnd 37:** \*K1, 1/1 LSC, k3; rep from \* to end.

**Rnd 38:** \*K2, sl 1, k3; rep from \* to end.

**Rnd 39:** \*K2, 1/1 LSC, k2; rep from \* to end.

**Rnd 40:** Knit.

**Rnd 41:** \*K3, 1/1 LSC, k1; rep from \* to end.

**Rnd 42:** \*K4, sl 1, k1; rep from \* to end.

**Rnd 43:** \*K4, 1/1 LSC; rep from \* to end.

**Rnd 44:** Knit.

**Size 45¼" only:**

Rep Rnds 33–35 once.

**Size 49¼" only:**

Rep Rnds 33–39 once.

**Sizes 54 (59½)" only:**

Rep Rnds 33–44 once and then Rnds 33–35 once more.

**Size 65¾" only:**

Rep Rnds 33–44 once and then Rnds 33–39 once more.

**All sizes:**

**Divide body and sleeves:** \*K52 (58, 64, 70, 78) and place these sts on holder for sleeve, k74 (80, 89, 98, 108); rep from \* once more. With larger cir needle and working in St st, use the backward-loop method to CO 16 (18, 18, 20, 22) sts for right underarm, knit and inc 24 (26, 29, 32, 36) sts evenly spaced across front, CO 16 (18, 18, 20, 22) sts for left underarm, knit to end—204 (222, 243, 268, 296) sts. **Body:** Work in St st until piece measures 14 (14½, 15, 15½, 16)" from underarm, inc 0 (2, 1, 0, 0) st(s) on last rnd—204 (224, 244, 268, 296) sts. With smaller cir needle, work in 1×3 twisted rib for ½". BO all sts.

## SLEEVES

Place 52 (58, 64, 70, 78) held sleeve sts onto dpn. With RS facing, pick up and knit 17 (20, 20, 23, 24) sts along underarm, pm, and join in the rnd—69 (78, 84, 93, 102) sts. **Next rnd:** P1 (0, 1, 1, 0), \*k1tbl, p2; rep from \* to last 2 (3, 2, 2, 3) sts, k1tbl, p1 (2, 1, 1, 2). Rep last rnd for ½". BO all sts.

## FINISHING

Weave in ends. Block lightly.

*Mercedes Tarasovich-Clark* owns her own dyeing company, Kitchen Sink Dyeworks. She lives in the land of kudzu (Alabama) with her husband, three dogs, and two cats.



## SWIRL CROP JACKET

Andrea Babb

**Finished Size** 36 (38, 40, 44½, 48)" bust circumference. Sweater shown measures 36", modeled with 3" ease.

**Yarn** Fibra Natura Flax (100% linen; 137 yd [125 m]/50 g): #06 raspberry, 10 (10, 11, 11, 12) skeins. Yarn distributed by Universal Yarn.

**Needles** Size 3 (3.25 mm): 40" circular (cir). Adjust needle size if necessary to obtain the correct gauge.

**Notions** Markers (m); removable markers; stitch holders; tapestry needle.

**Gauge** 24 sts and 32 rows = 4" in St st.

## NOTES

- The ruffle is worked in one piece and encircles the entire front and back. The back and fronts are worked up from the ruffle. Three corded edges are created on the ruffle by folding the knitting and working into the stitches of a previous row.
- The 5" body ruffle is not included in the schematic measurements.

## Stitch Guide

**Corded edge:** The corded edge creates a pin tuck effect in the knitting. With WS tog, fold up the bottom rows of knitting to bring the edge you need to knit into up to the level of the sts on the needle. With right needle, \*place 1 st from WS of specified row onto left needle and p2tog; rep from \* for each st. To avoid missing a st, use markers to count off 10 or 20 sts on each edge and work those sts, then move markers forward and work next group, and so on.

## RUFFLE

Measure about 15 (15, 15, 16, 16) yds of yarn to use as CO tail. Using the long-tail method (see Glossary), CO 700 (716, 730, 758, 782) sts. Do not join. Beg and ending with a purl row, work 9 rows in St st. **First corded edge:** (RS) Work corded edge (see Stitch Guide), working into sts of CO.

Purl 2 rows. Knit 3 rows. Work 8 rows in St st, ending with a WS row.

**Ruffle Dec Row 1:** (RS) K30, [k2tog, k4] 46 times, k2tog, k84 (100, 114, 142, 166), [k2tog, k4] 46 times, k2tog, k30—606 (622, 636, 664, 688) sts rem.

Knit 1 WS row and mark end of this row with removable m. Work 8 rows in St st, ending with a WS row. **2nd corded edge:** Working into sts from marked row (purl ridge above ruffle dec row), work corded edge. Purl 5 rows. Work 6 rows in St st. **Shape neck:** BO 20 sts at beg of next 2 rows for back neck—566 (582, 596, 624, 648) sts rem.

**Ruffle Dec Row 2:** (RS) BO 6 sts (1 st on right needle), [k2tog, k1] 49 times, k2tog, k254 (270, 284, 312, 336), [k2tog, k1] 49 times, k2tog, k7—460 (476, 490, 518, 542) sts rem.

**Next row:** (WS) BO 6 sts, knit to end; mark end of this row with removable m—454 (470, 484, 512, 536) sts rem.

Work 8 rows in St st. **3rd corded edge:** (RS) Working into sts from last marked

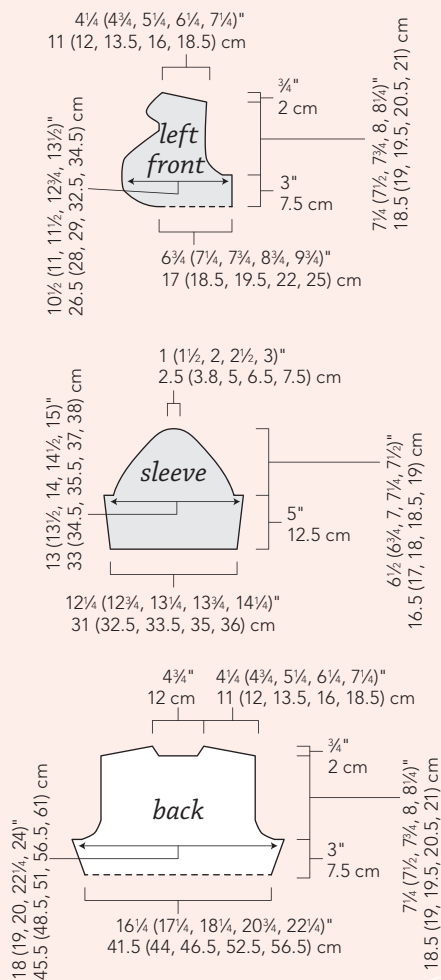



Visit our site for details & class schedules!



# KNIT NATION



## 15- 16 -17 July 2011

London UK's smash hit summer knitting  
& spinning expo brought to you  
by Socktopus & Cookie A

and sponsored by **Knitting**



[www.knitnation.co.uk](http://www.knitnation.co.uk)



row (purl ridge above 2nd ruffle dec row), work corded edge. **Next row:** (WS) BO 7 sts, purl to end—447 (463, 477, 505, 529) sts rem. **Next row:** (RS) BO 7 sts, purl to end—440 (456, 470, 498, 522) sts rem.

**Next row:** (WS) P2tog, purl to last 2 sts, p2tog—438 (454, 468, 496, 520) sts rem.

**Next row:** (RS) K2tog, knit to last 2 sts, k2tog—436 (452, 466, 494, 518) sts rem.

**Next row:** (WS) P2tog, purl to last 2 sts, p2tog—434 (450, 464, 492, 516) sts rem.

**Ruffle Dec Row 3:** (RS) [K2tog, k2] 7 (18, 25, 35, 45) times, [k2tog, k1] 46 (33, 25, 14, 3) times, k2tog, k98 (104, 110, 124, 134), [k2tog, k1] 46 (33, 25, 14, 3) times, [k2tog, k2] 7 (18, 25, 35, 45) times, k2tog—326 (346, 362, 392, 418) sts rem. Break yarn. With WS facing and beg after 20 BO sts at back neck, pick up and purl 14 sts evenly spaced along shaped edge to needle, k326 (346, 362, 392, 418), pick up and purl 14 sts evenly spaced along shaped edge to beg of 20 BO sts at back neck—354 (374, 390, 420, 446) sts total. **Divide for fronts and back:** (RS) P128 (135, 140, 148, 156) and place these sts on a holder for right front, p98 (104, 110, 124, 134) for back, place next 128 (135, 140, 148, 156) sts on a holder for left front.

## BACK

**Inc row:** (WS) P21, purl lifted inc, right slant (RSPI; see Glossary), purl to last 21 sts, purl lifted inc, left slant (LSPI; see Glossary), purl to end—2 sts inc'd. Cont in St st, rep Inc row every WS row 4 more times—108 (114, 120, 134, 144) sts. Work even until piece measures 3" from last purl ridge, ending with a WS row. **Shape armholes:** BO 4 sts at beg of next 6 rows—84 (90, 96, 110, 120) sts rem. Dec 1 st each edge every RS row 2 times—80 (86, 92, 106, 116) sts rem. Work 3 rows even. Dec 1 st each edge on next RS row—78 (84, 90, 104, 114) sts rem. Work 45 (47, 49, 51, 53) rows even, ending with a WS row—armholes should measure about  $7\frac{1}{4}$  ( $7\frac{1}{2}$ ,  $7\frac{3}{4}$ , 8,  $8\frac{1}{4}$ )" from first BO row. **Shape shoulders and neck:** Mark center 20 sts. **Next row:** (RS) BO 8 (9, 10, 12, 14) sts, knit to 2 sts before marked sts, k2tog, join new strand of yarn and BO 20 marked sts, ssk, knit to end—20 (22, 24, 29, 32) sts rem for right shoulder, 28 (31, 34, 41, 46) sts rem for left shoulder. Work both sides separately at the same time. **Next row:** (WS) BO 8 (9, 10, 12, 14) sts, purl to last 2 sts of left shoulder, ssp; on right shoulder, p2tog, purl to end—19 (21, 23, 28, 31) sts rem for each shoulder.

**Next row:** (RS) BO 8 (9, 10, 12, 14) sts, knit

to last 2 sts of right shoulder, k2tog; on left shoulder, ssk, knit to end—10 (11, 12, 15, 16) sts rem for right shoulder, 18 (20, 22, 27, 30) sts rem for left shoulder. **Next row:** (WS) BO 8 (9, 10, 12, 14) sts, purl to last 2 sts of left shoulder, ssp; on right shoulder, p2tog, purl to end—9 (10, 11, 14, 15) sts rem for each shoulder. **Next row:** (RS) BO rem 9 (10, 11, 14, 15) sts of right shoulder; on left shoulder, knit to end. BO rem 9 (10, 11, 14, 15) sts.

## LEFT FRONT

Transfer 128 (135, 140, 148, 156) left-front sts from holder to needle. With WS facing, BO 88 (92, 94, 95, 98) sts (selvedge edge of ruffle will become center-back neck seam, knit to end—40 (43, 46, 53, 58) sts rem.

**Row 1:** (RS) Knit.

**Row 2:** Purl.

**Row 3:** Knit to end, then use the backward-loop method to CO 6 sts at end of row—46 (49, 52, 59, 64) sts.

**Rows 4, 6, 8, 10, 12, and 14:** Purl.

**Row 5:** Knit to end, then CO 5 sts at end of row—51 (54, 57, 64, 69) sts.

**Row 7:** Knit to end, then CO 4 sts at end of row—55 (58, 61, 68, 73) sts.

**Row 9:** Knit to end, then CO 3 sts at end of row—58 (61, 64, 71, 76) sts.

**Row 11:** Knit to end, then CO 2 sts at end of row—60 (63, 66, 73, 78) sts.

**Row 13:** Knit to end, then CO 2 sts at end of row—62 (65, 68, 75, 80) sts.

**Row 15:** Knit to end, then CO 1 st at end of row—63 (66, 69, 76, 81) sts.

Work even until piece measures 3" from last purl ridge, ending with a WS row.

**Shape armhole:** BO 4 sts at beg of every RS row 3 times—51 (54, 57, 64, 69) sts rem. BO 1 st at beg of every RS row 2

times—49 (52, 55, 62, 67) sts rem. Work 3 rows even. BO 1 st at beg of next RS

row—48 (51, 54, 61, 66) sts rem. **Shape**

**neck:** BO 1 st at beg of every WS row 3 times—45 (48, 51, 58, 63) sts rem. BO

2 sts at beg of every WS row 4 times—37 (40, 43, 50, 55) sts rem. At beg of WS

rows, BO 1 st once, then 2 sts once,

then 3 sts once—31 (34, 37, 44, 49) sts rem. BO 2 sts at beg of every WS row 2

times—27 (30, 33, 40, 45) sts rem. Work 4 (6, 8, 10, 12) rows even, ending with a

WS row. **Shape collar:** CO 1 st at end of next RS row—28 (31, 34, 41, 46) sts. CO

2 sts at end of every RS row 2 times—32 (35, 38, 45, 50) sts. CO 3 sts at end of next

RS row—35 (38, 41, 48, 53) sts. Work 4 rows even. At beg of WS rows, BO 1 st

once, then 2 sts once, then 3 sts once, then 1 st once—28 (31, 34, 41, 46) sts rem. **Shape shoulder and neck:** (RS) BO 8 (9, 10, 12, 14) sts, knit to end—20 (22, 24, 29, 32) sts rem. **Next row:** (WS) BO 2 sts, purl to end—18 (20, 22, 27, 30) sts rem. **Next row:** (RS) BO 8 (9, 10, 12, 14) sts, knit to end—10 (11, 12, 15, 16) sts rem. **Next row:** (WS) BO 1 st, purl to end—9 (10, 11, 14, 15) sts rem. BO all sts.

## RIGHT FRONT

Transfer 128 (135, 140, 148, 156) right-front sts from holder to needle. With RS facing and beg at back neck edge, BO 88 (92, 94, 95, 98) sts, knit to end—40 (43, 46, 53, 58) sts rem.

**Row 2:** (WS) Purl to end, then use the backward-loop method to CO 6 sts at end of row—46 (49, 52, 59, 64) sts.

**Rows 3, 5, 7, 9, 11, and 13:** Knit.

**Row 4:** Purl to end, then CO 5 sts at end of row—51 (54, 57, 64, 69) sts.

**Row 6:** Purl to end, then CO 4 sts at end of row—55 (58, 61, 68, 73) sts.

**Row 8:** Purl to end, then CO 3 sts at end of row—58 (61, 64, 71, 76) sts.

**Row 10:** Purl to end, then CO 2 sts at end of row—60 (63, 66, 73, 78) sts.

**Row 12:** Purl to end, then CO 2 sts at end of row—62 (65, 68, 75, 80) sts.

**Row 14:** Purl to end, then CO 1 st at end of row—63 (66, 69, 76, 81) sts.

Work even until piece measures 3" from last purl ridge, ending with a RS row.

**Shape armhole:** BO 4 sts at beg of every WS row 3 times—51 (54, 57, 64, 69) sts rem. BO 1 st at beg of every WS row 2

times—49 (52, 55, 62, 67) sts rem. Work 3 rows even. BO 1 st at beg of next WS

row—48 (51, 54, 61, 66) sts rem. **Shape**

**neck:** BO 1 st at beg of every RS row 3 times—45 (48, 51, 58, 63) sts rem. BO

2 sts at beg of every RS row 4 times—37 (40, 43, 50, 55) sts rem. At beg of RS rows,

BO 1 st once, then 2 sts once, then 3 sts once—31 (34, 37, 44, 49) sts rem. BO

2 sts at beg of every RS row 2 times—27 (30, 33, 40, 45) sts rem. Work 4 (6, 8,

10, 12) rows even, ending with a RS row.

**Shape collar:** CO 1 st at end of next WS row—28 (31, 34, 41, 46) sts. CO 2 sts at

end of every WS row 2 times—32 (35, 38, 45, 50) sts. CO 3 sts at end of next WS

row—35 (38, 41, 48, 53) sts. Work 4 rows even. At beg of RS rows, BO 1 st once,

then 2 sts once, then 3 sts once, then 1 st once—28 (31, 34, 41, 46) sts rem. **Shape**

**shoulder and neck:** (WS) BO 8 (9, 10, 12, 14) sts, purl to end—20 (22, 24, 29,



32) sts rem. **Next row:** (RS) BO 2 sts, knit to end—18 (20, 22, 27, 30) sts rem. **Next row:** (WS) BO 8 (9, 10, 12, 14) sts, purl to end—10 (11, 12, 15, 16) sts rem. **Next row:** (RS) BO 1 st, knit to end—9 (10, 11, 14, 15) sts rem. BO all sts.

#### SLEEVES

CO 74 (77, 80, 83, 86) sts. Beg and ending with a purl row, work 9 rows in St st. **Next row:** (RS) Work corded edge, working into sts of CO. Purl 2 rows. Knit 3 rows. Work 4 rows in St st. Purl 1 RS row. Work 5 rows in St st. **Inc row:** (RS) K1, M1, knit to last st, M1, k1—2 sts inc'd. Work 5 rows even. Rep Inc row—78 (81, 84, 87, 90) sts. Work even in St st until piece measures 3" from last purl ridge, ending with a WS row. **Shape cap:** BO 4 sts at beg of next 2 rows—70 (73, 76, 79, 82) sts rem. **Dec row:** (RS) K2tog, knit to last 2 sts, k2tog—2 sts dec'd. Rep Dec row every RS row once more—66 (69, 72, 75, 78) sts rem. Work 3 rows even. Rep Dec row. Rep last 4 rows 2 more times—60 (63, 66, 69, 72) sts rem. Work 1 (3, 5, 7, 9) row(s) even. Rep Dec row every RS row 12 times—36 (39, 42, 45, 48) sts rem.

**Next row:** (WS) P2tog, purl to last 2 sts, p2tog—34 (37, 40, 43, 46) sts rem. **Next row:** (RS) [K2tog] 2 times, knit to last 4 sts, [k2tog] 2 times—30 (33, 36, 39, 42) sts rem. Dec 1 st each edge every row 3 times—24 (27, 30, 33, 36) sts rem. **Next row:** (RS) [K2tog] 2 times, knit to last 4 sts, [k2tog] 2 times—20 (23, 26, 29, 32) sts rem. Dec 1 st each edge every row 5 times—10 (13, 16, 19, 22) sts rem. **Next row:** (RS) [K2tog] 2 times, knit to last 4 sts, [k2tog] 2 times—6 (9, 12, 15, 18) sts rem. BO all sts.

#### FINISHING

Steam and block pieces lightly. Sew shoulder seams. Sew in sleeves. Sew sleeve and side seams. Sew selvedge edges of ruffle tog at back neck, making sure ruffle isn't twisted. Align ruffle seam with center back neck of body and pin in place. Pin ruffle to front and back neck edges of body, easing as needed. Sew ruffle to body as neatly as possible. Overcast selvedges on WS for a neat finish. Weave in loose ends. Steam all seams.

**Andrea Babb** comes from a long line of Newfoundland knitters. She works as a colorist and designer in the carpet industry but dreams of being able to knit full-time some day.



**CASCADE YARNS**  
DISTRIBUTOR OF FINE YARN

New from Cascade Yarns  
**220 Sport**  
100% Peruvian Highland Wool

Available in 50 colors

Download the Nancy Rieck Pattern free at [cascadeyarns.com](http://cascadeyarns.com)

f t e ravelry

**HALCYON YARN**  
12 SCHOOL ST. BATH, ME 04530 • [HALCYONYARN.COM](http://HALCYONYARN.COM)  
800-341-0282 • Call for your free catalog!

Start Saving Ruby Dollars!  
Receive Five Ruby Dollars for every purchase over \$40. Call or go online for details.

**LILY OF THE VALLEY SHELL**

SIGNATURE GEMSTONE SILK, AVAILABLE IN TWENTY COLORS.  
PATTERN #1590001P FREE WITH PURCHASE OF YARN.

# Fearless *Fair Isle* Knitting

*I'm still surprised at how often people tell me they just "can't do" Fair Isle knitting. Their fear is two-pronged: fear of choosing colors and fear of the techniques involved. They're convinced that they lack the skills required for both. However, traditional Fair Isle knitting has built-in "rules" for both.*

MARY JANE  
MUCKLESTONE

## Getting Started with color

# 1

These traditional approaches to color and technique, developed with efficient use of time and materials in mind, stem from the practicality of the frugal population of remote Fair Isle. Belonging to the Scottish Shetland Island group, this windswept island is located where the Atlantic Ocean meets the North Sea. The islanders developed colorful, warm garments flexible enough to work in. The distinctive patterning of Fair Isle knitting is a clever way to combine the many odd bits of different-colored yarn that came originally from the native Shetland sheep, which have evolved a variety of natural fleece colors. And the islanders knitted with two yarns to create two layers that trap air and create warmth.

Although I've mentioned "rules," Fair Isle knitting is a living tradition with styles that change continually. There are no "right" ways to do things, only ways that please you.

### Overcoming Color-Choice Fears

On Fair Isle itself, knitters first had access only to the varied colors of the native sheep. Natural dyestuffs were eventually imported from the North Sea trade routes. The early museum examples of Fair Isle knitting use a limited range of colors: natural Shetland black and white, imported indigo for blue, madder for red, and local plant dyes for yellow. The introduction of synthetic dyes in the 1920s widened the palette. By the 1980s, when Alice Starmore's landmark *Book of Fair Isle Knitting* was published (Taunton, 1988), Shetland wool was available in hundreds of colors. The style was a sophisticated, painterly blending of pattern and background colors. When I visited Shetland this past summer, the look was trending back toward lively contrasting colors.

The sheer number of available colors can be overwhelming. Here are some tips to get you going.

- Choose your colors in clear natural daylight.
- Begin with a pile of colors that you like.
- Separate the pile into a group of light colors and a group of dark colors. The most important aspect of each color is its *value*: its relative darkness or lightness (see box).
- Arrange each color group further in a value sequence from dark to light.
- Choose three colors from each group: a darkest color, a medium color, and a lightest color.
- Select a couple of crazy or odd colors you might want to use as occasional accents. Set them off to the side.
- Line up your choices next to each other. Is there enough contrast between the corresponding groups? The darkest color of the light group should be lighter than the lightest color of the dark group. Designate one group as pattern colors and the other as background colors.
- After you've settled on your colors, give them a test run before swatching. Try wrapping several strands of each color around a card or flat stick in the sequence you want to use. Or make I-cord snakes, knitting an inch or two of each color, and carry them around for a day to see how they look in different lights.

Knitting  
with color

2

Begin your project with just two of your colors, using small-footprint peerie patterns of just a few rows. Doing so will give you a chance to practice your technical skills and see how some of your color choices work.

Follow with a larger border pattern using more of your colors. Arrange each color group in a reflecting order around the center. Traditionally, center rows were all of one color or a single center row was tricked out in a wild color. This oddball color—I call it “poison,” borrowing a term from rug-hooking—can accent and emphasize the broader palette by contrast.

Have some fun! You should now be well on your way to continuing the fine knitting traditions of Fair Isle.



unblocked fabric

border pattern

peerie pattern

3 Overcoming  
Technical  
Fears

There’s an approach that addresses every Fair Isle knitting fear. Here are some common anxieties and ways to overcome them.

**Too Many Colors** In traditional Fair Isle knitting, you never have more than two colors in any row, ever. One color is for the pattern motif stitches, and the other is for the background stitches. You have only two yarns to work with at any time.

**Twisting Yarns** Simply keep one ball of yarn on each side of your body, well away from each other. Unless there are only one to three rounds before you use a yarn again, break it each time you finish with that color.

**Yarn Dominance** As you knit, you may notice that one color—that of either the pattern stitches or the background stitches—will appear to slightly dominate the other. This occurs because one strand of yarn is coming from under the other, resulting in slightly longer stitches. Be *consistent* in holding your yarn. Designate one position for your pattern color and one position for your background color. Determine which yarn is dominating, then note how you’re holding that particular yarn. This is your personal way of holding the “dominant yarn,” which in future, you’ll assign to the pattern color.

Finding Value in color

In Fair Isle knitting, the value of your colors is more important than the actual hues. Value is how close a particular shade is to white or black. **To find the value of a color, try these tricks:**

- Scan yarn samples in black and white.
- Take a picture of yarn samples and convert it to gray scale.
- Hold a red or green piece of cellophane over your yarns to cancel out their hues.



accent colors



dark group

light group



color test run

**Yarn Control Anxiety** You can hold the yarns several ways. By experimenting, you can decide which method works best for you. Most common is holding one yarn in each hand—two colors, two hands.



I carry both yarns in my left hand and use a continental form of “picking” the yarns.



On Shetland, I've seen women knitting with both yarns in their right hand.



Like any new skill, working with two yarns can be frustrating at first. However, just as you learned to knit with one yarn, you can learn to work with two. As with most things, practice makes perfect.

**Fear of Floats** Fair Isle knitting is more properly called stranded knitting. As you knit with one color, the yarn not in use is carried across the back of the work, cre-

ating strands called floats. Traditional Fair Isle patterns rarely have more than seven or eight stitches between color changes, so the floats will never be too long.

**Bunchy Fabric** As you happily knit along, stay relaxed and spread out your work along the right-hand needle as you go. This way, when you strand the unused yarn behind the working stitches, it will automatically be the correct length. With practice, smoothing out your just-knitted stitches will become second nature, and you'll avoid the puckering that occurs when the floats are too short.

Does your work still look bunched? Proper finishing will eliminate the worst of it. Give your item a good wet blocking. Wash it carefully in a mild soap and rinse thoroughly. Gently press out the moisture between towels and dry flat, pinning it into shape. On Shetland, they have special “wooly boards” or “wooly horses” designed just for drying garments in shape. Washing also brings out the “bloom” of Shetland wool, that lovely halo of fibers that visually soften and blend the colors and patterns.

**Alarming Color Charts** Traditional Fair Isle knitting employs geometric patterns that have a logical sequence, making them easy to remember. Fair Isle knitting is knitted in the round. On a chart, each square represents a knitted stitch, either a pattern stitch or a background stitch. Every row of the chart represents a pattern repeat that continues around the piece. Read from right to left, from bottom to top.

It's a worthwhile habit to learn to “read” your work. Really *look* at your knitting. Watch the pattern emerge from the background. A nice trick is to place a Post-it note over the rows you've worked just under the current row. By reading your work, you'll see where you've been and by consulting the chart, see where you'll be going.

**Loose Ends** Weaving in loose ends is a necessity, but it's not necessarily evil. One idea is to weave the end of the old yarn in while joining the new yarn. Leave the beginning of the new yarn to weave in later, after you've progressed a few inches. I try to weave the ends back into their same row in the direction they're coming from.

Now, I'll ‘fess up’ with what I do and offer a couple of additional ideas. Usually, I don't weave in any of my ends till the bitter end. I think of these unruly friends as a

project separate unto itself. You might also consider eliminating ends altogether by spit-splicing old and new colors together. And finally, in Shetland, they sometimes don't weave the ends in at all but knot them. Imagine deliberately creating knots—it could be liberating!



blocked fabric, wrong side



blocked fabric, right side

Just as Parmigiano-Reggiano comes only from Parma, true Fair Isle knitting comes from only the knitters of Fair Isle. That said, the possibilities for working with Fair Isle techniques are endless! We're lucky to have the Fair Isle knitters' hundreds of years of expertise to guide us in creating our own personal Fair Isle style. ■

**Mary Jane Mucklestone** is working on a book of Fair Isle motifs to be published by Interweave in Fall 2011. She loves to spread Fair Isle love through lively, fun, and informative classes. Keep up with her at [www.MaryJaneMucklestone.com](http://www.MaryJaneMucklestone.com).

# HEICHI

BY SHIBUI



SHADOW BY SARA MORRIS IN TAR  
503.595.5898 shibuiknits.com

Save up to  
**25% off**  
with WEBS®  
yarn & book  
discount!



Pattern Shown: #326 Sienna Pullover knit in Valley Yarns Southwick.  
Pattern \$1.99 download

WEBS is your complete source for name brand, high-quality yarn and supplies for knitting enthusiasts of all levels.

- Join our email list for special deals and more
- Shop our catalogs
- FREE patterns
- Closeouts up to 70% off

 Become a fan of WEBS:  
facebook.com/websyarn

 twitter.com/kathyelkins &  
twitter.com/websyarnstore



America's Yarn Store®

yarn.com

visit our store: 75 Service Center Rd., Northampton, MA | 1.800.367.9327

# Block by Block

3 technique tweaks  
bring color-block  
knitting into the  
modern world

1

A faux seam of reverse stockinette—  
with old and new yarns held together—creates a  
strong textured join between color panels.

**VICTORIA MYERS** says: "With this method for working intarsia, I managed to get past my memories of wonky animals splayed across squeaky acrylic back-grounds. I made friends with the technique." The **GARDEN PLOT DRESS** contrasts color and lace blocks to create a swiny dress fit for any garden party. **PAGE 46. YARN** Lion Brand LB Collection Cotton Bamboo



Almost-intarsia: **AMANDA SCHEUZGER'S CRANBERRY ISLAND THROW** places blocks of color in circles for a fresh blanket inspired by modern quilts. **PAGE 50.** **YARN** Brown Sheep Lamb's Pride Bulky



**2** Join as you knit with decreases and picked-up stitches to create a seamless knit with a graphic, pieced look.



**3** Shaped intarsia uses increases and decreases on either side of a color change to create a smooth curving line.

Intarsia for the thinking knitter: **DANIELA NII'S HOURGLASS PILLOWS** show off bold curving lines without a single stair step. **PAGE 52.** **YARN** Tahki Coast





## GARDEN PLOT DRESS

Victoria Myers

**Finished Size** 21½ (24, 26, 28)" chest circumference; to fit size 2 (4, 6, 8). Dress shown measures 24".

**Yarn** Lion Brand LB Collection Cotton Bamboo (52% cotton, 48% bamboo; 245 yd [224 m]/100 g): #174 snapdragon (MC), 2 (2, 3, 3) balls; #098 magnolia (CC), 2 balls.

**Needles** Size 6 (4 mm). Size 4 (3.5 mm): 16" circular (cir) and set of double-pointed (dnp). Adjust needle size if necessary to obtain the correct gauge.

**Notions** Markers (m); 2 small stitch holders; 1 large stitch holder; tapestry needle.

**Gauge** 20 sts and 26 rows = 4" in St st on larger needles; 24 sts and 32 rows = 4" in St st on smaller needle.

### NOTES

- The skirt of this dress uses four separate strands of yarn. At the color changes, both strands are held together to create a fake seam (purling on the right-side rows, and knitting on the wrong-side rows).

### Stitch Guide

**Picot Cast-on:** Using the knitted method (see Glossary), \*CO 5 sts, BO 2 sts, sl rem st from right needle to left needle; rep from \* for desired number of sts—each rep adds 3 sts.

### SKIRT PANEL (MAKE 2)

With MC, larger needles, and using the picot method (see Stitch Guide), CO 138 (147, 153, 171) sts. Using the knitted method only, CO 1 (0, 2, 0) more st(s)—139 (147, 155, 171) sts. Work in intarsia with a separate strand of yarn for each section as foll:

**Row 1:** (RS; set up color panels) With MC, k34 (36, 38, 42); with MC and new strand of CC held tog, p1; with CC, k34 (36, 38, 42); with CC and new strand of MC held tog, p1; with MC, k34 (36, 38, 42); with

MC and new strand of CC held tog, p1; with CC, k34 (36, 38, 42).

**Row 2:** With CC, p34 (36, 38, 42); with CC and MC held tog (closest strands), k1; with MC, p34 (36, 38, 42); with MC and CC held tog (closest strands), k1; with CC, p34 (36, 38, 42); with CC and MC held tog (closest strands), k1; with MC, p34 (36, 38, 42).

**Next row:** With MC, k34 (36, 38, 42); with MC and CC held tog, p1; with CC, work Row 51 (39, 27, 1) of Lace chart over 34 (36, 38, 42) sts; with CC and MC held tog, p1; with MC, k34 (36, 38, 42); with MC and CC held tog, p1; with CC, work Row 51 (39, 27, 1) of Lace chart to end.

**Next row:** With CC, work Row 52 (40, 28, 2) of Lace chart; with CC and MC held tog, k1; with MC, p34 (36, 38, 42); with MC and CC held tog, k1; with CC, work Row 52 (40, 28, 2) of Lace chart; with CC and MC held tog, k1; with MC, p34 (36, 38, 42). Cont in patt through Row 138 (132, 126, 120) of chart and **at the same time** dec 1 st each end of each MC section as foll, dec on same rows as chart narrows by 1 st at each side: ssk, knit to last 2 sts of MC section, k2tog—67 (75, 83, 91) sts rem when chart is complete. **Waist:** Change to smaller cir needle and MC.

**Next row:** (RS) Knit, dec 3 (3, 5, 7) sts evenly spaced—64 (72, 78, 84) sts rem. Knit 3 rows. Place sts on holder.

### BODICE

With smaller cir needle, k64 (72, 78, 84) front skirt-panel sts, place marker (pm), k64 (72, 78, 84) back skirt-panel sts—128 (144, 156, 168) sts. Pm and join in the rnd. Work in St st (knit every rnd) until piece measures 2 (2½, 3, 4)" from last garter ridge. **Shape armholes and**

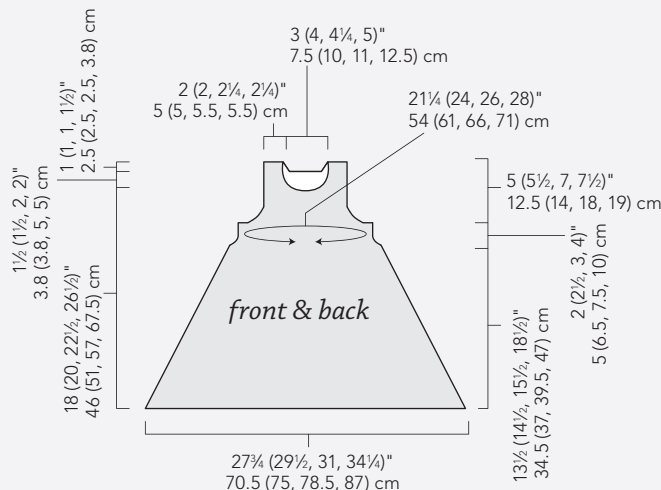





Distributed by: *The* **VARN SISTERS** *Inc.*  
 call: 877.582.2900 | www.theyarnsisters.com

softer  
warmer  
lighter **zealana.**  
*The light, soft touch of new zealand*



Lake House Henley  
 Designed by Michael del Vecchio

we salute •  
**Cat Bordhi**  
 author • teacher • designer

We're so pleased that Cat has tested and wholeheartedly endorses Frog Tree Pediboo yarn  
 Merino Wool washable/  
 Bamboo Viscose

the **Frog Tree** COLLECTION  
 A NOT-FOR-PROFIT COMPANY [www.FrogTreeYarns.com](http://www.FrogTreeYarns.com)

**COTTON SUPREME** | BOOK TWO

**Summer Supreme**

11 summer projects for adult women and young girls, accompanied by pin-on appliqué and fun stuffed toys for every age.

Dress yourself in the comfort of cotton!



**UNIVERSAL YARN**  
[www.universalyarn.com](http://www.universalyarn.com)

Available only in fine yarn stores. Distributed by Universal Yarn.

**front neck:** BO 5 (6, 6, 7) sts, knit to m, place next 64 (72, 78, 84) sts on holder for back—59 (66, 72, 77) sts rem for front. Working back and forth in rows, BO 5 (6, 6, 7) sts at beg of next row—54 (60, 66, 70) sts rem. Dec 1 st at each armhole edge

on next row, then every 6th row 5 more times. **At the same time**, when piece measures 4½ (5½, 7, 8)" from last garter ridge, shape neck as foll: Mark center 14 (18, 20, 24) sts. Work to m, join new yarn and BO 14 (18, 20, 24) sts, work to end.

Working both sides at the same time, dec 1 st at each neck edge on next RS row, then every 4th row 1 (2, 2, 2) more time(s)—12 (12, 14, 14) sts rem for each shoulder after all shaping is complete. Work even until piece measures 7 (8, 10, 11½)" from last garter ridge. Place sts on holders. **Shape armholes and back neck:** With RS facing, place back sts onto smaller cir needle. Working back and forth, BO 5 (6, 6, 7) sts at beg of next 2 rows—54 (60, 66, 70) sts rem. Dec 1 st at each armhole edge on next row, then every 6th row 5 more times. **At the same**

- k on RS; p on WS
- yo
- k2tog
- ssk
- sl 1, k2tog, pss0
- pattern repeat
- size 21¼"
- size 24"
- size 26"
- size 28"

Lace

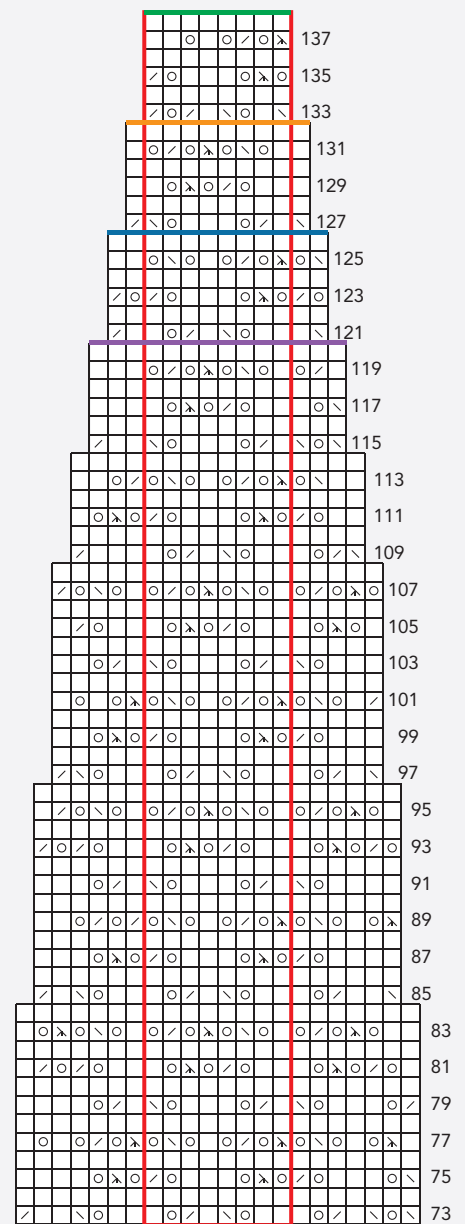
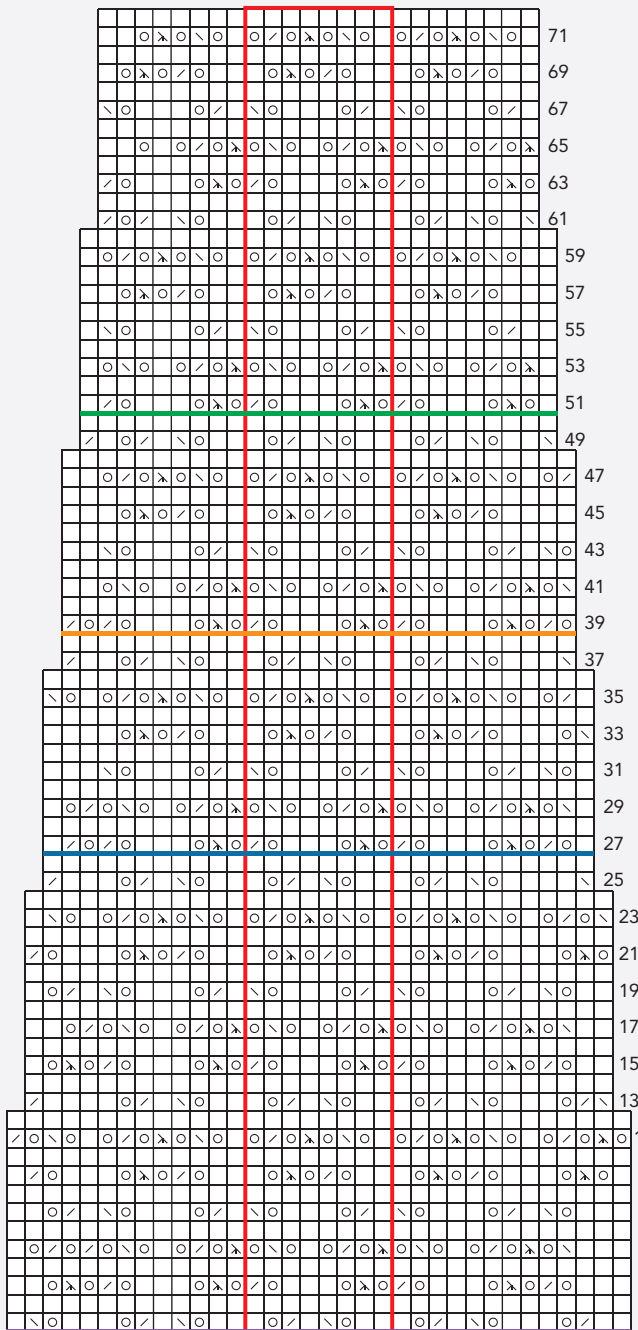

# KOIGU, WELCOME TO THE FAMILY!



Jimmy Beans Wool now carries over 100 colors of KPPPM.  
*(there's a color for everyone!)*

jimmy beans wool



YOUR LOCAL YARN STORE... ONLINE!  
WWW.JIMMYBEANSWOOL.COM (877) JBW - KNIT (529-5648)  
VISIT OUR SHOP IN RENO, NV FOLLOW US   



The perfect tools to craft perfection  
signatureneedlearts.com

**time**, when piece measures 6 (7, 9, 10)" from last garter ridge, shape neck as foll: Mark center 16 (20, 22, 26) sts. Work to neck m, join new yarn and BO 16 (20, 22, 26) sts, work to end. Working both sides at the same time, dec 1 st at each neck edge every RS row 1 (2, 2, 2) time(s)—12 (12, 14, 14) sts rem for each shoulder. Work even until piece measures 7 (8, 10, 11½)" from last garter ridge. Do not BO.

### FINISHING

With RS tog, join shoulders using three-needle BO (see Glossary). With MC threaded on a tapestry needle, sew side seams. **Neck edging:** With CC and smaller cir needle, pick up and knit 94 (108, 118, 144) sts evenly spaced around neck opening. Pm and join in the rnd. Purl 1 rnd. BO all sts. **Armhole edging:** With CC and dpn, pick up and knit 60 (66, 84, 90) sts evenly spaced around armhole opening. Pm and join in the rnd. Purl 1 rnd. BO all sts. Weave in ends. Steam-block to open up lace patt.

*Victoria Myers* is the owner of Island Yarn Company in Waltham, Massachusetts. There she attempts to maintain a fabulous daughter, store, and life inside a whirling tornado of yarn.



## CRANBERRY ISLAND THROW

Amanda Scheuzger

**Finished Size** 30½ (44½, 44½)" wide and 30½ (44½, 58½)" long. Shown in size 44½" × 44½".

**Yarn** Brown Sheep Lamb's Pride Bulky (85% wool, 15% mohair; 125 yd [114 m]/113 g): #M116 camel back (MC1) and #M10 creme (MC2), 2 (4, 5) skeins each; #M124 Persian peacock (CC1), 2 (3, 3) skeins; #M191 kiwi (CC2), #M162 mulberry (CC3), and #M181 prairie fire (CC4), 1 (1, 2) skein(s) each.

**Needles** Size 11 (8 mm): one 24" and two 40" circulars (cir) and set of double-pointed (dpn). Adjust needle size if necessary to obtain the correct gauge.

**Notions** Markers (m); waste yarn for provisional CO and to use as stitch holders; tapestry needle.

**Gauge** 12 sts and 16 rnds = 4" in St st; each block measures 14" square.

### NOTES

- Each block begins with a circle, knit in the round from the center out. Then a contrasting color ring is worked perpendicularly around the circumference of the circle by joining the last stitch of the ring to a live stitch from the circle. The square shape is constructed by picking up stitches around the ring and working each quadrant out toward the corner, using short-rows to shape the corners.
- Blocks are joined using three-needle bind-off. First, join pieces to form a strip, then join the long strips together in one continuous bind-off to reduce the number of ends to weave in.

### Stitch Guide

**Block A (make 1 [3, 3]):** Use MC1 for MC and CC1 for CC.

**Block B (make 1 [2, 3]):** Use MC1 for MC and CC2 for CC.

**Block C (make 1 [2, 3]):** Use MC2 for MC and CC3 for CC.

**Block D (make 1 [2, 3]):** Use MC2 for MC and CC4 for CC.

### BLOCK (MAKE 4 [9, 12]; SEE STITCH GUIDE)

**Inner circle:** With MC and dpn, CO 8 sts, leaving a 12" tail. Place marker (pm) and join in the rnd. Cont as foll, changing to shorter cir needle when possible:

**Rnd 1 and all odd rnds:** Knit.

**Rnd 2:** \*K1, M1R; rep from \* to end—16 sts.

**Rnd 4:** \*K2, M1R; rep from \* to end—24 sts.

**Rnd 6:** \*K3, M1R; rep from \* to end—32 sts.

**Rnd 8:** \*K4, M1R; rep from \* to end—40 sts.

**Rnd 10:** \*K5, M1R; rep from \* to end—48 sts.

**Rnd 12:** \*K6, M1R; rep from \* to end—56 sts.

**Rnd 14:** \*K7, M1R; rep from \* to end—64 sts.

**Rnd 16:** \*K8, M1R; rep from \* to end—72 sts.

**Rnd 18:** \*K9, M1R; rep from \* to end—80 sts.

## Tech Tip

This project contains a lot of small short-rows. To avoid having to turn your work constantly, you'll find it useful to knit backward or from left to right.



Insert left needle into stitch on right needle as shown. Bring yarn over, then under left needle and draw through stitch on right needle. Remove stitch from right needle.

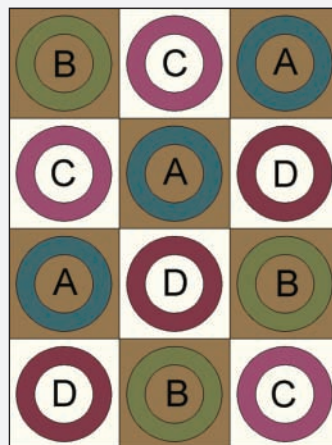

44½" × 58½"

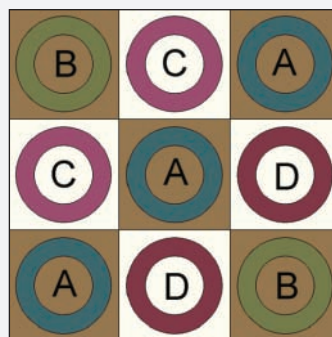

44½" × 44½"

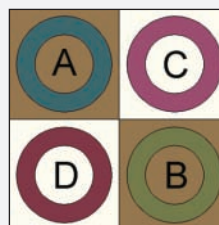

30½" × 30½"

# Pick Your Pocket

Charming child's pullover pattern has a choice of four pocket designs. Perfect for boys and girls alike!

Place an order by April 15, 2011, and  
**Receive \$5.00 off any order!**

Minimum order of \$10.00.

Use promo code IK11SP.

**Patternworks™**  
Everything for the hand knitter & crocheter!

Visit [www.patternworks.com](http://www.patternworks.com) to see more kids patterns, or call 1-800-438-5464 to order.



#802067 Child's Pullover



Featuring 101 of the biggest, smallest, and most amazing knits of all-time

**ASTOUNDING KNITS!**

101 Spectacular KNITTED CREATIONS AND Daring Feats

Lela Nargi

YOU'LL NEVER LOOK AT KNITTING THE SAME WAY AGAIN.

Available at Your Favorite Book or Craft Store.

[www.VoyageurPress.com](http://www.VoyageurPress.com)

CRAFTSIDE

[www.craftside.typepad.com](http://www.craftside.typepad.com)



Introducing **NEW Layers:** color upon color produces subtle, magical effects.

Also **NEW Rapport:** 66% Bamboo & 34% Cotton

To purchase these patterns, send \$12.00 to:  
Prism Book 60 • 3140 39th Avenue North • St. Petersburg, FL 33714  
OR contact us at [patterns@prismyarn.com](mailto:patterns@prismyarn.com)

To find a retail store & view all styles & colors, visit  
[www.prismyarn.com](http://www.prismyarn.com)

**Rnd 19:** Knit.

Break yarn; leave sts on needle. **Ring:** With WS facing and CC, use a provisional method (see Glossary) to CO 6 sts onto right needle, turn.

**Row 1:** (RS) K5, ssk (last CC st with next MC st), turn.

**Row 2:** (WS) K6.

**Rows 3–10:** Rep Rows 1 and 2 four more times. Work short-rows (see Glossary) as foll:

**Row 11:** K4, wrap next st, turn.

**Row 12:** K4.

**Row 13:** K2, wrap next st, turn.

**Row 14:** K2.

Rep Rows 1–14 fifteen more times—6 CC sts and no MC sts rem. **Note:** Wraps do not need to be picked up. Break yarn, leaving an 18" tail. Remove waste yarn from provisional CO and place sts onto other end of cir needle. Graft ends of ring tog using Kitchener st (see Glossary). With MC tail threaded on a tapestry needle, pull tail through CO sts at center of circle to close hole. Fasten off. Weave in ends. **Corners:** With MC, RS facing, and shorter cir needle, work around edge of ring as foll: [Pick up and knit 1 st in each of next 28 garter ridges, pm] 4 times—112 sts total. Work back and forth using short-rows as foll:

**Row 1:** (RS) K23, wrap next st, turn.

**Row 2:** (WS) P17, wrap next st, turn.

**Row 3:** K15, wrap next st, turn.

**Row 4:** P13, wrap next st, turn.

**Row 5:** K11, wrap next st, turn.

**Row 6:** P9, wrap next st, turn.

**Row 7:** K7, wrap next st, turn.

**Row 8:** P5, wrap next st, turn.

**Row 9:** K4, wrap next st, turn.

**Row 10:** P3, wrap next st, turn.

**Row 11:** K2, wrap next st, turn.

**Row 12:** P1, wrap next st, turn.

**Row 13:** Working wraps tog with wrapped sts as you come to them, k4, M1L, [k2, M1L] 2 times, k6, do not turn—3 sts inc'd. Rep Rows 1–13 three more times—124 sts; 4 corners complete. Work in the rnd, working wraps tog with wrapped sts as you come to them, as foll:

**Rnd 1:** \*K7, M1R, [k2, M1R] 2 times, k3, pm, k17, remove m; rep from \* to end of rnd, leaving m at end of rnd in place—136 sts.

**Rnd 2:** \*Purl to 1 st before m, p1f&b, sl m, p1f&b; rep from \* 3 more times, purl to end—144 sts.

**Rnd 3:** Knit.

**Rnd 4:** Rep Rnd 2—152 sts.

Remove beg-of-rnd m. Place 38 sts on each side of block on a separate piece of waste yarn to hold until ready for joining. Block piece.

**ASSEMBLY**

Arrange completed blocks according to assembly diagram. Place live sts from one side of each of two adjacent blocks onto needles. With RS tog and using MC1, join blocks using three-needle BO (see Notes and Glossary), leaving a 12" tail at each end of BO seam. Rep until all blocks are joined. With tail threaded on a tapestry needle, use tail to tighten corner joins; weave in ends. **Edging:** Beg in center of one side, place all live sts around blanket perimeter onto 2 longer cir needles, about half on each needle, pm at each of 4 corners of blanket—304 (456, 532) sts. Pm and join in the rnd.

**Rnd 1:** With CC1, \*knit to m, picking up and knitting 1 st in corner between each pair of blocks as you come to them, sl m, M1L; rep from \* 3 more times, knit to end of rnd—312 (468, 546) sts.

**Rnds 2, 4, and 6:** Purl.

**Rnd 3:** \*Knit to 1 st before m, k1f&b, sl m, k1, k1f&b; rep from \* 3 more times, knit to end of rnd—8 sts inc'd.

**Rnds 5 and 7:** Rep Rnd 3—336 (492, 570) sts after Rnd 7.

BO all sts pwisely. Weave in ends.

Originally from the Midwest, *Amanda Scheuzger* now lives in beautiful Maine. She is a freelance designer, architect, and mother to two active boys. In order to increase her knitting time, she is working on mastering the art of knitting with a child in her lap.

• • • • •

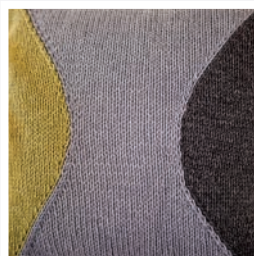

## HOURGLASS PILLOWS

Daniela Nii

**Finished Size** 14" square.

**Yarn** Tahki Coast (55% wool, 45% cotton; 126 yd [115 m]/50 g): #006 storm clouds (dark gray), #009 lichen (green), #001 white cliffs (white), and #005 fog (light gray), 3 skeins each.

**Needles** Size 7 (4.5 mm). Adjust needle size if necessary to obtain the correct gauge.

**Notions** Tapestry needle; four 14" pillow forms.

**Gauge** 18 sts and 24 rows = 4" in St st.

**NOTES**

- These pillows are worked using the intarsia method. Use a separate ball of yarn for each color area. On every row at each color change, twist yarns to avoid a hole by laying the strand just worked over the strand to be worked.
- The pillow is worked flat as two square panels that are then sewn together using mattress stitch (vertical and horizontal seams).

**Stitch Guide**

**Pillow 1, panel 1:** Use green for MC and white for CC1 and CC2.

**Tech Tip**

To make a smooth color edge using the shaped intarsia technique, make sure you work an increase on one side of the color change to pair with a decrease on the other side. Note that the total stitch count always stays the same.



Traditional Intarsia



Shaped Intarsia



**Pillow 1, panel 2:** Use green for MC, white for CC1, and dark gray for CC2.

**Pillow 2, panel 1:** Use white for MC and green for CC1 and CC2.

**Pillow 2, panel 2:** Use white for MC, dark gray for CC1, and green for CC2.

**Pillow 3, panel 1:** Use light gray for MC and dark gray for CC1 and CC2.

**Pillow 3, panel 2:** Use light gray for MC, dark gray for CC1, and green for CC2.

**Pillow 4, panel 1:** Use dark gray for MC and light gray for CC1 and CC2.

**Pillow 4, panel 2:** Use dark gray for MC, light gray for CC1, and green for CC2.

**PILLOW PANEL (MAKE 2 PER PILLOW; SEE STITCH GUIDE)**

With MC, CO 69 sts, leaving a tail about 45" long for seaming.

**Row 1:** (RS) Join CC1 (leaving a 10" tail for seaming), k8 with CC1 and carry MC along behind (twisting strands tog after 5 sts to catch float), k53 with MC, join CC2 (leaving a 10" tail for seaming), k8 with CC2.

**Row 2 and all WS rows:** Purl sts in colors as they appear.

**Hourglass bottom:**

**Row 3:** With CC1, k7, lifted inc (left slant) (LSI; see Glossary), k1, change to MC, ssk, k49, k2tog, change to CC2, k1, lifted inc (right slant) (RSI; see Glossary), k7—colors are now set up as foll: 9 CC1 sts, 51 MC sts, 9 CC2 sts.

**Row 5:** With CC1, k8, LSI, k1, change to MC, ssk, k47, k2tog, change to CC2, k1, RSI, k8—10 CC1 sts, 49 MC sts, 10 CC2 sts.

**Row 7:** With CC1, knit to 1 st before MC section, LSI, k1, change to MC, ssk, knit to 2 sts before CC2 section, k2tog, change to CC2, k1, RSI, knit to end—1 more CC st in each section and 2 fewer MC sts.

Rep Rows 6 and 7 thirteen more times—24 CC1 sts, 21 MC sts, 24 CC2 sts. **Hourglass neck:** [Work 3 rows even, then rep Row 7] 2 times—26 CC1 sts, 17 MC sts, 26 CC2 sts. Work 7 rows even, ending with a WS row. **Next row:** (RS)

With CC1, k24, k2tog, change to MC, k1, RSI, k15, LSI, k1, change to CC2, ssk, k24—25 CC1 sts, 19 MC sts, 25 CC2 sts.

Work 3 rows even. **Next row:** (RS) With CC1, k23, k2tog, change to MC, k1, RSI, k17, LSI, k1, change to CC2, ssk, k23—24 CC1 sts, 21 MC sts, 24 CC2 sts. Work 3 rows even. **Hourglass top:**

**Row 1:** (RS) With CC1, knit to 2 sts before MC section, k2tog, change to MC, k1, RSI, knit to 1 st before CC2 section, LSI, k1, change to CC2, ssk, knit to end—1 fewer CC st in each section and 2 more MC sts. Rep Row 1 every RS row 15 more times—8 CC1 sts, 53 MC sts, 8 CC2 sts. Work 3 rows even, ending with a WS row. BO all sts kwise in colors as they appear, leaving a 45" tail of MC and a 10" tail of each CC for seaming.

**FINISHING**

Block pieces to 15" square. Weave in ends, except long seaming tails. With CC1, sew side seams using mattress st (see Glossary) with a 1½-st seam allowance, taking care to align halves so that hourglass and direction of incs/decs run in same direction. Sew bottom seam using mattress st with 2-row seam allowance, using tail of each color over its respective section. Insert pillow form, then sew top seam using mattress st with 2-row seam allowance, using tail of each color over its respective section.

*Daniela Nii* started her adventures in knitwear as a first-grader in the shadows of the Swiss Alps. She uses a diverse range of techniques and media to produce designs that highlight simplicity and elegance. Her precious knitting time keeps her sane in a high-paced life with two young boys—make it three (her husband)—and her own software consulting business. You can follow her crafting projects on her blog at [www.nikkisstudio.blogspot.com](http://www.nikkisstudio.blogspot.com).

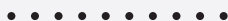

ASHFORD  
**WHEELS & LOOMS**

Wild Carder

Create beautiful, fun, funky & wild batts ready to spin. Add wool, silk, cocoons, noils, ribbons, bits, pieces and more...



Includes cleaning brush, clamps and doffer.

Joy Spinning Wheel

Spin your own beautiful yarns on the Joy spinning wheel. Ultra compact, flyer and bobbin store in the frame, fold up the Joy and take it with you. Sturdy canvas carrybag available. Choose single or double treadle.



Knitters Loom

Weave garments or home furnishings with textured, fun knitting yarns. Quick and easy instructions included. Fully assembled, ready to weave. 12 or 20 inch weaving widths.

*Just add yarn!*



Portability in 2 sizes, 12 or 20 inch weaving widths. Stands & carry bags available.



**USA Distributor:**  
Foxglove Fiberarts Supply  
Phone (206) 780-2747  
[www.FoxgloveFiber.com](http://www.FoxgloveFiber.com)



Lace first-timers take note:  
**MAUREEN HEFTI**'s beginner-friendly  
**RAIN ON THE PRAIRIE SCARF**  
dresses up simply framed eyelets with  
a luxurious yarn for a quietly elegant  
finished piece. **PAGE 58. YARN**  
Buffalo Gold Moon Lite

*Fabric*  
**Interrupted**

The openwork equation  
is simple: any intentional  
hole = lace.





The **LEAF AND PICOT CARDIGAN** scatters a delicate lace motif reminiscent of spring leaves across a classic silhouette edged with picot hems for structure. **LAURA GRUTZECK** uses a silk-and-wool blend with a dry, raw-silk finish for trans-seasonal versatility. **PAGE 58. YARN** Harrisville Designs Silk & Wool





Columns of simple eyelets grow and bloom into an exquisite Estonian lace motif in **SUSANNA IC's ROSE LACE STOLE**. Blocking opens up the lace pattern and creates deep, dramatic points. **PAGE 62.** YARN Manos del Uruguay Lace, distributed by Fairmount Fibers





< **TATIANA'S SWEATER** uses clever needle changes and circular knitting to work an undulating, staggered lace-and-cable motif as an all-over pattern, without sacrificing an hourglass shape. **RAYE SCHWARTZ. PAGE 66. YARN** Valley Yarns Valley Superwash

**CATHY CARRON** thinks differently about openwork: The **DROP MESH TEE**'s body, worked in dropped stitches, creates a delicate, stretchy sheer panel between solid-fabric raglan shoulders. **PAGE 70. YARN** Classic Elite Verde Collection Solstice



## RAIN ON THE PRAIRIE SCARF

Maureen Hefti

**Finished Size** 9½" wide and 42" long, after blocking.

**Yarn** Buffalo Gold Moon Lite (75% Tencel, 25% American bison down; 330 yd [304 m]/50 g): Tuscany, 1 skein.

**Needles** Sizes 5 (3.75 mm) and 3 (3.25 mm). Adjust needle size if necessary to obtain the correct gauge.

**Notions** Tapestry needle.

**Gauge** 25 sts and 40 rows = 4" in lace patt on smaller needles.

### NOTES

- Slip first stitch of every row pwise with yarn in front. Before knitting the next stitch, bring yarn to back of work, making sure not to pull yarn too tightly (thus ensuring a flexible edge).

### SCARF

With larger needles, loosely CO 58 sts. Change to smaller needles. Work in garter st (knit every row) until piece measures ½" from CO, ending with a RS row.

**Rows 1, 3, 5, and 7:** (WS) Sl 1 (see Notes), k3, p50, k4.

**Row 2:** (RS) Sl 1, k3, \*k2tog, yo; rep from \* to last 4 sts, k4.

**Row 4:** Sl 1, knit to end.

**Row 6:** Sl 1, k3, \*yo, ssk; rep from \* to last 4 sts, k4.

**Row 8:** Sl 1, knit to end.

Rep Rows 1–8 forty-seven more times—piece measures about 39" from CO. Work in garter st for ½". Use larger needle to BO loosely.

### FINISHING

Block to measurements. **Note:** Tencel may be fragile when completely wet, so use care and do not stretch too tightly. Weave in ends.

*Maureen Hefti* lives in Sacramento, California, where she dreams of cold weather

and warm woolen sweaters. She blogs about her adventures in knitting and life at [www.RavenousKnits.wordpress.com](http://www.RavenousKnits.wordpress.com).

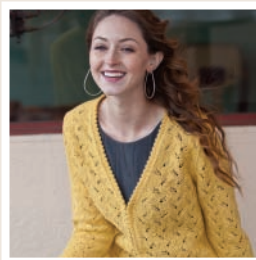
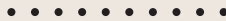

## LEAF AND PICOT CARDIGAN

Laura Grutzeck

**Finished Size** 33 (36, 39¼, 44¼, 46¼, 53¼)" bust circumference, with ½" front edgings meeting in center. Cardigan shown measures 39¼", modeled with about 7" ease.

**Yarn** Harrisville Designs Silk & Wool (50% silk, 50% wool; 175 yd [160 m]/50 g): #204 pale daffodil, 5 (6, 7, 7, 8, 9) skeins.

**Needles** Body and sleeves—size 6 (4 mm). Edgings—size 4 (3.5 mm): 36" to 40" circular (cir). Adjust needle size if necessary to obtain the correct gauge.

**Notions** Markers (m); tapestry needle; waste yarn; spare cir needle same size or smaller than edging needle; 4 (4, 4, 5, 5) hook-and-eye sets; sharp-point sewing needle and matching thread.

**Gauge** 21 sts and 30 rows = 4" in leaf lace patt on larger needles.

### NOTES

- The first and last stitches of each row are selvedge stitches; work all shaping inside these selvedge stitches.
- Use stitch markers to keep track of the lace pattern during shaping. When increasing, work any new stitches outside the markers in stockinette until there are enough stitches to add a complete nine-stitch repeat, then move the markers outward by nine stitches at each side and work the new stitches into the established pattern. When decreasing, if there are not enough stitches between the markers to work a complete nine-stitch repeat, work the stitches of any partial repeats in stockinette until they have been decreased away; move the markers inward by nine stitches as necessary to accommodate any further decreases.

- Look ahead during shaping and if there are not enough stitches to complete all four rows of a leaf motif, work those stitches in stockinette instead.

### Stitch Guide

**Leaf Lace Pattern:** (multiple of 9 sts + 3)

**Row 1:** (RS) K3, \*k2tog, k1, yo, k6; rep from \* to end.

**Row 2:** (WS) P1, \*p6, yo, p1, p2tog; rep from \* to last 2 sts, p2.

**Row 3:** K1, \*k2tog, k1, yo, k6; rep from \* to last 2 sts, k2.

**Row 4:** P3, \*p6, yo, p1, p2tog; rep from \* to end.

**Row 5:** Knit.

**Row 6:** Purl.

**Row 7:** \*K6, yo, k1, ssk; rep from \* to last 3 sts, k3.

**Row 8:** P2, \*p2tog tbl, p1, yo, p6; rep from \* to last st, p1.

**Row 9:** K2, \*k6, yo, k1, ssk; rep from \* to last st, k1.

**Row 10:** \*P2tog tbl, p1, yo, p6; rep from \* to last 3 sts, p3.

**Rows 11 and 12:** Rep Rows 5 and 6.

Rep Rows 1–12 for patt.

### BACK

With smaller cir needle and waste yarn, use the invisible provisional method (see Glossary) to CO 86 (94, 104, 114, 122, 140) sts. Beg with a WS purl row, work 5 rows in St st. **Picot turning row:** (RS) K1, \*k2tog, yo; rep from \* to last st, k1. Work 5 more rows in St st, ending with a WS row. Carefully remove waste yarn and place 86 (94, 104, 114, 122, 140) CO sts on spare cir needle. Fold piece in half along picot turning row with WS tog, RS facing out, and spare needle held behind edging needle. **Joining row:** (RS) \*K1 st from front needle tog with 1 st from back needle; rep from \* to end—86 (94, 104, 114, 122, 140) sts; folded hem measures about ½" high. Change to larger needles.

**Next row:** (WS) P1 (1, 1, 2, 1, 1), place marker (pm), purl to last 1 (1, 1, 2, 1, 1) st(s), work an M1 inc 0 (1, 0, 1, 0, 0) time, pm, p1 (1, 1, 2, 1, 1)—86 (95, 104, 115, 122, 140) sts. **Next row:** (RS) Knit to m, slip marker (sl m), work Row 1 of leaf lace patt (see Stitch Guide) to next m, sl m, knit to end. Working sts outside m in St st, cont in patt until piece measures 14½ (14¼, 15, 15¼, 15¾, 16)" from picot turning row, ending with a WS row.

**Shape armholes:** BO 6 (6, 6, 8, 8, 12) sts at beg of next 2 rows—74 (83, 92, 99, 106, 116) sts rem. **Dec row:** (RS) K1, ssk,



**WE COME FROM A GALAXY FAR FAR AWAY**

**JULY 28 - 31**  
[WWW.SOCKSUMMIT.COM](http://www.socksummit.com)

OUR SPONSORS TO DATE:

SIMPLY SOCKS	THE FOLD
THE LOOPY EWE	SKACEL
WEBS	XRX
LOUET	WOOL2DYE4
BLUE MOON FIBER ARTS	

*Friendly Patterns for the Average Knitter...  
 What's New!!!*



#61 Westport Boatneck  
 (sizes: 6 mos.-12 years)  
 (Shown in Plymouth Ashton)

**PATTERN FISH**  
 DESIGN by **Louise™**

P.O. Box 517 • Little Compton • RI 02837  
 Telephone 888.624.6517 • [www.designbylouise.com](http://www.designbylouise.com)  
 Available at your local yarn shop. Dealer inquiries welcome.

On Site or On Line...  
**[www.LetsKnit.com](http://www.LetsKnit.com)**  
 SAKONNET PURLS • 3988 Main Road • Tiverton, RI • 888.624.9902

unwinding a fresh ball of yarn is like giving stress a one-way ticket to nowhere.



**Carolina Homespun**  
[CarolinaHomespun.com](http://CarolinaHomespun.com)  
 Spin for peace. Create with fiber.

work in patt to last 3 sts, k2tog, k1—2 sts dec'd. Cont in patt, rep Dec row every RS row 2 (5, 7, 8, 9, 11) more times—68 (71, 76, 81, 86, 92) sts rem. Work even until armholes measure 7 (7½, 8, 8½, 10, 11)", ending with a WS row. **Shape neck and shoulders:** (RS) Work 18 (19, 20, 22, 24, 26) sts, join new yarn and BO center 32 (33, 36, 37, 38, 40) sts, work to end—18 (19, 20, 22, 24, 26) sts at each side. Working each side separately, at each armhole edge BO 6 (6, 7, 8, 8, 9) sts 2 times, then 6 (7, 6, 6, 8, 8) sts once—no sts rem.

## RIGHT FRONT

With smaller cir needle and waste yarn, use the invisible provisional method to CO 40 (44, 50, 56, 58, 68) sts. Work 5 rows in St st, picot turning row, 5 rows in St st, and joining row as for back hem—folded hem measures ½" high. Change to larger needles. **Next row:** (WS) P1 (3, 1, 4, 1, 1), pm, purl to last 1 (3, 1, 4, 1, 1) st(s), work an M1 inc 1 (1, 0, 0, 1, 0) time, pm, p1 (3, 1, 4, 1, 1)—41 (45, 50, 56, 59, 68) sts. Working sts outside m in St st, work center sts in leaf lace patt until piece measures 11½ (12, 12½, 13, 14½, 15½)" from picot turning row, ending with a WS row. **Shape neck and armhole:** Armhole shaping is introduced while neck shaping is in progress; read the next sections all the way through before proceeding to make sure you do not work past the point where the armhole shaping begins. **Neck dec row:** (RS) K1, ssk, work to end—1 st dec'd at neck edge. Rep neck dec row every 4th row 2 (2, 9, 9, 7, 10) more times, then every 6th row 11 (11, 6, 7, 9, 7) times—14

(14, 16, 17, 17, 18) sts total removed at neck edge. **At the same time,** when piece measures 14½ (14¾, 15, 15¾, 15¾, 16)" from picot turning row, shape armhole by BO 6 (6, 6, 8, 8, 12) sts at beg of next WS row, then dec 1 st at armhole edge every RS row 3 (6, 8, 9, 10, 12) times by working in patt to last 3 sts, k2tog, k1—9 (12, 14, 17, 18, 24) sts total removed at armhole edge. When all shaping has been completed, 18 (19, 20, 22, 24, 26) sts rem. Work even until armhole measures 7 (7½, 8, 8½, 10, 11)", ending with a RS row. **Shape shoulder:** BO 6 (6, 7, 8, 8, 9) sts at beg of next 2 WS rows, then 6 (7, 6, 6, 8, 8) sts at beg of foll WS row—no sts rem.

## LEFT FRONT

With smaller cir needle and waste yarn, use the invisible provisional method to CO 40 (44, 50, 56, 58, 68) sts. Work 5 rows in St st, picot turning row, 5 rows

## CUSTOMIZE IT

You may work partial repeats of the lace motif during shaping if desired. Just remember that if you don't have enough stitches to work a decrease, don't work the corresponding yarnover. Because the lace pattern has a lot of stretch, you can block the knitted pieces about ½ inch longer or wider than the given measurements if needed.



in St st, and joining row as for back hem. Change to larger needles. **Next row:** (WS) P1 (3, 1, 4, 1, 1), pm, purl to last 1 (3, 1, 4, 1, 1) st(s), work an M1 inc 1 (1, 0, 0, 1, 0) time, pm, p1 (3, 1, 4, 1, 1)—41 (45, 50, 56, 59, 68) sts. Working sts outside m in St st, work center sts in leaf lace patt until piece measures 11½ (12, 12½, 13, 14½, 15½)" from picot turning row, ending with a WS row. **Shape neck and armhole: Neck dec row:** (RS) Work to last 3 sts, k2tog, k1—1 st dec'd at neck edge. Rep neck dec row every 4th row 2 (2, 9, 9, 7, 10) more times, then every 6th row 11 (11, 6, 7, 9, 7) times—14 (14, 16, 17, 17, 18) sts total removed at neck edge. **At the same time,** when piece measures 14½ (14¾, 15, 15¾, 15¾, 16)" from picot turning row, shape armhole by BO 6 (6, 6, 8, 8, 12) sts at beg of next RS row, then dec 1 st at armhole edge every RS row 3 (6, 8, 9, 10, 12) times by working first 3 sts as k1, ssk—9 (12,

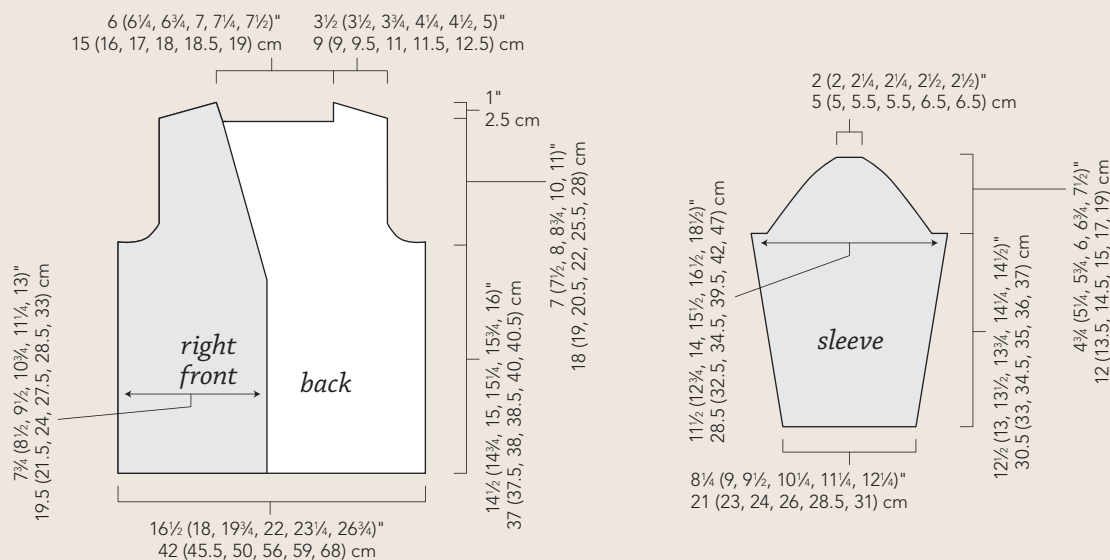

NEW from **XOXO** BOOKS

# Entrée to Entrelac

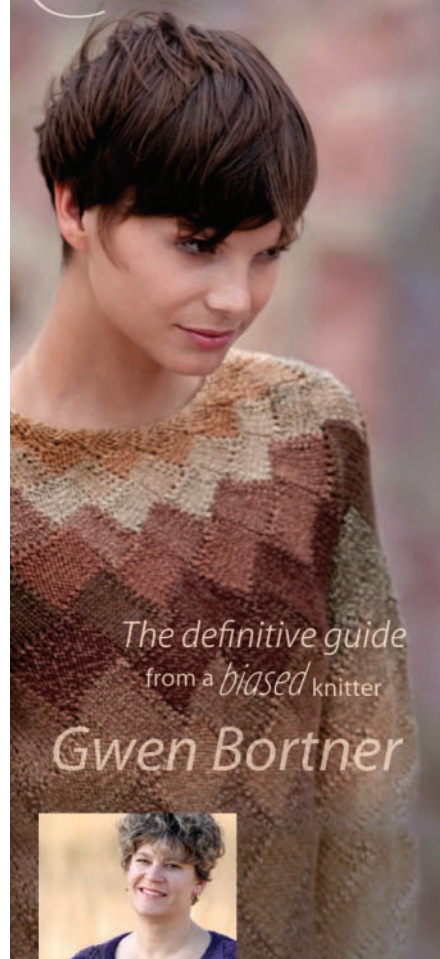

The definitive guide  
from a *biased* knitter

Gwen Bortner



a Unicorn Books  
Top-5 Bestseller  
for five months  
in a row

Available  
at yarn shops  
everywhere.

800-232-5648  
[www.knittinguniverse.com](http://www.knittinguniverse.com)



**CASCADE YARNS**  
DISTRIBUTOR OF FINE YARN

## LUNA

100% Peruvian Cotton

New Colors!  
63 Solids and Paints

Easy Care

Great Texture

Download the Susie Bonell  
Pattern free at [cascadeyarns.com](http://cascadeyarns.com)

## Wisteria



New for Spring from  
Knitting At KNoon  
Designs

[www.KnittingAtKNoon.com](http://www.KnittingAtKNoon.com)

Patterns for timeless knits 

616.538.0958



Find what you've been dreaming about...  
[WWW.WAGTAILYARNS.COM.AU](http://WWW.WAGTAILYARNS.COM.AU)



100% KID MOHAIR YARNS  
MOHAIR & MERINO WOOL BLENDS  
OVER 90 COLORS | PATTERNS



14, 17, 18, 24) sts total removed at armhole edge. When all shaping has been completed, 18 (19, 20, 22, 24, 26) sts rem. Work even until armhole measures 7 (7½, 8, 8¾, 10, 11)", ending with a WS row.

**Shape shoulder:** BO 6 (6, 7, 8, 8, 9) sts at beg of next 2 RS rows, then 6 (7, 6, 6, 8, 8) sts at beg of foll RS row—no sts rem.

### SLEEVES

With smaller cir needle and waste yarn, use the invisible provisional method to CO 42 (46, 50, 54, 58, 64) sts. Work 5 rows in St st, picot turning row, 5 rows in St st, and joining row as for back hem. Change to larger needles. **Next row:** (WS) P2 (4, 1, 3, 1, 4), pm, purl to last 2 (4, 1, 3, 1, 4) st(s), work an M1 inc 1 (1, 0, 0, 1, 1) time, pm, p2 (4, 1, 3, 1, 4)—43 (47, 50, 54, 59, 65) sts. Working sts outside m in St st, work center sts in leaf lace patt for 6 rows, ending with a WS row. **Inc row:** (RS) K1, M1, work in patt to last st, M1, k1—2 sts inc'd. Rep Inc row every 8th row 8 (9, 7, 1, 1, 0) more time(s), then every 6th row 0 (0, 4, 12, 12, 15) times, working new sts into patt (see Notes)—61 (67, 74, 82, 87, 97) sts. Work even until piece measures 12½ (13, 13½, 13¾, 14¼, 14½)" from picot turning row, ending with a WS row.

**Shape cap:** BO 6 (6, 6, 8, 8, 12) sts at beg of next 2 rows—49 (55, 62, 66, 71, 73) sts. **Dec row:** (RS) K1, ssk, work to last 3 sts, k2tog, k1—2 sts dec'd. Rep Dec row every RS row 14 (15, 15, 15, 19, 23) more times—19 (23, 30, 34, 31, 25) sts. Then dec 1 st each edge every row 4 (6, 9, 11, 9, 6) times, working WS dec rows as p1, p2tog, work to last 3 sts, p2tog tbl, p1—11 (11, 12, 12, 13, 13) sts rem. BO all sts.

### FINISHING

Wet-block pieces to measurements. Sew shoulder seams. **Front edging:** With smaller cir needle and RS facing, beg at lower edge of right front, pick up and knit 108 (112, 116, 122, 130, 137) sts up right front to shoulder seam, 42 (42, 46, 46, 48, 50) sts across back neck, and 108 (112, 116, 122, 130, 137) sts down left front—258 (266, 278, 290, 308, 324) sts. Work 5 rows in St st, picot turning row, then 5 rows in St st as for back hem, but do not work the joining row. Place sts on waste yarn. Fold hem in half along picot turning row and sew live sts in place with yarn threaded on a tapestry needle, matching each live st to the corresponding st in the pick-up row. Steam-block front

edging. Sew sleeves into armholes, then sew side and sleeve seams. Weave in ends. Mark positions for 4 (4, 4, 5, 5, 5) hook-and-eye sets along each front, the lowest ½" up from picot turning row, the highest at the start of the front neck shaping, and the rem sets evenly spaced in between. Sew hooks to WS of right-front edging and eyes to WS of left-front edging so fronts meet in the center and conceal the hooks when closed.

*Laura Grutzeck* lives in Philadelphia, Pennsylvania, with her husband and dogs. Although she has no blog or Facebook page, she is an avid Ravelry user. She is coauthor of *Knit So Fine: Knitting with Skinny Yarns* (Interweave, 2008).

• • • • •



## ROSE LACE STOLE

Susanna IC

**Finished Size** 21" wide and 72" long, after blocking.

**Yarn** Manos del Uruguay Lace (70% baby alpaca, 25% silk, 5% cashmere; 439 yd [401 m]/50 g): #L2103 Rosetta pink, 2 skeins. Yarn distributed by Fairmount Fibers.

**Needles** Size 7 (4.5 mm): 32" circular (cir). Size 9 (5.5 mm): 32" cir (for BO). Adjust needle size if necessary to obtain the correct gauge.

**Notions** Waste yarn; markers (m); tapestry needle; blocking pins.

**Gauge** 22 sts and 24 rows = 4" in St st on smaller needle, after blocking.

### NOTES

- The shawl is worked in two identical halves, each starting from the provisional cast-on in the center and worked outward to the pointed ends.

### Stitch Guide

**Sl2tog, k1, p2sso:** Sl 2 sts as if to k2tog, k1, pass 2 slipped sts over—2 sts dec'd.

**4-into-1 dec:** Sl 2 sts as if to k2tog, k2tog, p2sso—3 sts dec'd.

**3-into-7 inc:** Insert right needle into fronts of next 3 sts as if to k3tog. Work ([k1, yo] 3 times, k1) into the triple loop, then slip triple loop from left needle—4 sts inc'd.

### FIRST HALF

With waste yarn, smaller needle, and the invisible provisional method (see Glossary), CO 115 sts. Do not join.

**Row 1:** (RS) K2tog, yo, knit to last 2 sts, yo, ssk.

**Row 2:** Purl.

**Rows 3–12:** Rep Rows 1 and 2 five times.

**Row 13:** K2tog, yo, k6, \*yo, sl2tog, k1, p2sso (see Stitch Guide), yo, k13; rep from \* to last 11 sts, yo, sl2tog, k1, p2sso, yo, k6, yo, ssk.

**Row 14:** Purl.

**Rows 15–24:** Rep Rows 13 and 14 five times.

“Fragrant spring rose blossoms are the inspiration for this shawl featuring traditional Estonian stitches that resemble rose petals. The main body of the wrap is a simple and quick-to-knit geometric lace, which contrasts nicely with the more elaborate border stitches. Working beads into the lacy border will enhance the drape and add sparkle to the finished project, much like drops of morning dew sparkle on rose petals.”

—SUSANNA IC





**LION BRAND® YARN**  
OUR QUALITY SHOWS SINCE 1878  
LION BRAND YARNS

**58  
YARNS**

**790  
COLORS**

**OVER  
3,000  
FREE PATTERNS**

**LionBrand.com**  
FAMOUS FOR  
QUALITY SINCE 1878

**CASCADE YARNS**  
DISTRIBUTOR OF FINE YARN

**Ultra Pima**  
**100% Pima Cotton**

**Buttery Soft**

**New Colors  
Over 90 Solids  
and Quatros**

Download this Varian Brandon pattern free at [cascadeyarns.com](http://cascadeyarns.com)

f t ravelry

Called "Cables 101 Vest" by Janet Szabo, this project is great to learn about cable knitting. The cables are charted (and written out) so you can follow each cable step across the row; the set-up row right above the bottom ribbing gets you going in the right direction. Using **Cascade 220**, this vest is knit on size 5 and 7 needles plus a 16" circular size 5 for the armholes. This classy vest will stay in your wardrobe for years to come. Knit in traditional natural or choose from over 60 colors of Cascade 220 (colors shown on our website). Finished chest: 38" (42, 46).

**Yarn & Pattern:**  
KK-YB-1330 \$39.00 (39.00, 45.60) plus shipping.

Request our free **Knitting & Crochet Catalog**.

**YARN BARN of Kansas**  
930 Massachusetts Lawrence, KS 66044  
[www.yarnbarn-ks.com](http://www.yarnbarn-ks.com)  
**1-800-468-0035**

**YARNBARN**

## CUSTOMIZE IT

Because the shawl is worked seamlessly from a center temporary cast-on, you can easily customize its final size. By simply changing the number of the border pattern repeats and working fewer set-up geometric lace rows, the shawl can become a scarf. Instructions: Cast on 67 sts and work Rows 1–2 three times. Work Rows 13–14 three times, work Rows 25–26 twenty-five times, then work Rows 1–52 of Rose Bud Lace Border chart 3 times.



**Row 25:** K2tog, yo, k6, \*yo, sl2tog, k1, p2sso, yo, k5; rep from \* to last 3 sts, k1, yo, ssk.

**Row 26:** Purl.

**Rows 27–124:** Rep Rows 25 and 26 forty-nine times.

Work Rows 1–52 of Rose Bud Lace Border chart—117 sts. Change to larger needle.

**BO row:** (RS) \*K2tog, k1, return both sts to left needle; rep from \* until 2 sts rem, return both sts to left needle, k2tog, fasten off last st.

### SECOND HALF

Carefully unzip provisional CO and transfer 115 live sts to smaller needle. Join yarn with RS facing and work as for first half.

### FINISHING

Weave in ends, leaving tails 1" to 2" long. Block piece to measurements, pulling the points of the lace border along each short side. When completely dry, remove pins and trim yarn tails flush with the surface.

*Susanna IC* has an extensive background in studio arts and art history, which continue to inspire much of her knitting. Her projects and designs can be found at [www.artqualia.com](http://www.artqualia.com).

□ k on RS; p on WS

○ yo

↘ k2tog

↘ ssk

▲ sl2tog, k1, p2sso (see Stitch Guide)

⬆ 4-into-1 dec (see Stitch Guide)

■ no stitch

□ pattern repeat

7 3-into-7 inc (see Stitch Guide)

### Rose Bud Lace Border

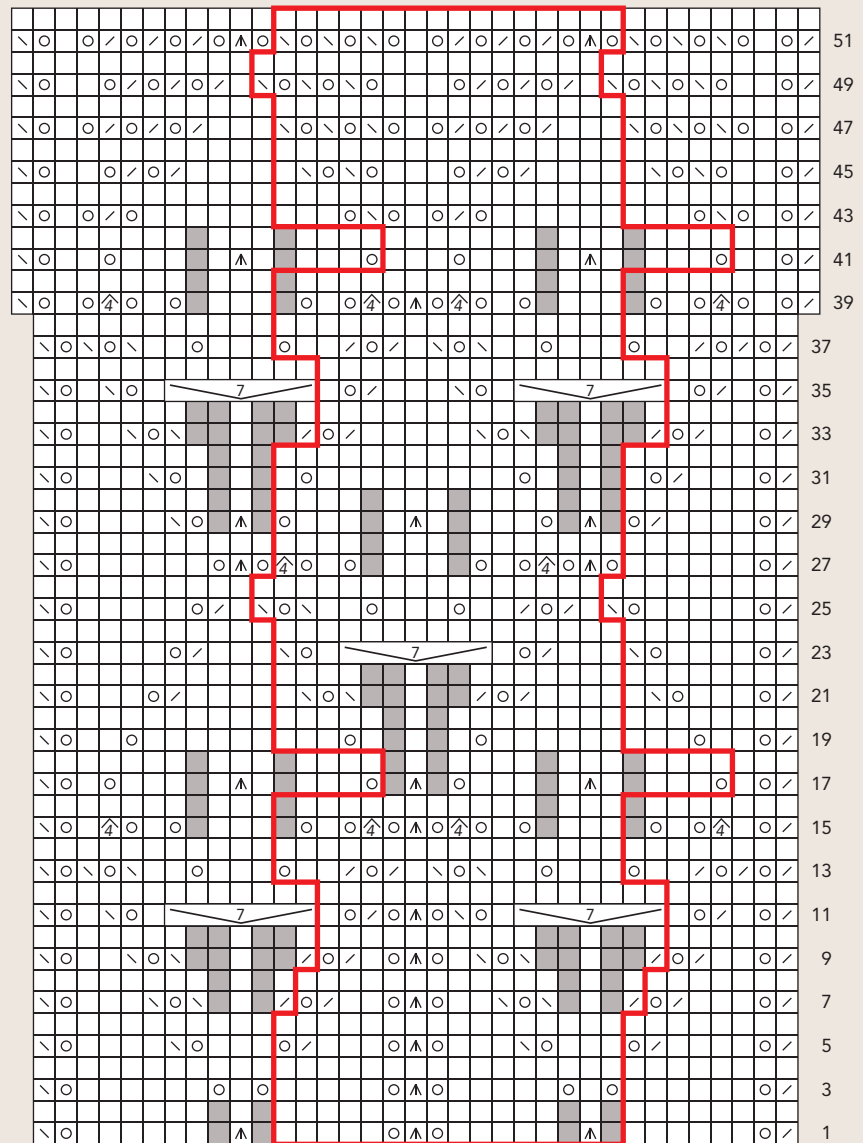



# Stainless Steel Sock Blockers

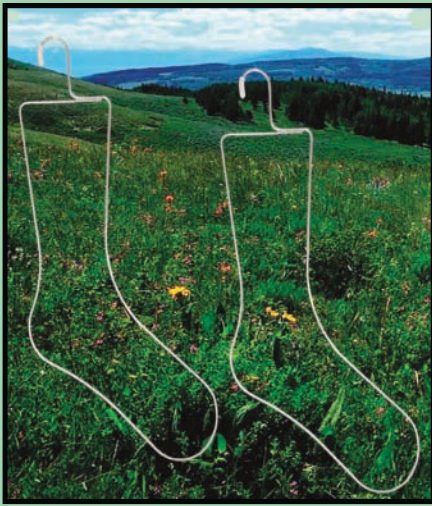

More air flow for faster drying!

for your nearest retailer  
visit [www.brysonknits.com](http://www.brysonknits.com)  
800-544-8992

**Bryson Distributing**



BE SWEET

Dierdre Dress  
Candy Sprinkles  
Bambino Taffy

pic by Sasha Gullish

[www.besweetyarns.com](http://www.besweetyarns.com)



#C815

*Straker Classics*  
ALWAYS IN STYLE

view collection and find yarns shops near you at [www.strakerclassics.com](http://www.strakerclassics.com)  
wholesale orders at 508-990-0679 or [pstraker@comcast.net](mailto:pstraker@comcast.net)



The Fibre  
Company  
[www.kelbournewoolens.com](http://www.kelbournewoolens.com)

COLLECTION 3: SCARVES + SHAWLS

Linden by Courtney Kelley



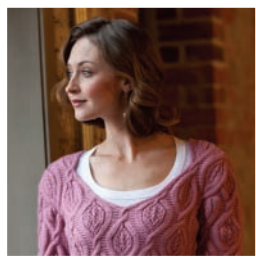

## TATIANA'S SWEATER

Raye Schwartz

**Finished Size** 40 (50)" bust circumference, lightly blocked. Pullover shown measures 40", modeled with about 7" of ease.

**Yarn** Valley Yarns Valley Superwash (100% extra fine merino; 97 yd [89 m]/50 g); #913 mauve, 18 (22) balls. Yarn distributed by WEBS.

**Needles** Sizes 2 (2.75 mm), 3 (3.25 mm), and 4 (3.5 mm): 36" circulars (cir). Size 2 (2.75 mm): set of double-pointed (dnp). Adjust needle size if necessary to obtain the correct gauge.

**Notions** Markers (m); stitch holders; waste yarn.

**Gauge** 24 sts and 36 rnds = 4" in Cables and Lace chart on size 4 needle lightly blocked; 26 sts and 40 rnds = 4" on size 3 needle.

### NOTES

- Waist is shaped by using progressively smaller, then larger needles.
- The stitches outside the repeat lines on the Cables and Lace chart are there merely to provide a visual reference to assist in keeping in pattern while working shaping.
- When working the chart in the round, read all rounds from right to left; when working back and forth in rows, read odd-numbered rows from right to left and even-numbered rows from left to right.

### Stitch Guide

**Applied I-cord:** With dnp, CO 3 sts.

**Next row:** (RS) \*K2, sl 1 kwise, k1 picked-up st from edge of work, pssso. Do not turn. Slide sts to other end of dnp. Rep from \* until all picked-up sts are worked.

### BODY

With size 2 cir needle, CO 240 (300) sts. Place marker (pm) and join in the rnd.

**Rnd 1:** \*P1, k2, p3, [k3, p4] twice, k3, p3, k2, p2,\* rep from \* to \* 3 (4) more

times, pm for side seam, rep from \* to \* 4 (5) times. Cont in rib patt for 25 more rnds—piece measures about 2½" from CO. Change to size 4 needle and work Rnds 1–20 (21–40) of Cables and Lace chart. **Shape waist:** Change to size 3 needle and work 20 rnds even in patt. Change to size 2 cir needle and work 20 rnds. Change to size 3 needle and work 20 rnds. Change to size 4 needle and work 40 rnds, ending 4 (5) sts before beg-of-rnd m on chart Rnd 40 (20)—piece measures about 15½" from CO. Read all armhole shaping notes before proceeding. **Armhole Shaping Notes: 1.** Armhole shaping charts are not meant to be followed from bottom to top; they show the placement of armhole decs at each side of armhole. **2.** To dec 1 st at armhole, work a single dec without a compensating inc. **3.** A double dec paired with 1 yo will result in 1 st dec'd. **4.** After armhole shaping is complete, incs must be worked with corresponding decs in order for st count to rem consistent. **Divide for armholes:** BO 7 (9) sts, work in patt to 4 (5) sts before m (for front), BO 7 (9) sts, work in patt to end (for back)—9 sts dec'd at each armhole (for size 40", 2 yo's eliminated, for a total of 9 sts dec'd; for size 50", decs before and after BO compensate for 2 yo's of patt); 111 (141) sts rem each for front and back. Place front sts on holder.

### BACK

**Shape armholes:** Work 1 WS row even (as shown in Armhole Shaping chart) then dec 1 st each edge (as shown on Armhole Shaping chart) every RS row 4 times—103 (133) sts rem. Work even in patt, keeping 1 st at each edge in St st, until 70 (80) rows have been worked from beg of arm-

hole shaping—armhole measures about 8 (9)" from dividing row. **Shape shoulders and neck:** (RS) Work 30 (45) sts and place on holder, BO 43 sts for neck, work to end and place rem 30 (45) sts on holder.

### FRONT

Read through instructions before proceeding. **Neck Shaping Notes: 1.** On RS rows, maintain k3, p3 at each neck edge throughout, working these 6 sts in patt on WS rows. **2.** If the patt does not provide the necessary dec at neck edge (see Armhole Shaping Notes), work as foll: (RS) On left-front neck edge, work to last 7 or 8 sts (depending on patt), then p2tog or p3tog, as needed to dec for neck edge in patt, work to end in edge st patt (p2, k3). On right-front neck edge, k3, p2, then p2tog or p3tog, as needed to dec at neck edge, then cont in patt to end. **Divide for front neck:** Place first 55 (70) front sts from holder on size 4 needle, place next st on holder and pm for center-front st, place rem 55 (70) sts on needle. Join yarn, ready to work a WS row, and work armhole shaping as for back. **At the same time,** work first RS row as foll: Work across to 6 sts before m, p3, k3; join 2nd ball of yarn and BO center st, k3, p3, work in patt to end—55 (70) sts rem each side. Working both sides at same time, dec 1 st at each neck and armhole edge every RS row 4 times—47 (62) sts rem each side. Dec 1 st at each neck edge every RS row 9 times—38 (53) sts rem each side. Dec 1 st at each neck edge every 4th row 8 times—30 (45) sts rem each side. Work even until 70 (80) rows have been worked from beg of armhole shaping—armhole should measure about 8 (9)" from dividing row. Place rem sts on separate holders.

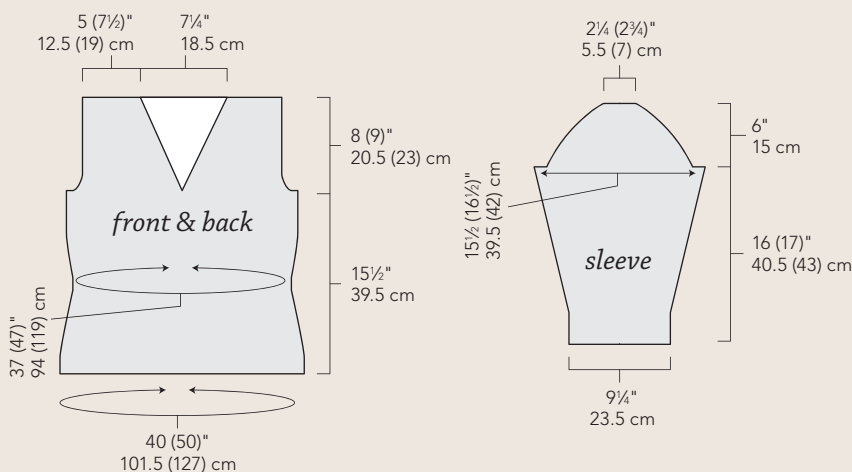

# THE Web-sters



Rowan  
 Araucania  
 Louisa Harding  
 Sublime  
 Louet  
 Lantern Moon  
 Isager Yarns  
 Elsebeth Lavold  
 Habu Textiles  
 Art Yarns  
 Berroco  
 Noro  
 Debbie Bliss  
 Fiesta Yarns  
 Koigu  
 Trendsetter  
 Plymouth  
 Brown Sheep  
 Manos  
 Colinette  
 Prism  
 Classic Elite  
 Mountain Colors  
 Nashua Handknits  
 Brittany Needles  
 Tahki • Stacy Charles  
 Simply Shetland

Rowan  
 Magazine #49  
 \$24.00 plus S&H

Order from our Website  
[www.yarnatwebsters.com](http://www.yarnatwebsters.com)

**THE WEB-STERS**  
 11 N. MAIN STREET  
 ASHLAND, OR 97520  
 1-800-482-9801

## Catch a Breeze



Perfect for layering, dressing up or down, our Claire tee can take you anywhere. The tunic length is up-to-the-minute, and TK's *Summer Breeze* brings fun colors and the crisp feel of linen to this updated classic. Designed by Astrid Tedman for Thomas Kvist Yarns.

shown in shades Pansy/Hawaiian Ocean  
 Pattern sized XS-3X. Purchase at your local yarn shop or online.



Thomas Kvist  
 YARNS

exclusive North  
 American distributor of  
 Thomas Kvist Yarns.

*Summer Breeze*  
 in 9 great colors  
 Stripe it your way.  
 See them all at:

[www.mangomoonyarns.com](http://www.mangomoonyarns.com)



## Halo

Brushed Suri Lace Weight



PT-125 Cascading  
 Leaves Stole



[www.thealpacayarnco.com](http://www.thealpacayarnco.com)  
 1-866-440-PACA(7222)



**MIX IT UP!**  
 Why stop at one color?



**THE DUO & THE QUATRO**  
 100% CASHMERE SCARF KITS

Kits include simple patterns for colorful scarves with 2 or 4 colors. 20 different color combinations available!

WE ARE CASHMERE!

[www.jadesapphire.com](http://www.jadesapphire.com)

- k on RS; p on WS
- p on RS; k on WS
- yo
- / k2tog
- \ ssk
- ⌘ k1tbl on RS; p1tbl on WS
- ▲ sl 2 as if to k2tog, k1, p2sso
- ⋈ sl 1, k2tog, pss0
- ⋈ k3tog
- sl 3 sts onto cn, hold in back, k4, k3 from cn
- bind off 1 st
- center st of adjacent motif each side of armholes; rem of body between armholes not shown
- pattern repeat

### Cables and Lace

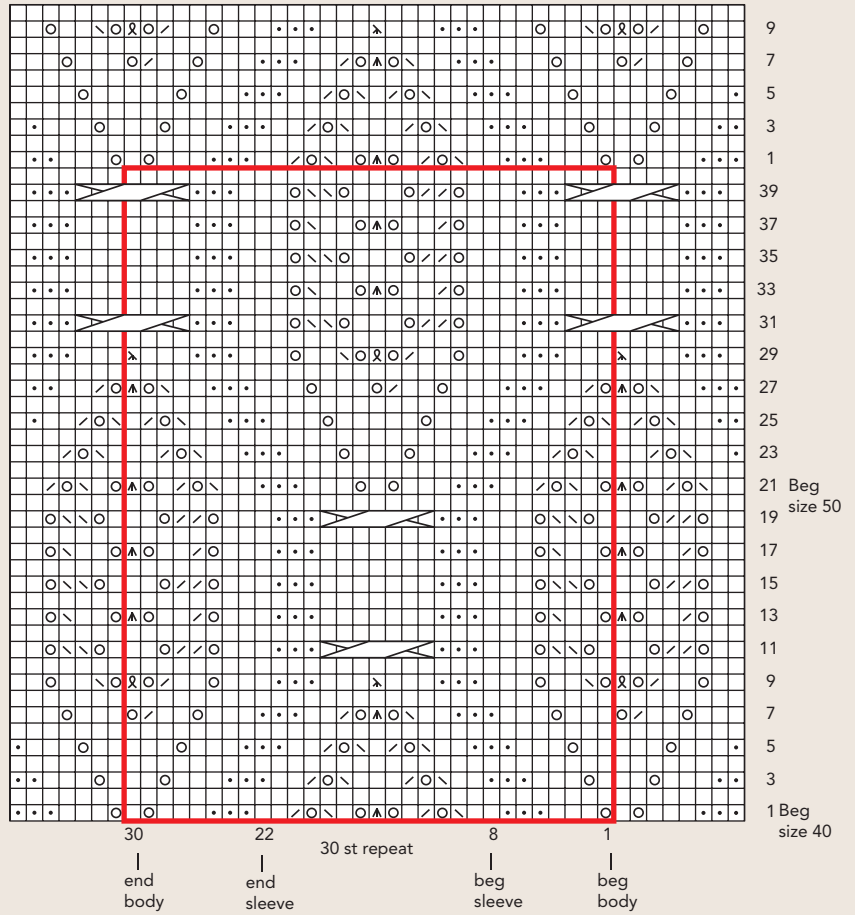

### Armhole Shaping Size 40"

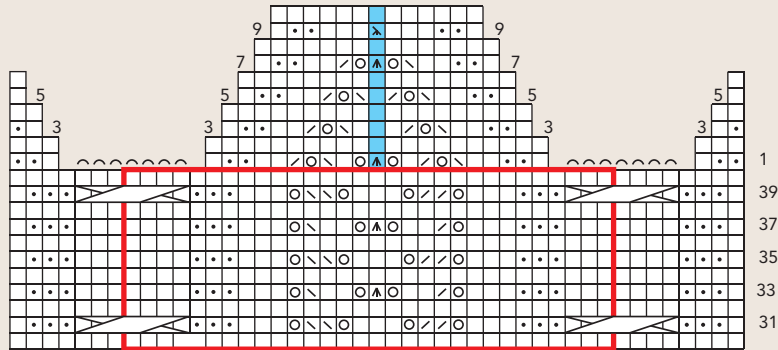

### Armhole Shaping Size 50"

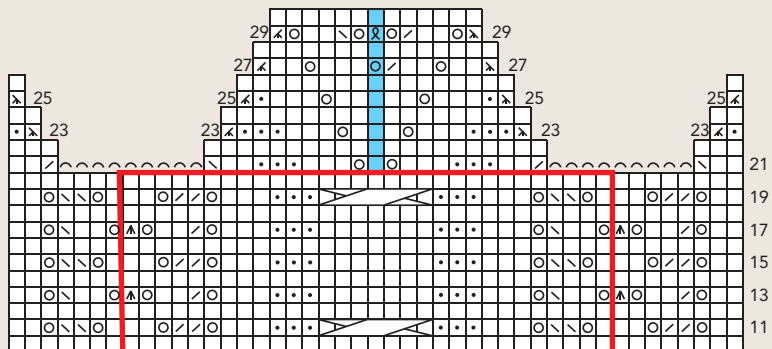

# Strauch Fiber Equipment Co.

We Handcraft It All . . . With You In Mind



Wind your skeins  
into *big,  
beautiful,*  
center pull balls  
with the Strauch  
Jumbo Ball Winder.

Check out our website for our complete line of products and to find a dealer near you:

[www.strauchfiber.com](http://www.strauchfiber.com)

Follow us on Facebook, Twitter & Our Blog on TypePad



Otto & Joanne Strauch • 10319 Johns Creek Road, New Castle, VA 24127  
540-864-8869 • [ors@strauchfiber.com](mailto:ors@strauchfiber.com)

# addi Turbo®

accept no substitutes...



[www.skacelknitting.com](http://www.skacelknitting.com)

## Tilli Tomas

Mystery Skein Shawl  
Now available  
for free download

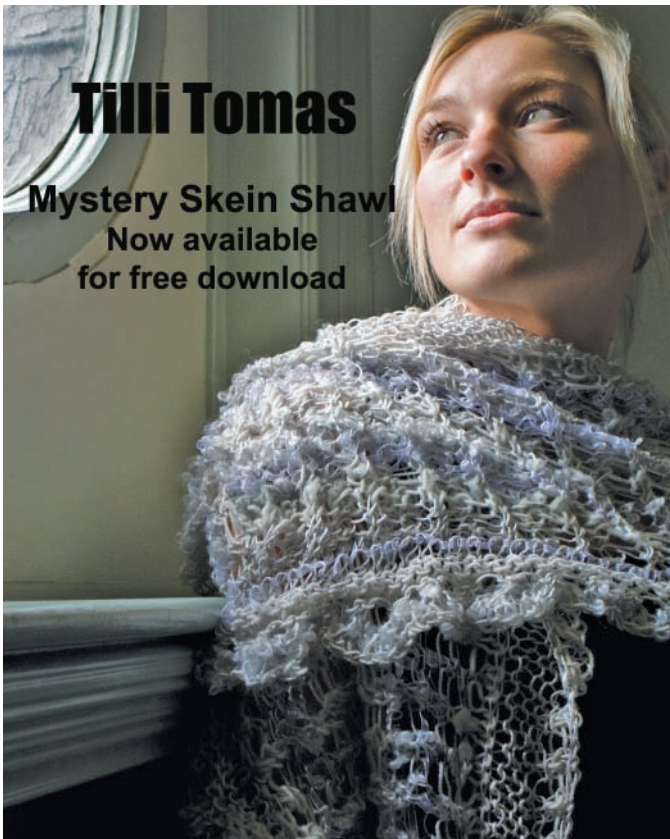

[www.tillitomas.com](http://www.tillitomas.com) 617-524-3330

## THE SANGUINE GRYPHON

romantic new colours  
for spring and an enchanting  
collection of  
art nouveau designs



[WWW.SANGUINEGRYPHON.COM](http://WWW.SANGUINEGRYPHON.COM)

THE YARN KNITTEH  
WITH AMAZING BEAUTY



**Neck edge:** With RS facing and size 2 cir needle, pick up and knit 42 sts across back neck, 52 sts along left-front neck edge, pm for center, M1 st in center BO st, pick up and knit 52 sts along right-front neck—147 sts. Work applied I-cord (see Stitch Guide) around neck edge. Join live sts to CO sts using Kitchener st (see Glossary). Weave in ends. Wash and block sweater.

*Raye Schwartz* lives and knits in New York.



## DROP MESH TEE

Cathy Carron

**Finished Size** 36 (40, 44, 48)" bust circumference. Sweater shown measures 36", modeled with about 3" of ease.

**Yarn** Classic Elite Verde Collection Solstice (70% organic cotton, 30% wool; 100 yd [92 m]/50 g): #2335 pampas, 5 (5, 6, 6) skeins.

**Needles** Size 7 (4.5 mm): 16", 22", and 29" circulars (cir). Adjust needle size if necessary to obtain the correct gauge.

**Notions** Markers (m); tapestry needle.  
**Gauge** 19 sts and 24 rows = 4" in St st.

### NOTES

- Pullover is worked in the round from the top down.
- Attach new skeins of yarn along sleeve or side seams only.
- Mesh pattern is created by dropping stitches and letting them "run." The stitches will not run automatically; they must be helped along. At the bottom of a dropped stitch column, you will need to "capture" the dropped stitch before it ravel into the sleeve. Before beginning, cut four 12" lengths of yarn and set aside; these will be used to secure stitches at sleeve seams while raveling dropped stitches. Work on one sleeve seam at a time as follows: Beginning at the underarm, pick up the dropped stitch at the point where it would start to ravel the sleeve seam, then catch the next stitch going up the seam and tack down with length of yarn. Repeat until all stitches on that seam have been caught. Repeat for other three sleeve seams. Ravel remaining dropped stitches right up through to collar.

### SLEEVES

With dpn, CO 56 sts. Pm and join in the rnd.

**Rnd 1:** K2, p3, pm, k2, [p4, k3] twice, [p3, k2] twice, p3, [k3, p4] twice, k3, pm, p3, k2.

Cont in rib patt for 25 more rnds—piece measures about 2½" from CO. Change to size 4 needle, using magic-loop method.

**Set-up rnd:** K2, p3, sl m, M1 (knit this st every rnd), work Sts 8–30 of Cables and Lace chart once, then work Sts 1–22 once, k1 (knit this st every rnd), sl m, p3, k2—57 sts. Work 3 rnds even. Inc 1 st after first m and before last m on next rnd, then every 4th rnd 17 (21) more times, working inc sts in patt—93 (101) sts. Work even until piece measures 16 (17)" from CO. Beg working back and forth in rows. **Shape cap:** BO 3 sts at beg of next 2 rows. Dec 1 st each side on next RS row, then every other row 2 more times, then every row 12 times, then every RS row 16 times. BO 3 (4) sts at beg of next 4 rows—13 (17) sts rem. BO rem sts.

### FINISHING

Join shoulders using three-needle BO (see Glossary). Sew sleeves into armholes.

### Stitch Guide

**2x2 Rib:** (multiple of 4 sts)

**Rnd 1:** \*K2, p2; rep from \* around. Rep Rnd 1 for patt.

### PULLOVER

**Collar:** With shortest cir needle, CO 72

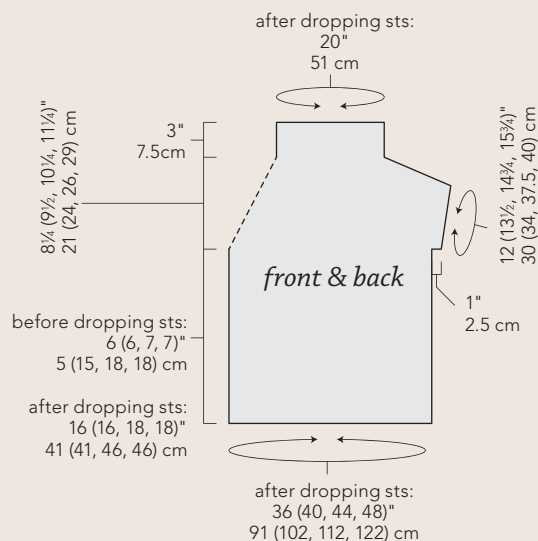



(76, 80, 84) sts. Place marker (pm) and join in the rnd. Work in 2x2 rib (see Stitch Guide) until piece measures 3" from CO.

**Yoke:**

**Rnd 1:** K21 (23, 23, 25) sts for front, pm, k1 (seam st), work in rib as established over 15 (15, 17, 17) sleeve sts, k1 (seam st), pm, k17 (19, 19, 21) sts for back, pm, k1 (seam st), work in rib as established over 15 (15, 17, 17) sleeve sts, k1 (seam st).

**Rnd 2:** (Inc rnd) \*K1, M1, knit to 1 st before next m, M1, k1, sl m, k1, M1, work in rib to 1 st before m, M1, k1, sl m; rep from \* once more—8 sts inc'd.

**Rnd 3:** \*Knit to m, sl m, k1, work in rib to 1 st before m, k1, sl m; rep from \* once more.

Rep last 2 rnds 24 (28, 30, 33) more times, changing to longer cir needles as needed—272 (308, 328, 356) sts; piece should measure about 8¼ (9½, 10¼, 11¼)" from back neck.

**Divide sleeves and body:**

K71 (81, 85, 93) front sts, place 67 (75, 81, 87) sleeve sts on holder, k67 (77, 81, 89) back sts, place 67 (75, 81, 87) sleeve sts on holder—138 (158, 166, 182) sts rem for body. Rejoin to work in the rnd and work even in St st (knit every rnd) until body measures 6 (6, 7, 7)" from underarm. **Beg dropped sts:** \*K1, drop 1 st off needle; rep from \* around (sts will beg to ravel, which is fine, just don't encourage the running until you are ready to pick up the sts along the sleeve seams)—69 (79, 83, 91) sts rem. **Next rnd:** \*K1f&b, M1; rep from \* around—207 (237, 249, 273) sts. BO all sts. Secure sts at sleeves (see Notes). Ravel down the dropped sts. Body should measure about 16 (16, 18, 18)" from underarm after sts have been raveled.

**SLEEVES**

Place 67 (75, 81, 87) sleeve sts on shortest cir needle. Pm and join in the rnd. Work 6 rnds in rib as established. BO all sts in rib.

**FINISHING**

Weave in ends. Sew underarm seams. Check sleeve seam sts to be sure they are all secured (see Notes).

*Cathy Carron* has authored four knitting how-to books, the latest of which is *Cowlgirls: The Neck's Big Thing to Knit* (Sixth&Spring, 2010). An ardent seamless knitter, Cathy keeps looking for the next best shape or idea to explore.



PIECEWORK



Honoring the Rich History of Needlework



6 issues for \$24



pieceworkmagazine.com

PERSONAL THREADS BOUTIQUE

Phone orders received before 12 noon are shipped the same day.

We Stock over 1,000 different yarns in a huge array of colors, including:

- Austermann
- Artful Yarns
- Artyarns
- Berroco/Lang
- Brown Sheep
- Classic Elite
- Colinette
- Crystal Palace
- Dale of Norway
- Debbie Bliss
- Dream In Color
- Filatura Di Crosa
- Fleece Artist / Handmaiden
- Frog Tree
- Grignasco
- Himalaya Yarn Co.
- Jade Sapphire
- K'C<sup>2</sup>
- Koigu Wool
- Lorna's Laces
- Malabrigo
- Mission Falls
- Mountain Colors
- Muench/GGH
- Nashua
- Noro
- O-Wool
- Plymouath
- Prism
- Qiyuk
- Reynolds
- Rowan/Ryc
- Schaefer
- Shokay
- Sirdar
- Skacel
- Stonehedge Fibers
- Tahki/Stacy Charles
- Tilli Tomas
- Trendsetter

To Order: 1-800-306-7733

PERSONAL THREADS BOUTIQUE

Knitting • Needlepoint • Weaving • Quilting  
 Quilting Fabrics: Kaffe Fassett-Martha Negley-Carla Miller-Phillip Jacobs  
 8600 Cass Street • Omaha, Nebraska 68114  
 Fax: 402-391-0039 • e-mail: sales@personalthreads.com  
[www.personalthreads.com](http://www.personalthreads.com)



Help us provide women in Latin America with the ergonomic bench for backstrap weaving

Treasure their art.  
 Value their health!  
 End the pain!

[www.synergioarts.org](http://www.synergioarts.org)  
 (520) 400-1017



Kaori Fujioka



Kaori Fujioka

# In Her Own Words

BETHANY LYTTLE

< Kaori Fujioka's long scarf in progress (above) and off the needles (left).

> Keiko Hayashida's allover-lace shawl, worked carefully for symmetry.



Chizuru Todate



Shirley Paden

**Shirley Paden**, internationally renowned designer and author of *Knitwear Design Workshop* (Interweave, 2010), reflects on her passion for designing and on how teaching others is an integral part of keeping her passion alive. She considers the online design-a-long class that she taught last year on Ravelry ([www.ravelry.com](http://www.ravelry.com)): It allowed students

from three continents, some of whom spoke other languages, to create their own designs from scratch—without ever seeing Shirley in person. Here are her reflections.

I wanted to test my own philosophy, which is that anyone can become a knit-

wear designer with proper guidance, in a new arena. I had developed this philosophy over the years as I taught new knitters in classrooms across the country to design their own patterns. But I found myself wondering whether the same results would be possible online.

So, with help from the moderator of the “We Love Shirley Paden” Ravelry group, Tracy Rivers, and a former student, Mari Tobita, I offered an online design class. It was astounding to see how many students signed up! In addition to students from the United States, some students were from Japan and Australia. Not that any of us really needs more proof, but I certainly saw that the world has gone from being a beach ball to a golf ball! All these knitters from different parts of the world and different time zones, some of whom did not speak English or own my book, signed up, joined hands with each other, and created a virtual community of budding designers.

Everything had to be planned very carefully. After all, we were managing different time zones (more than once, I set the alarm for strange hours to conduct the class). Mari served as interpreter for the

Japanese-speaking students. I worked with each student one-on-one during the prep for the class and during the first few weeks. After the initial period, I guided students back to the online community because I find that students do best when they watch each other learn; it exposes them to a broader range of questions and techniques.

Things were set up so that each student could start with a design idea, layer on a pattern stitch, create a swatch, use it in relation to personal measurements, and then knit up, referring to the worksheets. We took the process one step at a time. There were starts and stops, reversals, and discussions. But slowly something beautiful evolved. Today, when I look at photos of the garments that these far-flung students of mine created, I feel nothing short of awe.

People wonder how different my approach to teaching had to be because it was online. Well, it was actually a lot less different than you might think. Although I couldn't reach out and touch the students' yarn or guide them with my voice, I could post corrections for the students on the screen and offer as much hand-holding as necessary. What I saw happen was that





< Bonnie Sennott's lace panel pullover, in progress (below) and off the needles (left).  
 > Yuri Nagoaka's allover-lace pullover.



the students began to really engage with each other. They became inspired by one another's swatches, for instance, and suddenly the posts would appear: "What yarn are you using?" or "That's beautiful!" There was a snowball effect as each person got excited about the work that the others were doing. I just loved that!

Along the way, as steps were completed, you'd see a post appear: "Ready to knit." Then another: "Ready to knit." There was a rhythm to it, a building up of excitement and togetherness, even though we couldn't literally hear the others' voices. When the class ended, my eyes filled with tears because I could look back and remember when a certain student had to rip out a few rows or another had to overcome some mathematical hurdle. The experience of seeing disparate knitters grow into designers was quite moving to me.

In part, I think that my emotions come from the fact that I identify with their process. People often think designing is easy for me, that I zip along without my own frustrations and disappointments. But as I always say to my students, "When it

comes to knitting a design that you've created, there's only one thing you can count on: Something is going to go wrong!" All the careful planning in the world won't prevent those moments when you put needle to yarn and discover that you've not taken a certain variable into account or haven't looked at a detail from a particular perspective. In fact, to this day, even with all my experience (I've been knitting since I was about nine years old, have taught countless design classes, have my own custom design business), no project goes forward without a hitch. That's why at the beginning of any design class, I always laugh before we start and say, "Let's pray!"

But what I've come to realize is that encountering challenges is the best part of the knitwear design experience. Suddenly you're doing more than reading a chart or a series of instructions. You're interacting with your own vision, pulling it out of some sort of abstract universe and making it real, making it become what you'd hoped for all along. The mistakes that get made when you're designing are different than the mistakes you make when you overlook a row on

a published chart or when you drop a stitch. The mistakes you make when you're working up your own creation add to what I call "design wisdom." Somehow the mistakes really stay with you and get incorporated into your "knitting brain"! The next time you begin a project, those skills are at the ready.

In the end, the challenges keep me engaged. I love the excitement, rhythm, and movement of pattern stitches and the mental acuity necessary to get them to come together in a way that flatters the body. I come to designing from a fashion point of view, not a knitting point of view. I think about the outcome—a lot! But that's what allows me—and any knitter who wants to design his or her own garments—to knit and really see! Designing lets you transcend the "task" of knitting and turn it into an interactive experience.

And for me, the challenges are where I find energy and inspiration to keep going. I love to try new things. I'm always wondering about new approaches to tailoring, shaping, and teaching. I'm always trying to see what else the knit stitch can do. I'm not one of those knitters who takes one



Yumiko Alexander

< Yumiko Alexander's swiny allover-lace vest.

> Natascha Davis's lace-trimmed empire-waist pullover, in progress (below) and finished (right).



Kenneth Davis



Kenneth Davis

technique and then gets really good in that area. I'm not an expert on one thing. I prefer to cross lines, ask new questions, and try things in new ways.

Teaching and learning are how I stay energized and inspired. I like to say that it takes a design class to write a book. And the reason is that as I teach a class, students weigh in. Maybe they say that they don't understand what I'm trying to tell them. Or maybe they ask why a certain technique can't be done a different way. I try to incorporate their talents and approaches into my own. Teaching, whether online or in person, is the way that *I* grow. It's far from a one-sided, top-down experience!

Another way I stay inspired is by attending any and all textile exhibits! These don't have to be about knitting. They can be about weaving, fashion design, you name it. If there's a show on, I'm there with my notebook! I don't care how tired I am or where I am on the globe. Because the only possible way you can ever become bored with your work or with your life is by assuming that you've learned all there is to know. I'm always on the hunt for something new to learn.

In fact, I'm learning on such a consistent

basis, that my brain can't always contain it all! Sometimes I'll look over one of my older designs and think: "How did I do that?" I'll have no idea how I figured it out! And sometimes people will ask me questions about garments that I designed about four hundred patterns ago. When I go back to find the answer, I find myself learning right alongside the person who asked me the question!

And this is exactly how students learn, too. They follow my lead, yes, and they learn to work with an eye to color, cables, lace, texture, and fit, but they do it with their unique creativity and only two basic stitches—knit and purl! Something about that is so miraculous. There are so many permutations. I haven't seen them all, and I don't expect to see them all in my lifetime. And it's not just that the options are endless—design and fashion are always evolving, too. You can take a lace pattern from, say, the 1900s and lay it over a garment shape that's very 2011, and you won't just get a pretty garment, you'll get a new set of challenges. How do you develop stitching and measuring and detail that will accommodate the design, take into account how people wear clothes today, and satisfy what they want from their gar-

ments? These are questions that anyone can answer. It's just a matter of gathering with other students as you try.

You might think that designing must be for other people, not you. But never let my—or anyone else's—references to math or details or process intimidate you! It's a one-step-at-a-time experience, and it all makes sense as you go along. Just ask my online design students. Or better yet, take a look at their garments! To this day, when I look at a scarf or sweater designed by an online student in Japan or Australia and recall how students from around the world posted comments, encouragement, and questions, I'm amazed. I'm startled that this miracle is possible. So, if you wonder how I design or why I keep wanting to design, you have the answer. To watch the process of a vision unfold, take form, and live in the world—something unique to the knitter who creates it—is awe-inspiring. Why would I want to do anything else? ■

—As told to Bethany Lyttle

**Bethany Lyttle** is a freelance writer who lives in New York City.



2nd Annual  
**Kentucky  
 Sheep and Fiber  
 Festival**

A natural fiber, local food event in conjunction with



**The Bluegrass Classic  
 Stockdog Trial**

**PARKS  
 & RECREATION  
 LEXINGTON, KY**

Workshops: May 20-22, 2011  
 Festival: May 21-22, 2011



[www.KentuckySheepAndFiber.com](http://www.KentuckySheepAndFiber.com)  
 Proceeds benefit Kentucky 4-H & FFA

*indulge*  
 your passion for knitting

Vermont's Best Yarn Shop  
 Shipping thousands of orders worldwide

kaleidoscope  
**YARNS**®

[ SHOP ONLINE ] [www.kyarns.com](http://www.kyarns.com)

US shipping just \$4.95! **FREE SHIPPING** on orders over \$75!

Sign up for exclusive savings! [kyarns.com/newsletter](http://kyarns.com/newsletter)

TRY  
 OUR  
 NEW  
 SOLID  
 COLOR  
 SERIES



The Loopy Ewe  
[theloopyewe.com](http://theloopyewe.com)  
 (888) 527-9181

Fast Shipping and  
 Frequent Shopper  
 Benefits

**90 COLORS**



LORNA'S  
*Laces*  
 HAND-DYED-YARNS  
 We make pretty string.  
[www.lornalaces.net](http://www.lornalaces.net)

A woman with dark hair is wearing a short-sleeved, crew-neck knit top. The top is made of a textured yarn and features a pattern of interlocking, slightly irregular rectangular shapes in shades of purple, blue, and green. The pattern is dense and covers the entire front of the top. The woman is looking slightly to the right of the camera with a gentle smile. The background is a softly blurred indoor setting, possibly a bedroom, with a bed and a lamp visible.

**BONNIE PAUL'S CURVY SQUARES TEE**

is a departure from traditional entrelac: tiers of squares that grow and shrink in size stack up into a neatly fitted yoke and a flattering built-in shape. **PAGE 80. YARN** Plymouth Yarn Mushishi

*entrelac*

woven-look knitting worked in connected rectangles

Designed with standardized units or dimensions, as for easy assembly and repair or flexible arrangement and use.

# mod\*u\*lar

*adj.*

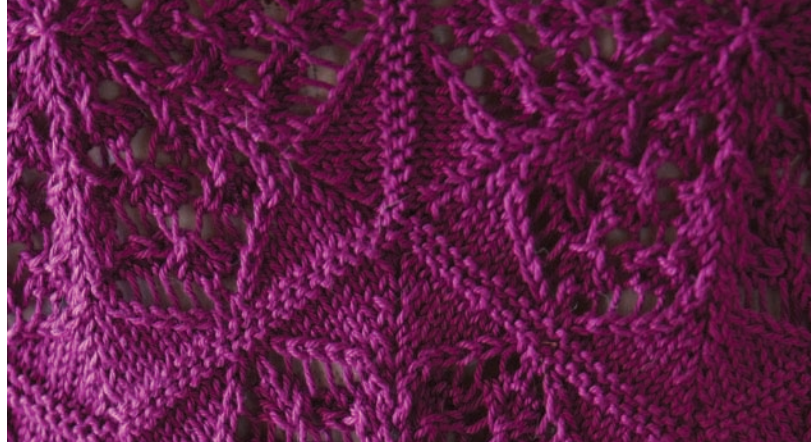

Taking a cue from knitted and crocheted doilies, **MARIA LEIGH** builds the **HEXAGON PETAL TEE** out of eighteen connected panels. A simple lace motif blooms into an intricate adornment when repeated six times within each hexagon. **PAGE 83. YARN** Cascade Ultra Pima



*pure modular knitting*  
tessellated units fit together without gaps



mod\*u\*lar



*entrelac  
in three dimensions*  
extra units create shape

The **DIMINISHING GORE SKIRT** hides extra squares in a standard entrelac structure to create a pleated gusset—four gores result in a flowing A-line shape and a jagged handkerchief edge. **GWEN BORTNER, PAGE 88. YARN** Green Mountain Spinnery Cotton Comfort

The **PINKERTON SHAWL** stacks two triangles for an asymmetrical wrap with pleasing angles. Working in two directions and in two different stitches, **SUSAN DITTRICH** creates striking graphic contrast with simple stitches and short-rows. **PAGE 90. YARN** Hazel Knits Artisan Sock







*directional knitting* join as you go

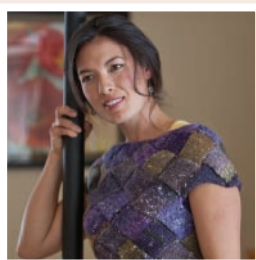

## CURVY SQUARES TEE

Bonnie Paul

**Finished Size** 31½ (35, 39, 43, 46½, 50½)" bust circumference, slightly stretched. Sweater shown measures 35".

**Yarn** Plymouth Yarn Mushishi (95% wool, 5% silk; 491 yd [449 m]/250 g): #10 purple/olive, 2 (2, 3, 3, 3, 4) skeins.

**Needles** Size 8 (5 mm); 24" circular (cir). Adjust needle size if necessary to obtain the correct gauge.

**Notions** Stitch holders; tapestry needle.

**Gauge** 16 sts and 20 rows = 4" in St st.

### NOTES

- Sweater is knit from the top down in one piece as entrelac in-the-round. For more details about this technique, download Eunny Jang's tutorial at [knittingdaily.com/media/p/24512.aspx](http://knittingdaily.com/media/p/24512.aspx).
- In entrelac, the edges are often slipped on the joining edge. In this design, we work all edge stitches, which yields better stretch in the fabric.
- When picking up stitches, there will be fewer holes in the fabric if you pick up stitches as close to the corner as possible.
- Change skeins/colors at the beginning of a square/triangle to avoid abrupt color changes in the middle of the square/triangle.
- After each square is finished, place stitches on holder. Transfer stitches back to left needle as they are needed.

### UPPER BODY

With the invisible provisional method (see Glossary), CO 70 (80, 90, 100, 110, 120) sts loosely. Do not join. **Note:** This CO edge becomes the long (bias) edge of the first row of triangles and will need to stretch quite a bit. Since it is a provisional CO and you will replace it later, it's better to err slightly on the side of too loose, rather than too tight. Also, using waste yarn in a contrasting color (but similar

gauge) will make it easier to identify and remove provisional sts when you are finishing.

**Neck-edge triangles:** (10 triangles of 7 [8, 9, 10, 11, 12] sts each)

**Triangle 1:**

**Row 1:** (WS) P2, turn.

**Row 2 and all RS rows:** Knit to end of triangle, turn.

**Row 3:** P3, turn.

**Row 5:** P4, turn.

Cont in patt, adding 1 st to triangle every WS row until 7 (8, 9, 10, 11, 12) sts have been worked. **Next row:** (RS) Knit to end of triangle, turn. **Next row:** P7 (8, 9, 10, 11, 12); do not turn. Place sts on holder.

### Triangles 2–10:

Work as for Triangle 1. On last triangle, do not place sts on holder. Join triangles at CO edge to form circle (being careful to not twist sts) on first tier as foll (**Note:** Change direction of knitting at each new tier of squares or triangles throughout):

**First tier:** (10 squares of 8 [9, 10, 11, 12, 13] sts each)

**Square 1:** (WS) Pick up and purl 8 (9, 10, 11, 12, 13) sts along edge of first triangle.

**Row 1:** (RS) K7 (8, 9, 10, 11, 12) sts, ssk (last st of square and first st of triangle), turn.

**Row 2:** Purl to end of square, turn.

Rep Rows 1 and 2 until all sts of triangle

### Underarm Triangle Placement Guide

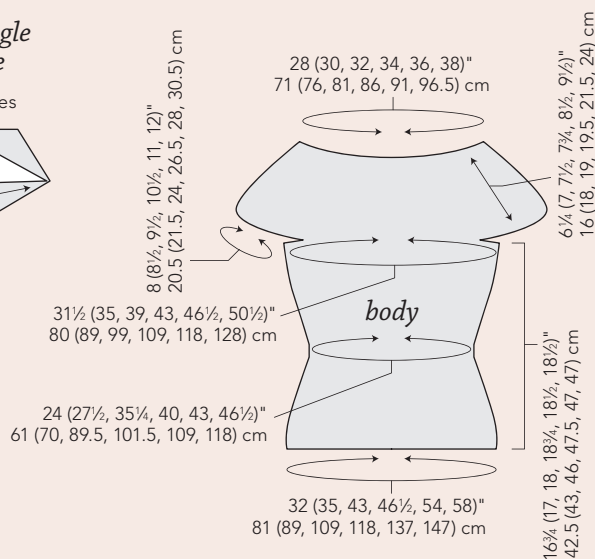
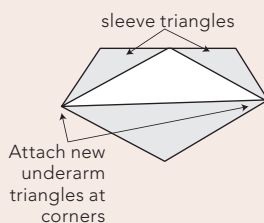



Where life meets knitting

Visit your online community for all things knitting.

With your membership to the KnittingDaily.com you'll receive:

- Free daily e-newsletters
- Free tips and technique tutorials
- Free sale alerts at interweavestore.com
- Free access to forums and blogs



Plus! KnittingDaily.com has a  
HUGE FREE PATTERN LIBRARY



Have a question about your  
Interweave Knits subscription?

We have  
the answer!

Visit our website,  
email, or call, and we'll  
be happy to assist you.  
Go to [interweaveknits.com](http://interweaveknits.com) and click  
on customer service for new subscriptions,  
renewals, gift orders, or to change your address.

For questions or concerns with your  
subscription, contact us at:

Email address: [interweaveknits@pcspublink.com](mailto:interweaveknits@pcspublink.com)

U.S. Customer Service: (800) 835-6187

U.S. Mail: PO Box 469117, Escondido, CA 92046-9117

ChiaoGoo

Stainless Steel ~ Beyond Bamboo

INTRODUCING  
NEW STAINLESS STEEL

PREMIUM RED LACE CIRCULARS

SIZES 0 (2 MM) – 11 (8 MM),  
UP TO 60"

~ SMOOTH JOINS, PRECISELY  
MACHINED AND TAPERED LACE TIPS

PREMIUM 6" DOUBLE POINTS

SIZES 0 (2 MM) – 11 (8 MM)

~ SMOOTH SATIN FINISH,  
LIGHTWEIGHT, 100% RECYCLABLE



have been worked, ending with a RS row. Do not turn. Place sts on holder.

**Square 2:** (RS) \*Pick up and knit 8 (9, 10, 11, 12, 13) sts along edge of next triangle, turn.

**Row 1:** (WS) Purl to end of square, turn.

**Row 2:** K7 (8, 9, 10, 11, 12), ssk (last st of square and first st of triangle), turn.

Rep Rows 1 and 2 until all sts of triangle have been worked. Do not turn. Place sts on holder. Rep from \* for Squares 3–10. On last square, do not place sts on holder.

**2nd tier:** (10 squares of 9 [10, 11, 12, 13, 14] sts each)

**Square 1:** (RS) Pick up and knit 9 (10, 11, 12, 13, 14) sts along edge of first square from previous tier.

**Row 1:** (WS) P8 (9, 10, 11, 12, 13), p2tog (last st of square and first st of square from previous tier), turn.

**Row 2:** Knit to end of square, turn.

Rep Rows 1 and 2 until all sts of square from previous tier have been worked, ending with a WS row. Do not turn. Place sts on holder.

**Square 2:** (WS) \*Pick up and purl 9 (10, 11, 12, 13, 14) sts along edge of square from previous tier.

**Row 1:** (RS) Knit to end of square, turn.

**Row 2:** P8 (9, 10, 11, 12, 13), p2tog (last st of square and first st of square from previous tier), turn.

Rep Rows 1 and 2 until all sts of square from previous tier have been worked. Do not turn. Place sts on holder. Rep from \* for Squares 3–10. On last square, do not place sts on holder.

**3rd tier:** (10 squares of 10 [11, 12, 13, 14, 15] sts each)

**Square 1:** (WS) Pick up and purl 10 (11, 12, 13, 14, 15) sts along edge of first square from previous tier.

**Row 1:** (RS) K9 (10, 11, 12, 13, 14), ssk (last st of square and first st of square from previous tier), turn.

**Row 2:** Purl to end of square, turn.

Rep Rows 1 and 2 until all sts of square from previous tier have been worked, ending with a RS row. Do not turn. Place sts on holder.

**Square 2:** (RS) \*Pick up and knit 10 (11, 12, 13, 14, 15) sts along edge of square from previous tier.

**Row 1:** (WS) Purl to end of square, turn.

**Row 2:** K9 (10, 11, 12, 13, 14), ssk (last st of square and first st of square from previous tier), turn.

Rep Rows 1 and 2 until all sts of square

from previous tier have been worked. Do not turn. Place sts on holder. Rep from \* for Squares 3–10. On last square, do not place sts on holder.

#### 4th tier and triangles for sleeves:

On this row, you will be ending cap sleeves with triangles and adding underarm triangles.

**Square 1:** (RS) Pick up and knit 9 (10, 11, 12, 13, 14) sts along edge of first square from previous tier.

**Row 1:** (WS) P8 (9, 10, 11, 12, 13), p2tog (last st of square and first st of square from previous tier), turn.

**Row 2:** Knit to end of square, turn.

Rep Rows 1 and 2 until all sts of square from previous row have been worked, ending with a WS tier. Do not turn. Place sts on holder.

#### Sleeve Triangle 1:

(WS) Pick up and purl 9 (10, 11, 12, 13, 14) sts along edge of next square from previous tier.

**Row 1:** (RS) Knit to end of triangle, turn.

**Row 2:** Purl to last st of triangle, p2tog (last st of triangle and first st of square from previous tier), turn.

**Row 3:** Rep Row 1.

**Row 4:** Rep Row 2.

**Row 5:** Knit to last 2 sts, ssk, turn.

Rep Rows 4 and 5 until 2 sts rem. P2tog; do not turn.

**Sleeve Triangle 2:** Pick up and purl 8 (9, 10, 11, 12, 13) sts. Work as for Triangle 1.

**Square 2:** Pick up and purl 8 (9, 10, 11, 12, 13) sts. Work as for Square 2 of 2nd tier.

**Squares 3 and 4:** Pick up and purl 9 (10, 11, 12, 13, 14) sts. Work as Square 2.

**Sleeve Triangles 3 and 4:** Work as for Sleeve Triangles 1 and 2.

**Squares 5 and 6:** Work as for Squares 2 and 3. On last square, do not place sts on holder.

#### UNDERARM TRIANGLES (MAKE 2, ONE FOR EACH UNDERARM)

\*With a new skein of yarn and the provisional method, CO 9 (10, 11, 12, 13, 14) sts loosely. Make a triangle as for beginning neck triangles as foll:

##### Triangle 1:

**Row 1:** (WS) P2, turn.

**Row 2 and all RS rows:** Knit to end of triangle, turn.

**Row 3:** P3, turn.

**Row 5:** P4, turn.

Cont in patt, adding 1 st to triangle every WS row until 9 (10, 11, 12, 13, 14) sts

have been worked. **Next row:** Knit to end of triangle, turn. **Next row:** P9 (10, 11, 12, 13, 14), do not turn. Place sts on holder. Fasten off. Rep from \* for opposite underarm triangle. Attach to outside corners of cap sleeve triangles as shown (see Underarm Triangle Placement Guide). This will provide continuity when you cont the body in the next tier of squares.

#### BODY

Cont in rnds and shape body as foll:

**5th tier:** (8 squares)

**Square 1:** Pick up and purl 9 (10, 11, 12, 13, 14) sts. Work as for 3rd tier.

**6th tier:**

**Square 1:** Pick up and knit 9 (10, 11, 12, 13, 14) sts. Work as for 2nd tier.

**7th tier:**

**Square 1:** Pick up and purl 8 (9, 10, 11, 12, 13) sts. Work as for 3rd tier.

**8th tier:**

**Square 1:** Pick up and knit 8 (8, 10, 11, 12, 14) sts. Work as for 2nd tier.

**9th tier:**

**Square 1:** Pick up and purl 7 (8, 10, 12, 13, 15) sts. Work as for 3rd tier.

**10th tier:**

**Square 1:** Pick up and knit 7 (9, 11, 12, 14, 16) sts. Work as for 2nd tier.

**Sizes 31½ (35, 39, 43, 46½)" only:**

**11th tier:**

**Square 1:** Pick up and purl 8 (10, 11, 13, 15) sts. Work as for 3rd tier.

**Sizes 31½ (35, 39, 43)" only:**

**12th tier:**

**Square 1:** Pick up and knit 9 (10, 12, 13) sts. Work as for 2nd tier.

**Sizes 31½ (35, 39)" only:**

**13th tier:**

**Square 1:** Pick up and purl 9 (10, 12) sts. Work as for 3rd tier.

**Size 31½" only:**

**14th tier:**

**Square 1:** Pick up and knit 9 sts. Work as for 2nd tier.

#### END TRIANGLES

**Sizes 35 (39, 46½)" only:** Pick up and knit 10 (12, 15) sts along edge of first square from previous tier.

##### Triangle 1:

**Row 1:** (WS) Purl to last st of triangle, p2tog (last st of triangle and first st of square from previous tier), turn.

**Row 2:** Knit to end of triangle, turn.

**Row 3:** Rep Row 1.

**Row 4:** Knit to last 2 sts, ssk, turn.

Rep Rows 3 and 4 until 3 sts rem. P3tog; do not turn.

**Triangle 2:** (WS) \*Pick up and purl 9 (11, 14) sts along next square from previous tier.

**Row 1:** (RS) Knit to end of triangle, turn.

**Row 2:** Purl to last st of triangle, p2tog (last st of triangle and first st of square from previous tier), turn.

**Row 3:** Rep Row 1.

**Row 4:** Rep Row 2.

**Row 5:** Knit to last 2 sts, ssk, turn.

Rep Rows 4 and 5 until 3 sts rem. P3tog; do not turn. Rep from \* for Triangles 3–8. On last triangle, BO rem st.

**Sizes 31½ (43, 50½)" only:** Pick up and purl 9 (13, 16) sts along edge of first square from previous tier.

**Triangle 1:**

**Row 1:** (RS) Knit to last st of triangle, ssk (last st of triangle and first st of square from previous tier), turn.

**Row 2:** Purl to end of triangle, turn.

**Row 3:** Rep Row 1.

**Row 4:** Purl to last 2 sts, p2tog, turn.

Rep Rows 3 and 4 until 3 sts rem. Sssk; do not turn.

**Triangle 2:** \*Pick up and knit 8 (12, 15) sts along edge of square from previous tier.

**Row 1:** (WS) Purl to end of triangle, turn.

**Row 2:** Knit to last st of triangle, ssk (last st of triangle and first st of square from previous tier), turn.

**Row 3:** Rep Row 1.

**Row 4:** Rep Row 2.

**Row 5:** Purl to last 2 sts, p2tog, turn.

Rep Rows 4 and 5 until 3 sts rem. Sssk; do not turn. Rep from \* for Triangles 3–8. On last triangle, BO rem st.

### FINISHING

Weave in ends. Block to dimensions.

**Neck:** Remove provisional CO and transfer live sts to needle. Do not join. Join new yarn, taking care to match color as closely as possible. With RS facing, BO all sts. **Note:** Neckline dimension can be adjusted slightly depending on how loosely or tightly you BO. Rep for underarm sts. Weave in ends. Block again, if desired.

*Bonnie Paul* began to crochet and knit as a much-needed respite while completing her doctoral work in psychology. Her focus as a knitwear designer is creating elegant, wearable art; she blogs about knitting and crochet as inspiration for personal growth at [www.consciousknitter.wordpress.com](http://www.consciousknitter.wordpress.com).



## HEXAGON PETAL TEE

Maria Leigh

**Finished Size** 37½ (40½, 43½)" bust circumference. Sweater shown measures 37½".

**Yarn** Cascade Ultra Pima (100% pima cotton; 220 yd [201 m]/100 g): #3703 raspberry, 4 (5, 5) skeins.

**Needles** Size 6 (4 mm): 16" and 24" circular (cir) and set of 4 double-pointed (dpn).

Adjust needle size if necessary to obtain the correct gauge.

**Notions** Markers (m); removable markers; tapestry needle.

**Gauge** 20 sts and 26 rows = 4" in St st; hexagon with 21 (23, 25) sts along each side measures 6¼ (6¾, 7¼)" wide from center-of-side to center-of-side, and 7¼ (8, 8½)" from point to point.

### NOTES

- This tee is constructed from individual hexagon motifs, beginning with Hexagon 1 and ending with Hexagon 18 (for deeper armholes) or Hexagon 20 (for shallower armholes). Each successive hexagon is joined to the preceding hexagon, following the Joining Diagram.
- The yarn amounts given are sufficient for either armhole depth for all sizes.
- If there are too many stitches at the start of a motif to fit comfortably

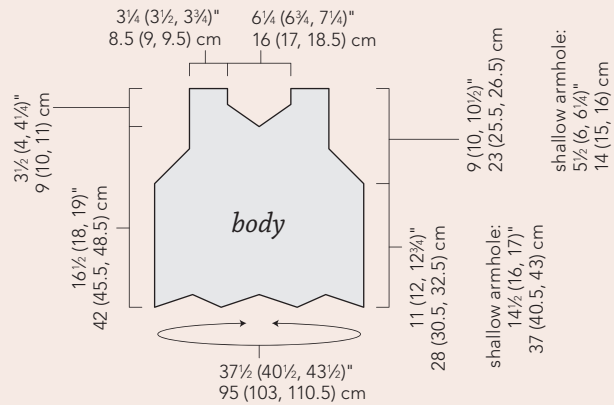

### Joining Diagram

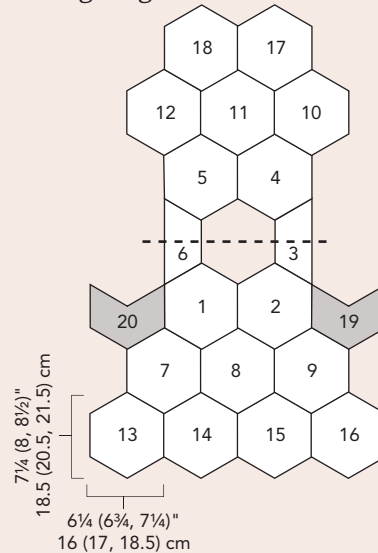

on the double-pointed needles, begin the hexagon using the shorter circular needle and mark each 21 (23, 25)-stitch section on the needle. Change to double-pointed needles as necessary, placing two sections on each needle.

- Hexagon chart is worked both in rounds and back and forth in rows. Hexagons 3, 6, 19, and 20 are partial motifs worked in rows with selvedge stitches at each side.
- To adjust finished size, work smaller or larger hexagons by changing needle size. Hexagons measuring 6 (6½, 7)" wide from center-of-side to center-of-side will produce bust sizes of 36 (39, 42)", and hexagons measuring 6½ (7, 7½)" will produce bust sizes of 39 (42, 45)". Altering hexagon size will also affect the length of the garment.

**Stitch Guide**

**Picot BO:** BO 3 sts, \*sl rem st on right needle back to left needle, use the cable method (see Glossary) to CO 2 sts, BO 5 sts; rep from \* until 1 st rem, fasten off last st.

**BODY**

**Hexagon 1**

With dpn and using long-tail method (see Glossary), CO 126 (138, 150) sts. Divide sts evenly on 3 dpn, 42 (46, 50) sts each needle, and join in the rnd. Place removable marker in center of each needle—21 (23, 25) sts each in 6 sections. Beg with Rnd 5 (3, 1), work Hexagon chart through Rnd 25—6 sts rem. Remove markers, break yarn and draw tail through all sts, pulling snugly to close hole in center of hexagon. Weave in ends.

**Hexagon 2**

With dpn and using long-tail method, CO 42 (46, 50) sts for first two sides of hexagon. With RS facing and picking up sts using main yarn and CO tail alternately, pick up and knit 21 (23, 25) sts from one edge of Hexagon 1 for 3rd side, as shown in joining diagram, then cont with same CO tail and main yarn, CO 63 (69, 75) sts for rem 3 sides—126 (138, 150) sts. Divide sts evenly on 3 dpn, 42 (46, 50) sts each needle, join in the rnd, and place removable markers in center of each needle—21 (23, 25) sts each in 6 sections. Work Hexagon chart as for Hexagon 1—6 sts rem. Close hole in center and weave in ends as for Hexagon 1.

**Tech Tip**

Weave in ends as you go to avoid facing dozens of tails during finishing. Try picking up alternate stitches for a new motif with the working yarn and the tail of the base motif.



- k on RS and all rnds; p on WS
- p on RS and all rnds; k on WS
- yo
- k2tog on RS and all rnds; p2tog on WS
- ssk on RS and all rnds; ssp on WS
- k3tog on RS and all rnds; p3tog on WS
- sl 2 as if to k2tog, k1, pass 2 slipped sts over
- p2tog for size 43½"; p1 for size 40½"
- ssp for size 43½"; p1 for size 40½"
- p2tog for sizes 40½" and 43½"; p1 for size 37½"
- ssp for sizes 40½" and 43½"; p1 for size 37½"

Hexagon

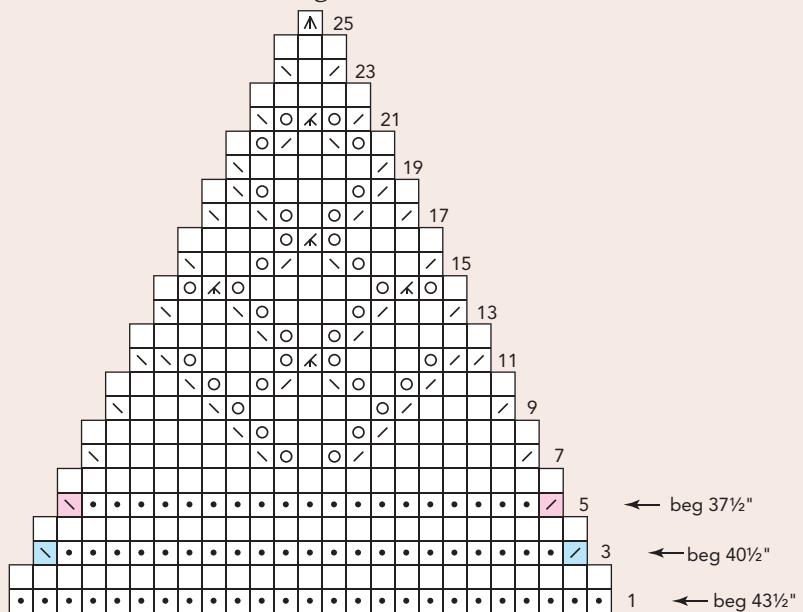

# Spin Knit

Fiber, needles,  
spindle, wheel

Experience a world of fiber firsthand with *SpinKnit*, our new dynamic digital eMag. It's beautiful, immersive, and packed with experiences that make reading more fun than ever.



Imagine a magazine that takes you there: learn spinning in the Peruvian highlands, experience how twist energy shapes a garment, or visit an alpaca farm to see an ultra-luxurious new fiber on the hoof. Kaye Collins, Kathryn Alexander, Judith MacKenzie, Priscilla Gibson-Roberts and other artists who have shaped our craft are all waiting to meet you through *SpinKnit*. Learn from them, then hone your skills with beautiful and challenging patterns. *SpinKnit* brings the world of fiber to you. Now, don't just read about it — be there!

Intuitive navigation lets you effortlessly explore each issue through:

Video tours and interviews

Slide shows that allow you to zoom in at microscopic levels

Downloadable knitting patterns that are easy to print and take with you

Web resources to help you dig even deeper

*SpinKnit* expands the horizons of handspinning—a fusion of the ancient craft of handspinning with the very cutting edge of digital technology. The experience is nothing short of magical.

 **INTERWEAVE**<sup>™</sup>  
interweavestore.com

**866-949-1646**

**Hexagon 3 (partial hexagon)**

With dpn and using long-tail method, CO 1 st (selvage st), place marker (pm). With RS facing and using main yarn and CO tail alternately, pick up and knit 21 (23, 25) sts from one edge of Hexagon 2 for first side, as shown in diagram, pm, CO 21 (23, 25) sts for 2nd side (neck edge), pm, CO 21 (23, 25) sts for 3rd side, pm, CO 1 st (selvage st)—65 (71, 77) sts; 21 (23, 25) sts each in 3 sections, 1 selvage st each side. Beg with Row 5 (3, 1), work Hexagon chart back and forth in rows, knitting selvage sts every row, through Row 25—5 sts rem. Remove markers, break yarn, draw tail through all sts, and pull snugly. Weave in ends.

**Hexagon 4**

Work as for Hexagon 2, picking up 21 (23, 25) sts for 3rd side from Hexagon 3, as shown in diagram.

**Hexagon 5**

Work as for Hexagon 2, picking up 21 (23, 25) sts for 3rd side from Hexagon 4, as shown in diagram.

**Hexagon 6 (partial hexagon)**

With dpn and using long-tail method, CO 1 st (selvage st), pm. With RS facing and using main yarn and CO tail alternately, pick up and knit 21 (23, 25) sts from one edge of Hexagon 5 for first side, pm, CO 21 (23, 25) sts for 2nd side (neck edge), pm, then pick up and knit 21 (23, 25) sts from Hexagon 1 for 3rd side, CO 1 st (selvage st)—65 (71, 77) sts; 21 (23, 25) sts each in 3 sections, 1 selvage st each side. Complete as for Hexagon 3.

**Hexagons 7–18**

Working the hexagons in order according to the joining diagram, either CO 21 (23, 25) sts or pick up and knit 21 (23, 25) sts from adjacent hexagons for each side—126 (138, 150) sts for each hexagon.

**Note:** Diagram shows body opened out flat for clarity, but each row of hexagons should be worked all the way around the body to form a cylinder. For example, after completing Hexagon 9, pick up sts for Hexagon 10 from Hexagons 9 and 4; for Hexagon 12, pick up sts from Hexagons 7 and 5 to complete the cylinder.

**For shallower armholes only:****Hexagon 19 (partial hexagon)**

With dpn and using long-tail method, CO 1 st (selvage st), pm, then using

main yarn and CO tail alternately, pick up and knit 21 (23, 25) sts from Hexagon 4 for first side, pm, 21 (23, 25) sts from Hexagon 10 for 2nd side, pm, 21 (23, 25) sts from Hexagon 9 for 3rd side, pm, 21 (23, 25) sts from Hexagon 2 for 4th side, pm, CO 1 st (selvage st)—86 (94, 102) sts; 21 (23, 25) sts each in 4 sections, 1 selvage st each side. Beg with Row 5 (3, 1), work Hexagon chart back and forth in rows through Row 25—6 sts rem. Remove markers, break yarn, draw tail through all sts, and pull snugly. Weave in ends.

**Hexagon 20 (partial hexagon)**

With dpn and using long-tail method, CO 1 st (selvage st), pm. With RS facing and using main yarn and CO tail alternately, pick up and knit 21 (23, 25) sts from Hexagon 1 for first side, pm, 21 (23, 25) sts from Hexagon 7 for 2nd side, pm, 21 (23, 25) sts from Hexagon 12 for 3rd side, pm, 21 (23, 25) sts from Hexagon 5 for 4th side, pm, CO 1 st (selvage st)—86 (94, 102) sts; 21 (23, 25) sts each in 4 sections, 1 selvage st each side. Complete as for Hexagon 19.

**FINISHING****Cap sleeves**

**Shallower armholes only:** With shorter cir needle and RS facing, beg in “valley” at center of underarm, pick up and knit 21 (23, 25) sts from Hexagon 19, pm, 21 (23, 25) sts from first half of Hexagon 3, pm, 21 (23, 25) sts from 2nd half of Hexagon 3, pm, and 21 (23, 25) sts from Hexagon 19, ending in center of underarm—84 (92, 100) sts. Pm and join in the rnd. Purl 1 rnd. Work short-rows (see Glossary) as foll:

**Short-Rows 1 (RS) and 2 (WS):** Knit to 22 (24, 26) sts before end-of-rnd marker, wrap next st, turn.

**Short-Rows 3–8:** Knit to 3 sts before previous wrapped st, wrap next st, turn.

**Next row:** Knit to beg-of-rnd m in center of underarm. **Next rnd:** Purl 1 rnd on all sts. BO all sts using picot BO (see Stitch Guide). Work 2nd cap sleeve in same manner, beg in center of underarm “valley” and picking up from Hexagons 20 and 6.

**Deeper armholes only:** With shorter cir needle and RS facing, beg in “valley” at center of underarm, pick up and knit 21 (23, 25) sts from Hexagon 9, pm, 21 (23, 25) sts from Hexagon 2, pm, 21 (23, 25) sts from first half of Hexagon 3, pm, 21 (23, 25) sts from 2nd half of Hexagon 3, pm, 21 (23, 25) sts from Hexagon 4,

pm, and 21 (23, 25) sts from Hexagon 10—126 (138, 150) sts. Pm and join in the rnd. Purl 1 rnd. Work short-rows (see Glossary) as foll:

**Short-Rows 1 (RS) and 2 (WS):** Knit to 43 (47, 51) sts before end-of-rnd m, wrap next st, turn.

**Short-Rows 3–8:** Knit to 3 sts before previous wrapped st, wrap next st, turn.

**Next row:** Knit to beg-of-rnd m in center of underarm.

**Next rnd:** Purl 1 rnd on all sts. BO all sts using picot BO (see Stitch Guide). Work 2nd cap sleeve in same manner, beg in center of underarm “valley,” and picking up from Hexagons 12, 5, 6, 1, and 7.

**Neck edging:** With RS facing and shorter cir needle, pick up and knit 21 (23, 25) sts from one side each of Hexagons 1, 2, 3, 4, 5, and 6—126 (138, 150) sts. Purl 1 rnd, knit 1 rnd, purl 1 rnd. BO all







# knitting daily TV

make time for yarn every day

Join Eunny Jang, editor of *Interweave Knits*,  
on the latest season of *Knitting Daily TV*!



Knitting Daily TV  
SERIES 600  
is now airing!

Visit [KnittingDailyTV.com](http://KnittingDailyTV.com) to:

- WATCH streaming videos
- Download FREE patterns
- Download FREE tips and tricks
- Post comments and questions to the *Knitting Daily TV* forums
- Find your local PBS station airing *Knitting Daily TV*
- and MORE!

Purchase *Knitting Daily TV* Series 600, now available on DVD! This **4-DVD set** includes all **13 episodes**

**PLUS 2** never-been-aired in-depth tutorial **BONUS** segments with host Eunny Jang on twisted stitches and the brioche stitch!

Available at your local yarn store or online at [InterweaveStore.com](http://InterweaveStore.com)

Thanks to our knitting daily sponsors:



The BagSmith, Bijous Basin Ranch, Brown Sheep, Conjoined Creations, Eucalan, Prism Arts Inc., Red Heart Yarns, Trendsetter Yarns, Westminster Fibers



sts using picot BO. With tail threaded on a tapestry needle, sew ends of BO rnd tog. Weave in end. **Lower body edging:** With longer cir needle and RS facing, beg in the “valley” where two hexagons meet, pick up and knit 21 (23, 25) sts from each hexagon side all the way around the lower edge—252 (276, 300) sts total. Purl 1 rnd. **Next rnd:** \*K2tog, k18 (20, 22), yo, k1 on one side of “peak,” k1 on other side of “peak,” yo, k18 (20, 22), ssk; rep from \* 5 more times. Purl 1 rnd. BO all sts using picot BO. Weave in ends. Steam-block finished garment on WS.

**Maria Leigh** is a fashion designer and avid knitter. She has relocated from Korea and lives in Ontario, Canada, with her husband and her cat, Tarae (which means yarn ball in Korean). Maria blogs at [www.amigurumikr.com](http://www.amigurumikr.com).

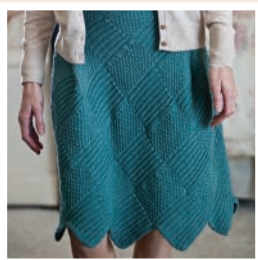

## DIMINISHING GORE SKIRT

Gwen Bortner

**Finished Size** 23 (26, 28½, 31¾, 34½, 37½)" waist circumference, 50¼ (55, 60, 64¾, 69¾, 74½)" hip circumference, and 23½ (25¾, 28, 27, 29, 31)" long. Skirt shown measures 26" at waist.

**Yarn** Green Mountain Spinnery Cotton Comfort (80% wool, 20% organic cotton; 180 yd [165 m]/2 oz): weathered green, 8 (10, 11, 12, 14, 16) skeins.

**Needles** Waistband—size 5 (3.75 mm): 24" circular (cir). Skirt—size 4 (3.5 mm): 36" or longer cir. Adjust needle size if necessary to obtain the correct gauge.

**Notions** Waste yarn; markers (m); 1" wide non-roll elastic about 2" longer than waist measurement; safety pins; sewing needle and thread; tapestry needle.

**Gauge** 25 sts and 34 rows = 4" in St st on larger needle; 29 sts and 40 rows = 4" in woven patt on smaller needle.

### NOTES

- The base number of stitches defines how many stitches are to be picked up for each rectangle. Rectangles increase by two stitches on Tiers 2, 3, and 4. Break yarn after each tier.

### Stitch Guide

**Purl Twist (PT):** P2tog but do not drop sts from left needle, purl first st again and drop both sts from left needle.

**Woven Pattern:** (multiple of 4 sts + 2 [0, 2, 0, 2, 0])

**Row 1:** (RS) K1 (2, 1, 2, 1, 2), \*PT (see Stitch Guide), k2; rep from \* to last 1 (2, 1, 2, 1, 2) st(s) of rectangle, k1 (2, 1, 2, 1, 2).

**Rows 2 and 4:** Purl.

**Row 3:** K1 (2, 1, 2, 1, 2), \*k2, PT; rep from \* to last 1 (2, 1, 2, 1, 2) st(s) of rectangle, k1 (2, 1, 2, 1, 2).

Rep Rows 1–4 for patt.

### Left-Leaning Base Triangle (LBT):

(3-row welt)

**Row 1:** (RS) K1.

**Row 2:** P1.

**Row 3:** K1, ssk.

**Row 4:** Knit sts from previous row.

**Row 5:** Purl 1 more st than previous row.

**Row 6:** Knit sts from previous row.

**Row 7:** Knit sts from previous row, ssk.

**Row 8:** Purl sts from previous row.

**Row 9:** Knit 1 more st than previous row.

**Row 10:** Knit sts from previous row.

**Row 11:** Purl sts from previous row, p2tog.

**Row 12:** Knit sts from previous row.

**Row 13:** Knit 1 more st than previous row.

**Row 14:** Purl sts from previous row.

**Row 15:** Knit sts from previous row, ssk. Rep Rows 4–15 until there are 16 (18, 20, 22, 24, 26) sts on right needle, ending with a RS row.

**Right-Leaning Rectangle (RR):** (woven patt; multiple of 4 sts + 2 [0, 2, 0, 2, 0])

**Set-up row:** (WS) Pick up and purl the base number of sts.

**Row 1:** K1 (2, 1, 2, 1, 2), \*PT, k2; rep from \* to last 1 (2, 1, 2, 1, 2) st(s) of rectangle, k1 (2, 1, 2, 1, 2).

**Rows 2 and 4:** Purl to last st of rectangle, p2tog (1 st from rectangle with 1 st from previous tier to join).

**Row 3:** K1 (2, 1, 2, 1, 2), \*k2, PT; rep from \* to last 1 (2, 1, 2, 1, 2) st(s) of rectangle, k1 (2, 1, 2, 1, 2).

Rep Rows 1–4 until all sts from unit on previous tier have been joined, ending with a WS row.

**Left-Leaning Rectangle (LR):** (3-row welt)

**Set-up row:** (RS) Pick up and knit the base number of sts.

**Row 1:** Purl.

**Rows 2 and 6:** Knit to last st of rectangle, ssk (1 st from rectangle with 1 st from previous tier to join).

**Rows 3 and 5:** Knit.

**Row 4:** Purl to last st of rectangle, ssp (1 st from rectangle with 1 st from previous tier to join).

Rep Rows 1–6 until all sts from unit on previous tier have been joined, ending with a RS row.

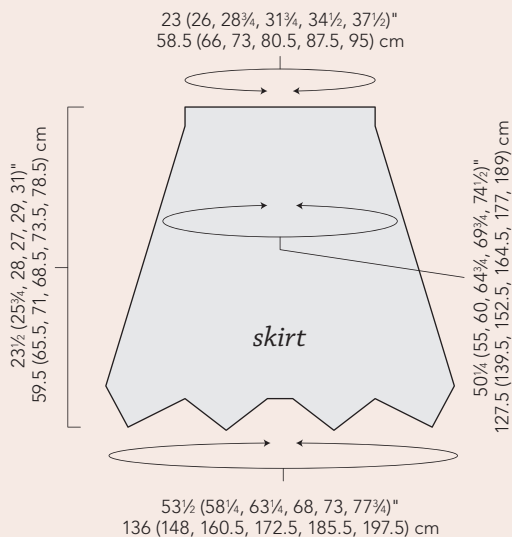



**CASCADE YARNS**  
DISTRIBUTOR OF FINE YARN

# LUNA

100% Peruvian Cotton

63 Colors

Easy Care

Great Texture

Stitch Gauge 4 to the Inch



Download the Susie Bonell  
Pattern free at [cascadeyarns.com](http://cascadeyarns.com)





## SKIRT

**Waistband:** With larger needle, waste yarn, and using the invisible provisional method (see Glossary), CO 144 (162, 180, 198, 216, 234) sts. Working in rows, work 9 rows in St st, beg and ending with a RS row. Knit 1 WS row for turning ridge.

**Next row:** (RS) Knit to end; with RS still facing, place marker (pm) and join in the rnd. Knit 8 rnds. Remove provisional CO and place sts onto smaller needle. Fold work along turning ridge with WS tog and join hem as foll: \*K2tog (1 st from working needle and 1 st from back needle); rep from \* around. **Skirt:**

**Tier 1:** Change to smaller needle. Work 6 LBT (see Stitch Guide)—96 (108, 120, 132, 144, 156) sts.

**Tier 2:** Work 6 RR with 18 (20, 22, 24, 26, 28) sts as the base number—108 (120, 132, 144, 156, 168) sts.

**Tier 3:** Work 6 LR with 20 (22, 24, 26, 28, 30) sts as the base number—120 (132, 144, 156, 168, 180) sts.

### Gore:

**Tier 4:** \*\*Work RR with 22 (24, 26, 28, 30, 32) sts as the base number, \*pick up and purl 22 (24, 26, 28, 30, 32) sts along the selvedge edge of the unit of the previous tier, work woven patt (see Stitch Guide) for 40 (44, 48, 52, 56, 60) rows, work RR with 22 (24, 26, 28, 30, 32) sts as the base number, picking up sts along the edge of the rectangle just created; rep from \* for 2nd gore. Rep from \*\* for 2nd half of skirt—10 units: 6 RR and 4 woven

patt rectangles; 220 (240, 260, 280, 300, 320) sts.

**Tier 5:** Work 10 LR with 22 (24, 26, 28, 30, 32) sts as the base number.

**Tier 6:** Work 10 RR with 22 (24, 26, 28, 30, 32) sts as the base number.

**Tiers 7 and 8:** Rep Tiers 5 and 6.

**Sizes 23 (26, 28¾)" waist only:**

**Tier 9:** Work 10 LR with 22 (24, 26) sts as the base number. With RS facing and larger needle, [pick up and knit 22 (24, 26) sts, k22 (24, 26)] 10 times—440 (480, 520) sts. Purl 4 rnds. BO all sts pwise.

**Sizes 31¼ (34½, 37½)" waist only:**

With RS facing and larger needle, [k28 (30, 32), pick up and knit 28 (30, 32) sts] 10 times—560 (600, 640) sts. Purl 4 rnds. BO all sts pwise.

## FINISHING

Block as necessary. Place safety pin at beg of elastic; measure elastic around waist with a 1" overlap and mark with 2nd safety pin. Use first safety pin to push elastic through waistband casing at split, temporarily securing elastic to skirt with 2nd safety pin when it reaches the slit. Pin ends of elastic tog, making sure it isn't twisted; try skirt on to check and adjust fit. Trim excess elastic and sew ends tog. Sew slit closed. Weave in ends. Block again, if desired.

*Gwen Bortner*, owner of Knitability, dreams in entrelac because she has recently completed her first book, *Entrée to Entrelac*

(XRX Books, 2010), which is focused solely on the technique. Most of the time she is traveling all over the country teaching and sharing her love of knitting with anyone who is interested.

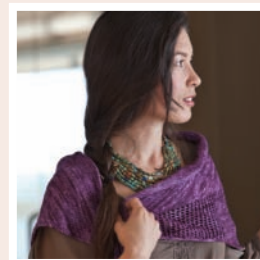

## PINKERTON SHAWL

Susan Dittrich

**Finished Size** 48" wide at top edge and 23" high at point.

**Yarn** Hazel Knits Artisan Sock (90% superwash merino, 10% nylon; 400 yd [366 m]/120 g): violeta, 2 skeins.

**Needles** Shawl body—size 4 (3.5 mm): 40" circular (cir). BO—size 7 (4.5 mm). Adjust needle size if necessary to obtain the correct gauge.

## CUSTOMIZE IT

You could work this shawl in two colors: one for the stockinette triangle and one for the lace triangle. Or you could work each triangle section in stripes to highlight the nontraditional construction.

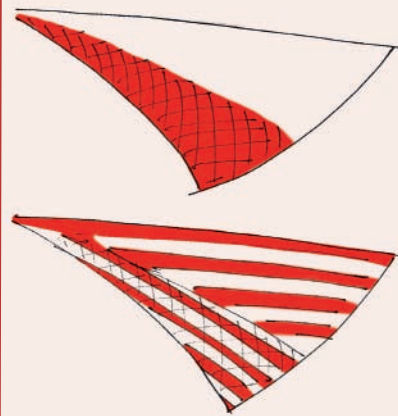

**Notions** Removable marker (m) or safety pin; tapestry needle; blocking pins; lace blocking wires (optional).

**Gauge** 22 sts and 32 rows = 4" in St st on smaller needle.

#### NOTES

- It is helpful to place a safety pin or split-ring marker in the wrapped stitch because the wrapped stitch can sometimes be difficult to see. When making the next wrap, remove the marker from the previous wrap and place it in the new wrapped stitch.

#### SHAWL

With smaller needle, CO 242 sts. Do not join. **St st triangle:** Shape triangle using short-rows (see Glossary) as foll:

**Row 1:** (WS) Purl to last 3 sts, wrap next st, turn; place marker (pm) in wrapped st (see Notes).

**Row 2:** (RS) Knit to last 2 sts, k2tog—1 st dec'd.

**Row 3:** Purl to 3 sts before previously wrapped st, wrap next st, turn; remove m from previously wrapped st and pm in new wrapped st.

Rep Rows 2 and 3 fifty-eight more times, then work Row 2 once more—182 sts rem.

**Next row:** (WS) Purl to end of row, working wraps tog with wrapped sts as you come to them. **Mesh lace triangle:**

**Row 1:** (RS) \*K2tog, yo; rep from \* to last 2 sts, k2tog—181 sts rem.

**Row 2:** (WS) Purl to last 3 sts, wrap next st, turn.

**Row 3:** \*K2tog, yo; rep from \* to last 2 sts, k2tog—1 st dec'd.

**Row 4:** Purl to 3 sts before previously wrapped st, wrap next st, turn.

Rep Rows 3 and 4 forty-three more times—137 sts rem. Work Row 3 once more—136 sts rem. With larger needle and WS facing, very loosely BO all sts pwse, working wraps tog with wrapped sts as you BO.

#### FINISHING

Weave in ends. Block to measurements.

*Susan Dittrich* lives in Pittsburgh, Pennsylvania, and can be found knitting in coffee shops. She blogs now and then at [www.handknitsbysusan.wordpress.com](http://www.handknitsbysusan.wordpress.com).

• • • • •

We carry everything  
from tempting,

hand-painted

*luxury* yarns to  
reliable favorites.

# Westport Yarns

*A gathering place for everyone from the curious beginner to the completely obsessed.*

[www.westportyarns.com](http://www.westportyarns.com) • 582 Post Rd. E. • Westport, CT • 203-454-4300



Pattern 20108 in Balance

o-wool™  
organic  
it just feels right

<http://www.o-wool.com> - 888.673.0260  
[info@funneywoolcompany.com](mailto:info@funneywoolcompany.com)

## the mannings Handweaving School & Supply Center



1132 Green Ridge Road  
PO Box 687  
East Berlin, PA 17316  
717-624-2223  
orders - 1-800-233-7166

We stock what every knitter needs: Knitting Books (over 400 titles), patterns from Fiber Trends, Sarah James, Lucy Neatby, etc., yarns from Brown Sheep, Koigu, Skacel, Plymouth, Noro, Opal, etc., knitting needles, tons of knitting gadgets and a large selection of the popular sock and scarf yarns. [www.the-mannings.com](http://www.the-mannings.com)

## Protect and Organize Your Back Issues

Keep this valuable source of information fresh and available for reference. Slipcases are library quality. Constructed with heavy bookbinder's board and covered in a rich maroon leather grained material. A gold label with the *Knits* logo is included.

**One - \$18 Three - \$45 Six - \$84**

*Add \$3.50 per slipcase for P&H - USA orders only*

Send to: **TNC Enterprises Dept. IWK**  
P.O. Box 2475  
Warminster, PA 18974

Enclose name, address (*No P.O. boxes please*) and payment with your order.

PA residents add 6% sales tax. You can even call **215-674-8476** to order by phone.

**Credit Card Orders:** Visa, MC, AmEx accepted. Send name, number, exp. date and signature.

To Order Online: [www.tncenterprises.net/iwk](http://www.tncenterprises.net/iwk)



**LARA BUBBLE TOP**  
by **FAINA GOBERSTEIN. PAGE 96.**  
YARN Schulana Merino Cotton 135,  
distributed by Skacel



— steady decreases  
along a center  
line create an  
A-line shape

— smooth cotton  
creates drape

/ dramatic increases  
after a cabled band  
create ruffles

# Circumnavigated

Carefully planned knitting geometry  
yields smooth curves and  
more-than-circular fabrics.



knitting begins at the  
back of the neck

vest fronts curve with  
short-rows around the front

fronts grow into sideways-  
knitted back pieces

**DRAPED VEST**  
by **CAROL FELLER. PAGE 98.**  
YARN Mango Moon Dharma



**RUCHED YOKE TEE**  
 by ANNELENA MATTISON. PAGE 100.  
 YARN Blue Sky Alpacas Skinny Cotton

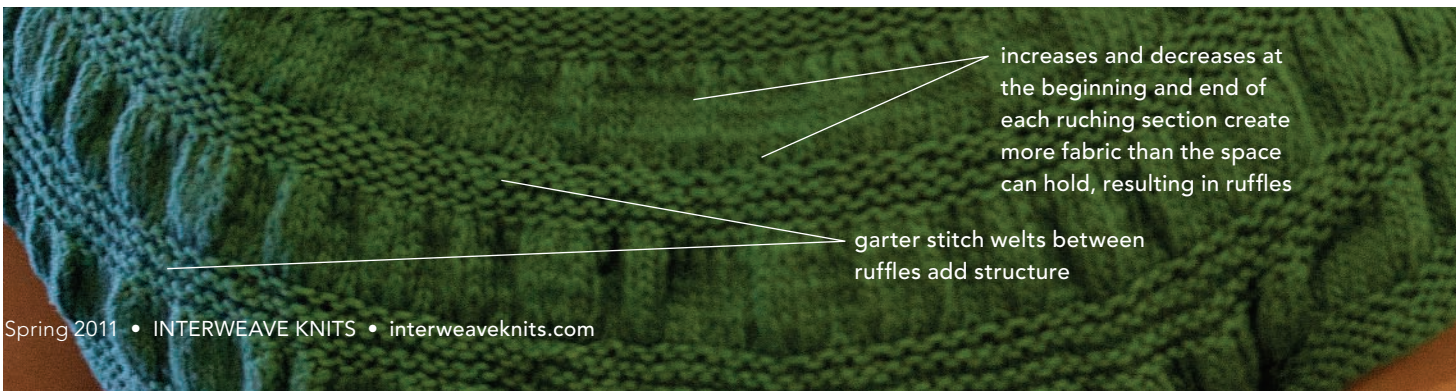

increases and decreases at the beginning and end of each ruching section create more fabric than the space can hold, resulting in ruffles

garter stitch welts between ruffles add structure



**GOSSAMER SMOCKED TUNIC**  
by **SHELLEY GERBER. PAGE 102.**  
YARN Shibui Knits Silk Cloud

wrapping yarns around groups of stitches smocks plain fabric and creates a nipped waist

sheer mohair stockinette gathers under the smocking



## LARA BUBBLE TOP

Faina Goberstein

**Finished Size** 31½ (34¾, 38%, 42¾, 48¾, 53¾)" bust circumference. Top shown measures 34¾", modeled with about 2" of ease.

**Yarn** Schulana Merino Cotton 135 (53% merino, 47% cotton; 148 yd [135 m]/50 g): #61 flax, 7 (8, 9, 10, 12, 13) balls. Yarn distributed by Skacel.

**Needles** Body—size 6 (4 mm): 16" and 32" circulars (cir). Cable border—size 4 (3.5 mm): 16" and 24" cir. Adjust needle size if necessary to obtain the correct gauge.

**Notions** Stitch holders; markers (m); cable needle (cn); tapestry needle.

**Gauge** 24 sts and 33 rnds = 4" in St st on larger needle; 26 sts and 45 rnds = 4" in cable patt on smaller needle.

### NOTES

- The body is worked in the round to the armhole. Back and front are worked separately to the beginning of the yoke. At this point, all existing stitches and newly cast-on stitches for sleeve caps are joined for the yoke.
- For sizes 38¾ (42¾, 48¾, 53¾)" only, decreases above the armhole will be worked on wrong-side rows as well as right-side rows. Work a wrong-side decrease row as follows: Purl to 3 sts before m, p2tog, p1, sl m, ssp, purl to end—2 sts dec'd.

### BODY

**Cable border:** With smaller needle, CO 216 (234, 270, 297, 324, 351) sts. Place marker (pm) and join in the rnd. Rnd beg at left side "seam." [Purl 1 rnd, knit 1 rnd] 2 times. Work Rnds 1–10 of Cable chart 2 times. Purl 1 rnd. **Next rnd:** Knit and inc 0 (inc 2, inc 2, dec 1, dec 0, dec 3) st(s) evenly spaced—216 (236, 272, 296, 324, 348) sts. Purl 1 rnd. **Lower body:** Change to larger needle and St st. **Inc rnd:** \*K1, [k1f&b, k1] 26 (29, 33, 36, 40, 43) times, [k1f&b] 1 (0, 0, 0, 0) time, k0

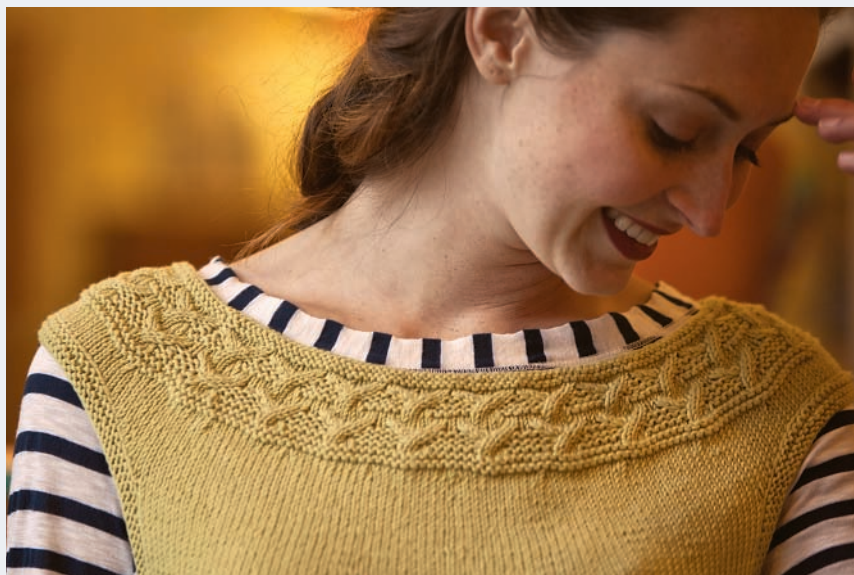
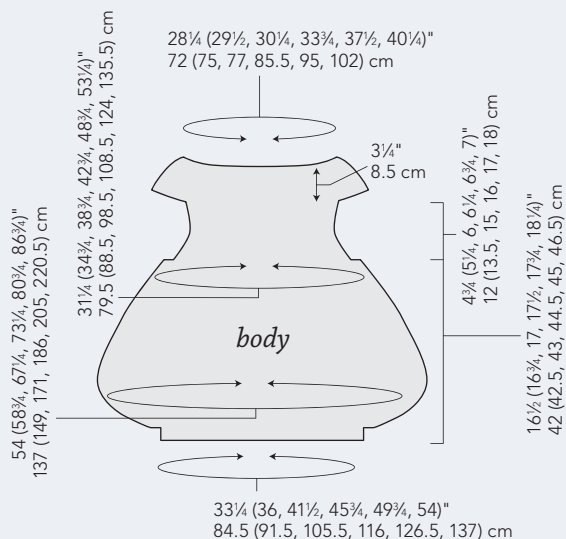



## Invite topnotch knitwear designers into your fiber studio for one-on-one knitting lessons!

### NEW! *Knitting from the Top Down with Wendy Bernard*

In this workshop video, knitter extraordinaire Wendy Bernard shares her expertise for knitting top-down sweaters and demonstrates a top-down raglan pullover and a set-in sleeve cardigan pattern. With the tips and techniques you'll learn from this step-by-step approach, you'll become an expert on knitting from the top down, and you can practice your skills with two free patterns available with purchase of this workshop.

### NEW! *Knitting Creative Details: Designing Original Knitwear with Vicki Square*

In this workshop video, best-selling author Vicki Square shares her expertise designing one-of-a-kind knitwear, with special attention to the details. You'll learn to envision your designs, use schematics properly, embroidery techniques, and more. Plus, you'll have access to three free patterns shown on this video.



Shop Knitting Daily Workshop DVDs at your local yarn shops and online at [InterweaveStore.com](http://InterweaveStore.com)

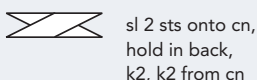
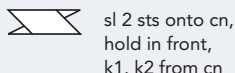
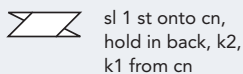

## Cable

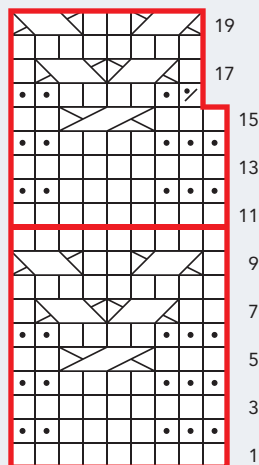

(0, 1, 1, 0, 0), pm; rep from \* to end—324 (352, 404, 440, 484, 520) sts. Work 5 (5, 4, 4, 4, 4) rnds even. **Dec rnd:** \*K1, k2tog, knit to 2 sts before m, ssk, sl m; rep from \* to end—8 sts dec'd. Rep Dec rnd every 6 (6, 5, 5, 5, 5) rnds 14 (16, 19, 21, 22, 24) more times—204 (216, 244, 264, 300, 320) sts rem. Work 5 (5, 4, 4, 4, 4) rnds even. **Dec rnd:** (Center front and back only) \*Knit to 2 sts before m, ssk, sl m, k1, k2tog, knit to m, sl m; rep from \* once more, knit to end—4 sts dec'd. Rep Dec rnd every 6 (6, 5, 5, 5, 5) rnds 3 more times and **at the same time** when piece measures 16½ (16¾, 17, 17½, 17¾, 18¼)" from CO, end 4 (5, 6, 6, 7, 7) sts before end of rnd on last rnd, then divide for front and back as foll: BO 8 (10, 12, 12, 14, 14) sts, work to 4 (5, 6, 6, 7, 7) sts before side m, BO 8 (10, 12, 12, 14, 14) sts, work to end of rnd. Place front sts on holder.

## BACK

Working back and forth in rows, cont with center-back shaping (see Notes) and **at the same time** shape armholes as foll: Purl 1 WS row. BO 3 sts at beg of next 0 (0, 0, 4, 4, 4) rows, then 2 sts at beg of foll 4 (4, 6, 6, 8, 8) rows. Dec 1 st each edge every RS row 2 (2, 4, 2, 5, 7) times—74 (78, 82, 84, 90, 96) sts rem when all armhole and center-back shaping is completed. Work even in St st until armholes measure 4 (4½, 5, 5½, 5¾, 5¾)" ending with a WS row. Inc 1 st each edge every RS row 3 (3, 4, 4, 5, 5) times—80 (84, 90, 92, 100, 106) sts. Work 1 WS row—armholes measure about 4¾ (5¼, 6, 6¼, 6¾, 7)". Place sts on holder.

## FRONT

With WS facing, join yarn at armhole edge. Work as for back but do not place sts on holder.

## YOKE

**Next row:** (RS) K80 (84, 90, 92, 100, 106) front sts, CO 26 (29, 39, 48, 61, 66) sts for right sleeve cap using the backward-loop method; k80 (84, 90, 92, 100, 106) back sts, CO 26 (29, 39, 48, 61, 66) sts for left sleeve cap—212 (226, 258, 280, 322, 344) sts. Pm and join in the rnd. Knit 5 rnds. **Next rnd:** Knit, dec 5 (10, 15, 10, 16, 20) sts evenly spaced—207 (216, 243, 270, 306, 324) sts rem. **Top border:** Change to smaller needle. Purl 1 rnd. Knit 1 rnd. Purl 1 rnd. Work Rnds 1–19 of Cable chart once—184 (192, 216, 240, 272, 288) sts rem. **Next rnd:** Knit, dec 0 (0, 20, 21, 29, 27) sts evenly spaced—184 (192, 196, 219, 243, 261) sts rem. Purl 1 rnd. Knit 1 rnd. Purl 1 rnd. BO all sts.

## FINISHING

**Armhole trim:** With larger needle, pick up and knit 82 (94, 114, 126, 146, 154) sts evenly around armhole opening. Pm and join in the rnd. Purl 1 rnd. Knit 1 rnd. Change to smaller needle. Purl 1 rnd. Knit 1 rnd. Purl 1 rnd. BO all sts. Weave in ends. Block piece to measurements.

*Faina Goberstein* is fascinated by the endless possibilities of various knitting techniques and stitch patterns; she blogs at [www.fainasknittingmode.blogspot.com](http://www.fainasknittingmode.blogspot.com). When she is not designing, she enjoys teaching mathematics, traveling, and fine arts.

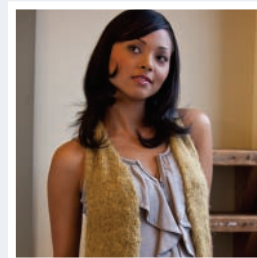

## DRAPED VEST

Carol Feller

**Finished Size** 35 (39, 43, 47, 51, 55)" bust circumference. Vest shown measures 39", modeled with 6" of ease.

**Yarn** Mango Moon Dharma (100% recycled silk; 150 yd [137 m]): #9415 wheat, 3 (3, 4, 4, 5, 6) skeins.

**Needles** Size 9 (5.5 mm): straight and set of double-pointed (dpn). Adjust needle size if necessary to obtain the correct gauge.

**Notions** Markers (m); waste yarn; tapestry needle; size 7 (4.5 mm) crochet hook.

**Gauge** 16 sts and 22 rows = 4" in St st; 14 sts and 24 rows = 4" in St st, measured with the fabric held sideways.

## NOTES

- The vest is worked in two mirror-image halves, each starting at the back neck and worked down the front, then curved around the side of the lower body using short-rows, and ending at center back.
- The back portion of the vest is worked from side to side. The weight of the silk will cause the fabric to stretch slightly, making the stitch gauge larger than when the fabric is hanging from the needles during knitting. If you substitute a different yarn, check to be sure that it behaves similarly.
- The yarn used in this vest is recycled silk with distinctive characteristics and significant variations in yarn thickness, so it is advisable to wind and check all the skeins before beginning.
- To choose a size, allow for 3" of ease at the bustline so the back can drape softly from where it is gathered at the neckline. For example, if you have a 36" bust, choose the 39" size for a vest that will meet in the front and have 3" positive ease to accommodate the back drape.
- Slip the first stitch of right-side rows knitwise and slip the first stitch of wrong-side rows purlwise.

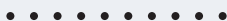

**RIGHT HALF**

**Neckband:** With dpn and using the invisible provisional method (see Glossary), CO 14 (16, 16, 18, 18, 20) sts. Place marker (pm) and join in the rnd. Work in St st (knit every rnd) until piece measures 2 (2½, 2¾, 3, 3, 3)" from CO. Remove m.

**Shape front neck:** Beg working in rows, changing to straight needles as soon as possible.

**Row 1:** (RS) Sl 1 (see Notes), knit to end.

**Row 2:** (WS) Sl 1, purl to end.

**Row 3:** Sl 1, knit to last st, M1L, k1—1 st inc'd at front edge.

**Row 4:** Rep Row 2.

Rep last 4 rows 11 (11, 10, 11, 8, 10) more times—26 (28, 27, 30, 27, 31) sts. Rep Rows 3 and 4 only 2 (2, 5, 4, 9, 6) times—28 (30, 32, 34, 36, 37) sts; piece measures about 9¾ (9¾, 10¼, 10½, 10¼, 10½)" from end of neckband worked in the rnd (front neck depth). Work 6 (2, 4, 2, 0, 0) rows even in St st. **Shape front armhole:**

(RS) Sl 1, M1R, knit to end—1 st inc'd at armhole edge. **Next row:** (WS) Sl 1, purl to end. Rep last 2 rows 1 (3, 3, 1, 3, 2) more time(s)—30 (34, 36, 36, 40, 40) sts. **Next row:** (RS) Sl 1, M1R, knit to end—1 st inc'd at armhole edge. **Next row:** (WS) Sl 1, purl to last st, M1P, p1—1 st inc'd at armhole edge. Rep last 2 rows 0 (0, 1, 3, 3, 5) more time(s)—32 (36, 40, 44, 48, 52) sts. Shape lower body curve with short-rows (see Glossary) as foll: **First set of short-rows:**

**Row 1:** (RS) Sl 1, knit to end.

**Row 2:** (WS) Sl 1, p1, wrap next st, turn.

**Row 3:** Knit to end.

**Row 4:** Sl 1, purl to wrapped st, purl wrap tog with wrapped st, p1, wrap next st, turn. Rep last 2 rows 13 (15, 17, 19, 21, 23)

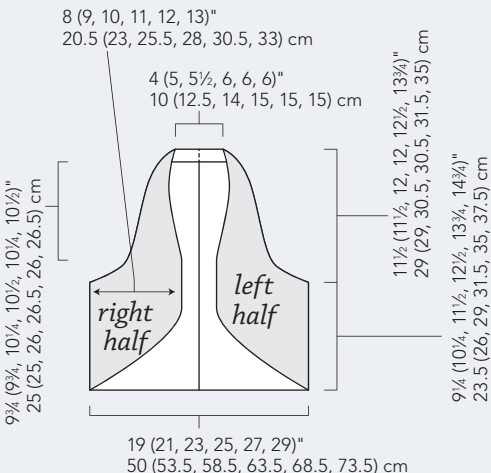
**Tech Tip**

"I am fascinated by short-rows and seamless construction. This vest grew organically from the idea of working a vest that fit well but was effectively just one continuous strip of knitting joined only at the back of the neck. The gentle front curves are formed entirely with short-rows to move from knitting vertically to horizontally."

—Carol Feller

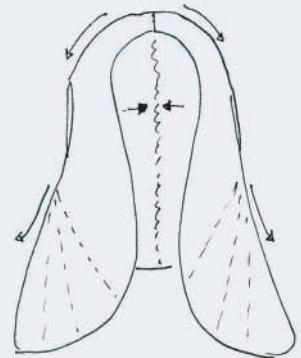

more times, ending with a WS row; last wrapped st is 2nd st from end of WS row.

**Next row:** (RS) Knit to end. **Next row:** (WS) Sl 1, purl to end, working wrap tog with wrapped st. **Second set of short-rows:**

**Row 1:** (RS) Sl 1, knit to end.

**Row 2:** (WS) Purl to last 2 sts, wrap next st, turn.

**Row 3:** Knit to end.

**Row 4:** Work to 2 sts before previous wrapped st, wrap next st, turn.

Rep last 2 rows 13 (15, 17, 19, 21, 23) more times, ending with a WS row; last wrapped st is 3rd st of WS row. **Next**

**row:** (RS) Knit to end. **Next row:** (WS) Sl 1, purl to end, working wraps tog with wrapped sts. **Shape back armhole:**

Mark each end of last row completed to indicate beg of back. **Next row:** (RS) Sl 1,

M1R, knit to end—1 st inc'd at armhole edge. **Next row:** (WS) Sl 1, purl to last

st, M1P, p1—1 st inc'd at armhole edge. Rep last 2 rows 1 (2, 2, 1, 2, 2) more

time(s)—36 (42, 46, 48, 54, 58) sts. Cont in patt, inc 1 st at armhole edge every

RS row 3 (5, 5, 8, 10, 12) times—39 (47, 51, 56, 64, 70) sts. Cont in patt, inc 1 st

at armhole edge every 4th row 6 (5, 6, 6, 6, 6) times—45 (52, 57, 62, 70, 76) sts. Work 1 WS row even. **Back:** Measure all

back lengths after allowing back to hang

(as it will when worn) until it matches the sideways gauge. **Next row:** (RS)

Using cable method (see Glossary), CO 27 (24, 25, 24, 22, 24) sts, knit to end—72

(76, 82, 86, 92, 100) sts; piece measures about 5¼ (6¼, 6¾, 7½, 8½, 9¼)" from marked row. Work even in patt until piece

measures 9½ (10½, 11½, 12½, 13½, 14½)" from marked row, ending with a WS row. Cut yarn, leaving long tail for grafting.

Place sts on waste yarn.

#### LEFT HALF

**Neckband:** Carefully remove provisional CO from right half neckband and place 14 (16, 16, 18, 18, 20) sts on dpn. Pm and join in the rnd. Mark the provisional CO row. Work in St st until piece measures 2 (2½, 2¾, 3, 3, 3)" from CO marker. Remove end-of-rnd m. **Shape front neck:** Beg working in rows, changing to straight needles as soon as possible.

**Row 1:** (RS) Sl 1, knit to end.

**Row 2:** (WS) Sl 1, purl to end.

**Row 3:** Sl 1, M1R, knit to end—1 st inc'd at front edge.

**Row 4:** Rep Row 2.

Rep last 4 rows 11 (11, 10, 11, 8, 10)

more times—26 (28, 27, 30, 27, 31) sts.

Rep Rows 3 and 4 only 2 (2, 5, 4, 9, 6) times—28 (30, 32, 34, 36, 37) sts; piece

measures about 9¼ (9¾, 10¼, 10½, 10¾, 10½)" from end of neckband worked in the rnd (front neck depth). Work 6 (2, 4,

2, 0, 0) rows even in St st. **Shape front armhole:** (RS) Sl 1, knit to last st, M1L,

k1—1 st inc'd at armhole edge. **Next row:** (WS) Sl 1, purl to end. Rep last 2 rows 1

(3, 3, 1, 3, 2) more time(s)—30 (34, 36, 36, 40, 40) sts. **Next row:** (RS) Sl 1, knit

to last st, M1L, k1—1 st inc'd at armhole edge. **Next row:** (WS) Sl 1, M1P, purl to

end—1 st inc'd at armhole edge. Rep last 2 rows 0 (0, 1, 3, 3, 5) time(s)—32 (36,

40, 44, 48, 52) sts. Shape lower body curve with short-rows as foll: **First set of short-rows:**

**Row 1:** (RS) Sl 1, k1, wrap next st, turn.

**Row 2:** (WS) Purl to end.

**Row 3:** Sl 1, knit to wrapped st, knit wrap tog with wrapped st, k1, wrap next st, turn.

**Row 4:** Purl to end.

Rep last 2 rows 13 (15, 17, 19, 21, 23) more times, ending with a WS row; last

wrapped st is 2nd st from end of RS row. **Next row:** (RS) Sl 1, knit to end, working

wrap tog with wrapped st. **Next row:**

(WS) Sl 1, purl to end. **Second set of short-rows:**

**Row 1:** (RS) Sl 1, knit to last 2 sts, wrap next st, turn.

**Row 2:** (WS) Purl to end.

**Row 3:** Sl 1, knit to 2 sts before previous wrapped st, wrap next st, turn.

**Row 4:** Purl to end.

Rep last 2 rows 13 (15, 17, 19, 21, 23) more times, ending with a WS row; last wrapped st is 3rd st of RS row. **Next row:**

(RS) Sl 1, knit to end, working wraps tog with wrapped sts. **Next row:** (WS) Sl 1,

purl to end. **Shape back armhole:** Mark each end of last row completed to indicate

beg of back. **Next row:** (RS) Sl 1, knit to last st, M1L, k1—1 st inc'd at armhole

edge. **Next row:** (WS) Sl 1, M1P, purl to end—1 st inc'd at armhole edge. Rep last

2 rows 1 (2, 2, 1, 2, 2) more time(s)—36 (42, 46, 48, 54, 58) sts. Cont in patt, inc 1

st at armhole edge every RS row 3 (5, 5, 8, 10, 12) times—39 (47, 51, 56, 64, 70) sts.

Cont in patt, inc 1 st at armhole edge every 4th row 6 (5, 6, 6, 6, 6) times—45

(52, 57, 62, 70, 76) sts. **Back:** Measure all back lengths after allowing back to hang.

**Next row:** (WS) Using the cable method, CO 27 (24, 25, 24, 22, 24) sts, purl to

end—72 (76, 82, 86, 92, 100) sts; piece

measures about 5¼ (6¼, 6¾, 7½, 8½, 9¼)" from marked row. Work even in patt until piece measures 9½ (10½, 11½, 12½, 13½, 14½)" from marked row, ending with a WS row. Cut yarn, leave sts on needle.

#### FINISHING

Taking care not to twist body of vest, graft live sts of right and left halves tog at center back using Kitchener stitch (see Glossary) and tail attached to right half. With yarn threaded on a tapestry needle, sew neck edge of back to neckband tube, easing to fit. With crochet hook, work 1 row of single crochet (sc; see Glossary) around armhole openings. Block pieces to measurements. Weave in ends.

*Carol Feller* is a widely published knitwear designer based in Cork, Ireland. Her self-published work can be found at [www.stolenstitches.com](http://www.stolenstitches.com). Watch for her upcoming book with Wiley due for release in Fall 2011.



## RUCHED YOKE TEE

AnneLena Mattison

**Finished Size** Child's: 21½ (23½, 26, 28, 30, 32½)" chest circumference, to fit ages 2 (4, 6, 8, 10, 12). Tee shown measures 21½". Adult's: 34½ (38½, 42½, 46¾, 51¼, 55¼)" bust circumference. Tee shown measures 34½", modeled with about 1½" of ease.

**Yarn** Blue Sky Alpaca Skinny Cotton (100% organically grown cotton; 150 yd [137 m]/65 g): Child's: #312 pear (pale green), 3 (3, 3, 4, 4, 5) skeins. Adult's: #313 basil (green), 6 (7, 7, 8, 9, 10) skeins.

**Needles** Size 6 (4 mm): 24" circular (cir) and 2 double-pointed (dpn). Adjust needle size if necessary to obtain the correct gauge.

**Notions** Markers (m); waste yarn (adult sizes only); tapestry needle.

**Gauge** 20 sts and 34 rnds = 4" in St st.

**NOTES**

- Tee is worked from the top down.

**CHILD'S TEE**

**Yoke:** With cir needle, CO 89 (93, 100, 106, 111, 121) sts. Do not join. Knit 6 rows.

**Row 7:** (RS) K1, \*k1f&b; rep from \* to last st, k1—176 (184, 198, 210, 220, 240) sts.

**Rows 8–12:** Work in St st.

**Row 13:** (RS) K1, \*k2tog; rep from \* to last st, k1—89 (93, 100, 106, 111, 121) sts rem.

**Rows 14–16:** Knit.

**Row 17:** (RS) Knit, inc 23 (27, 30, 34, 35, 37) sts evenly spaced—112 (120, 130, 140, 146, 158) sts.

**Row 18:** Knit.

**Row 19:** K1, \*k1f&b; rep from \* to last st, k1—222 (238, 258, 278, 290, 314) sts.

**Rows 20–24:** Work in St st.

**Row 25:** (RS) K1, \*k2tog; rep from \* to last st, k1; do not turn work; using the backward-loop method, CO 4 sts at end of row—116 (124, 134, 144, 150, 162) sts. Break yarn. With RS still facing, join work in the rnd as foll: sl first 56 (60, 65, 70, 73, 79) sts from left needle to right needle, place marker (pm) for beg of rnd, join yarn.

**Rnds 1 and 3:** Purl.

**Rnd 2:** Knit.

**Rnd 4:** Knit, inc 23 (27, 30, 34, 35, 37) sts evenly spaced—139 (151, 164, 178, 185, 199) sts.

**Rnd 5:** Purl.

**Rnd 6:** \*K1f&b; rep from \* to end—278 (302, 328, 356, 370, 398) sts.

**Rnds 7–11:** Knit.

**Rnd 12:** \*K2tog; rep from \* to end—139

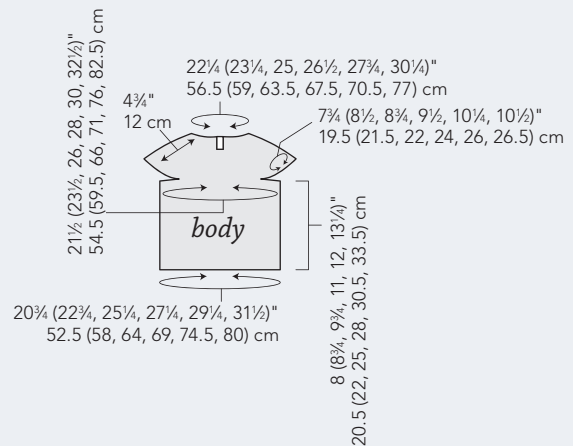
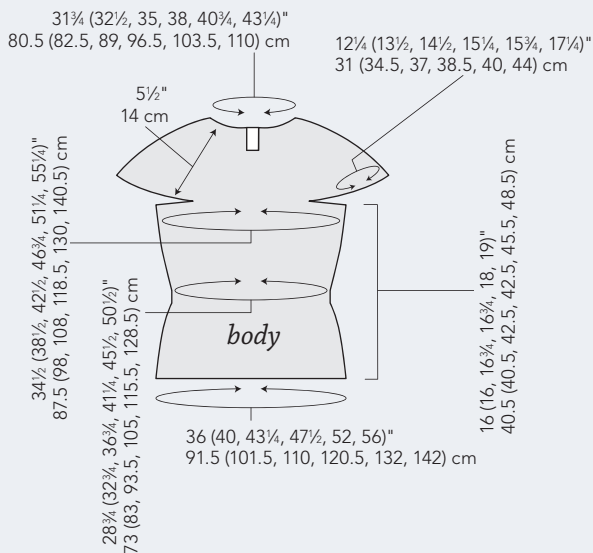

(151, 164, 178, 185, 199) sts rem.

**Rnds 13 and 15:** Purl.

**Rnd 14:** Knit.

**Rnd 16:** Knit, inc 23 (27, 30, 34, 35, 37) sts evenly spaced—162 (178, 194, 212, 220, 236) sts.

**Rnd 17:** Purl.

**Divide for armholes:**

**Rnd 18:** K24 (26, 29, 32, 33, 36) for back, BO 33 (36, 38, 42, 43, 45) sts for right armhole, k48 (53, 59, 64, 67, 73) for front, BO 33 (36, 38, 42, 43, 45) sts for left armhole, k24 (27, 30, 32, 34, 37) for back—96 (106, 118, 128, 134, 146) sts rem for body.

**Rnd 19:** K24 (26, 29, 32, 33, 36) back sts, CO 3 (3, 3, 3, 4, 4) sts for underarm, pm for side, CO 3 (3, 3, 3, 4, 4) sts for underarm, k48 (53, 59, 64, 67, 73) front sts, CO 3 (3, 3, 3, 4, 4) sts for underarm, pm for side, CO 3 (3, 3, 3, 4, 4) sts for underarm, k24 (27, 30, 32, 34, 37) back sts—108 (118, 130, 140, 150, 162) sts.

Knit 6 rnds. **Dec rnd:** \*Knit to 3 sts before side m, k2tog, k1, sl m, k1, ssk; rep from \* once more, knit to end of rnd—104 (114, 126, 136, 146, 158) sts rem.

Work even in St st until piece measures 7½ (8¼, 9¼, 10½, 11½, 12¾)" from underarm. [Purl 1 rnd, knit 1 rnd] 2 times, purl 1 rnd. BO all sts kwise.

## FINISHING

**Front ties:** With dpn, CO 4 sts. Work in I-cord (see Glossary) for 7". **Attach cord:** With RS facing and beg at top of front slit, work attached I-cord as foll: \*Knit 3 I-cord sts, sl last st kwise, pick up and knit 1 st along edge of slit, psso (slipped st over picked-up st), slide sts to other end of needle; rep from \* to bottom of slit. Work 2 rows of attached I-cord across bottom of slit. Work attached I-cord up to top of slit. Work regular (unattached) I-cord for 7". Break yarn, leaving a 6" tail. With tail threaded on a tapestry needle, pull tail through rem sts and pull tight to close. Weave in ends. Block to measurements.

## ADULT'S TEE

**Yoke:** With cir needle, CO 127 (130, 140, 152, 163, 173) sts. Do not join. Knit 8 rows.

**Row 9:** (RS) K1, \*k1f&b; rep from \* to last st, k1—252 (258, 278, 302, 324, 344) sts.

**Rows 10–16:** Work in St st.

**Row 17:** (RS) K1, \*k2tog; rep from \* to last st, k1—127 (130, 140, 152, 163, 173) sts rem.

**Rows 18–20:** Knit.

**Row 21:** (RS) Knit, inc 43 (50, 54, 60,

63, 71) sts evenly spaced—170 (180, 194, 212, 226, 244) sts.

**Rows 22–24:** Knit.

**Row 25:** (RS) K1, \*k1f&b; rep from \* to last st, k1—338 (358, 386, 422, 450, 486) sts.

**Rows 26–32:** Work in St st.

**Row 33:** (RS) K1, \*k2tog; rep from \* to last st, k1; do not turn work; using the backward-loop method, CO 6 sts at end of row—176 (186, 200, 218, 232, 250) sts. Break yarn. With RS still facing, join work in the rnd as foll: sl first 85 (90, 97, 106, 113, 122) sts from left needle to right needle, place marker (pm) for beg of rnd, join yarn.

**Rnds 1 and 3:** Purl.

**Rnd 2:** Knit.

**Rnd 4:** Knit, inc 43 (50, 54, 60, 63, 71) sts evenly spaced—219 (236, 254, 278, 295, 321) sts.

**Rnds 5 and 7:** Purl.

**Rnd 6:** Knit.

**Rnd 8:** \*K1f&b; rep from \* to end—438 (472, 508, 556, 590, 642) sts.

**Rnds 9–15:** Knit.

**Rnd 16:** \*K2tog; rep from \* to end—219 (236, 254, 278, 295, 321) sts rem.

**Rnds 17 and 19:** Purl.

**Rnd 18:** Knit.

**Rnd 20:** Knit, inc 43 (50, 54, 60, 63, 71) sts evenly spaced—262 (286, 308, 338, 358, 392) sts.

**Rnds 21 and 23:** Purl.

**Rnd 22:** Knit.

**Divide for armholes:**

**Rnd 24:** K39 (43, 47, 52, 57, 62) for back, BO 53 (57, 60, 64, 65, 72) sts for right armhole, k78 (86, 94, 105, 114, 124) for front, BO 53 (57, 60, 64, 65, 72) sts for left armhole, k39 (43, 47, 53, 57, 62) for back—156 (172, 188, 210, 228, 248) sts rem for body.

**Rnd 25:** K39 (43, 47, 52, 57, 62) back sts, CO 4 (5, 6, 6, 7, 7) sts for underarm, pm for side, CO 4 (5, 6, 6, 7, 7) sts for underarm, k78 (86, 94, 105, 114, 124) front sts, CO 4 (5, 6, 6, 7, 7) sts for underarm, pm for side, CO 4 (5, 6, 6, 7, 7) sts for underarm, k39 (43, 47, 53, 57, 62) back sts—172 (192, 212, 234, 256, 276) sts.

Knit 11 (11, 12, 12, 12, 12) rnds. **Shape**

**waist:** **Dec rnd:** \*Knit to 3 sts before side m, k2tog, k1, sl m, k1, ssk; rep from \* once more, knit to end of rnd—4 sts dec'd. Rep Dec rnd every 8 (9, 9, 9, 9, 10) rnds 6 (6, 6, 6, 6, 5) more times—144 (164, 184, 206, 228, 252) sts rem. Knit 6 rnds. **Inc rnd:** \*Knit to 1 st before side m, M1L, k1, sl m, k1, M1R; rep from \* once more, knit to end of rnd—4 sts

inc'd. Rep Inc rnd every 5 (7, 7, 8, 8, 8) rnds 8 (8, 7, 7, 7, 6) more times—180 (200, 216, 238, 260, 280) sts. Work in St st until piece measures 15¼ (15¼, 16, 16, 17¼, 18¾)" from underarm. [Purl 1 rnd, knit 1 rnd] 3 times. BO all sts pwise.

## FINISHING

**Front keyhole edging:** With dpn and using the invisible provisional method (see Glossary), CO 4 sts. Work 3 rows of I-cord (see Glossary). **Attach cord:** With RS facing and beg at top of front slit, work attached I-cord as foll: \*K3 I-cord sts, sl last st kwise, pick up and knit 1 st along edge of slit, psso (slipped st over picked-up st), slide sts to other end of needle; rep from \* to bottom of slit. Work 4 rows of attached I-cord across bottom of slit. Work attached I-cord up to top of slit, then work 3 rows of regular (unattached) I-cord. Break yarn, leaving a 6" tail. Remove provisional CO and place sts onto dpn. With tail threaded on a tapestry needle, use Kitchener st (see Glossary) to graft beg and end of I-cord tog. Weave in ends. Block to measurements.

*AnneLena Mattison* began designing and knitting doll clothes at the tender age of five. She lives in Northern California with her husband and six kids (including seven-year-old triplets).

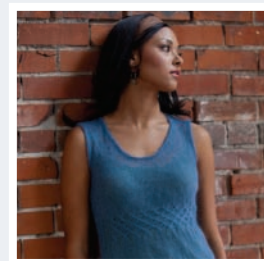

## GOSSAMER SMOCKED TUNIC

Shelley Gerber

**Finished Size** 31¼ (34¾, 38½, 41¼, 48¾)" bust circumference (see Notes for selecting size). Tunic shown measures 34¾", modeled with about 1" of ease.

**Yarn** Shibui Knits Silk Cloud (60% kid mohair, 40% silk; 330 yd [302 m]/25 g): #SC350 storm, 2 (3, 3, 3, 4) skeins.

**Needles** Body—sizes 5 (3.75 mm) and 6 (4 mm): 16" or 24" circulars (cir; choose



length to accommodate finished size). Neck edging—size 4 (3.5mm): 16" cir. Adjust needle size if necessary to obtain the correct gauge.

**Notions** Markers (m); stitch holders or waste yarn; tapestry needle.

**Gauge** 22 sts and 28 rnds = 4" in St st on size 6 needle; 22½ sts and 30 rnds = 4" in St st, 29½ sts and 30 rnds = 4" in smocking patt, and 27 sts and 30 rnds = 4" in 2×2 rib, all on size 5 needle.

## NOTES

- The tunic is worked in the round to the armholes, then divided for working the front and back separately. The live shoulder stitches are joined using the Kitchener stitch for a seamless finish.
- The loosely knit stockinette fabric is very elastic. For a more fitted look, choose a size with negative wearing ease.
- To become familiar with the smocking pattern, try making a practice swatch using a thicker yarn.

## Stitch Guide

**2×2 Rib:** (multiple of 4 sts)

**Rnd 1:** \*K2, p2; rep from \* around. Rep Rnd 1 for patt.

**6-Stitch Loop:** With yarn in back (wyb), insert right needle from front to back between 6th st (a knit st) and 7th st (a purl st) on left needle, wrap yarn around right needle as if to knit and draw a loop through to front of work. Place loop over first 6 sts on left needle with one side of loop in front of sts and other side of loop in back; extra st created by loop is between 6th and 7th sts. Pull yarn gently to cinch encircled sts tog and then work 6 sts and extra st from loop according to patt directions.

**Smocking Pattern:** (multiple of 8 sts + 2)

**Note:** In Rnd 3, the st before the first smock and the st after the last smock are worked differently to minimize the strain on each side of these outermost smocks.

**Rnds 1 and 2:** \*P2, k2; rep from \* to last 2 sts of smocked section, p2.

**Rnd 3:** P2, sl last st worked from right needle to left needle with yarn in front (wyf), bring yarn to back, return slipped st to right needle, \*6-st loop (see Stitch Guide), k2, p2, k1, k2tog (last encircled st tog with extra loop st after it), p2; rep from \* to last 8 sts of smocked section, 6-st loop, k2, p2, k2, p2tog (extra loop st tog with purl st after it), p1.

**Rnds 4–6:** Rep Rnd 1.

**Rnd 7:** P2, k2, p2, \*6-st loop, k2, p2, k1, k2tog (last encircled st tog with extra loop st), p2; rep from \* to last 4 sts of smocked section, k2, p2.

**Rnd 8:** Rep Rnd 1.

Rep Rnds 1–8 for patt.

## TUNIC

**Lower body:** With size 6 needle, CO 176 (192, 216, 232, 272) sts. Place marker (pm) and join in the rnd. [Knit 1 rnd, purl 1 rnd] 2 times. Change to St st and work even until piece measures 12 (12, 13, 13½, 14)" from CO. **Smocked waist:** Work in 2×2 rib (see Stitch Guide) for 4 rnds. Change to size 5 needle. **Set-up rnd:** Working in established rib, remove end-of-rnd m, k2, \*pm, work next 74 (74, 82, 90, 106) sts in rib patt to set up smocked section, pm, work 14 (22, 26, 26, 30) sts in rib patt for side of body; rep from \* once more—2 marked smocked sections at center front and back, each beg and ending with p2; one marked section at each side beg and ending with k2. Rnd beg at first smocked section. Working smocking patt (see Stitch Guide) over 74 (74, 82, 90, 106) sts in each smocked section, and cont 2×2 rib as established in side sections, work Rnds 1–8 of smocking patt 2 (2, 3, 3, 4) times, then work Rnds 1–4 once more. **Next rnd:** Removing m as you come to them, \*p2, k2; rep from \* to end; waist measures about 3½ (3½, 4½, 4½, 5¾)" high. **Upper body:** Work even in St st using size 5 needle until piece measures 5½ (5½, 6, 6, 7)" from top of waist. **Divide for armholes and neck:**

## DESIGNER TIPS

Weaving in ends can be tricky in laceweight garments worked in the round. I like to splice the ends together when joining a new ball of yarn to avoid weaving them in during finishing. It's easy to splice the yarn used for this project because it sticks to itself very well—just try ripping out a few stitches and you'll see what I mean! Achieving the correct tension when grafting with laceweight yarn can be tricky, too. Graft loosely and adjust the tension of the grafting after all the stitches have been joined.

K32 (32, 36, 39, 46), BO 10 (10, 10, 12, 14) sts for front neck, k37 (41, 47, 49, 58), BO 4 (4, 4, 6, 6) sts for right underarm, k84 (92, 104, 110, 130) sts for back, BO 4 (4, 4, 6, 6) sts for left underarm, k5 (9, 11, 10, 12) sts after BO gap, break yarn and sl the next 32 (32, 36, 39, 46) sts to right needle pwise for left front. Place 37 (41, 47, 49, 58) right-front sts and 84 (92, 104, 110, 130) back sts on separate holders—37 (41, 47, 49, 58) left-front sts rem.

## LEFT FRONT

With RS facing, rejoin yarn to 37 (41, 47, 49, 58) left-front sts. **Shape armhole and neck:**

**Row 1:** (RS) K2, ssk, knit to last 4 sts, k2tog, k2—2 sts dec'd.

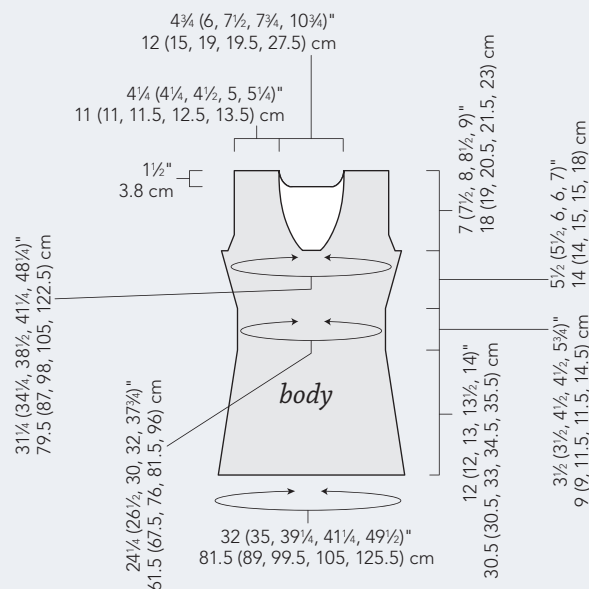

**Row 2:** (WS) Purl.

Rep last 2 rows 4 more times—27 (31, 37, 39, 48) sts rem.

**Row 1:** (RS) Knit to last 4 sts, k2tog, k2—1 st dec'd at neck edge only.

**Row 2:** (WS) Purl.

Rep last 2 rows 2 (6, 10, 10, 17) more times—24 (24, 26, 28, 30) sts rem. Work even until armhole measures 7 (7½, 8, 8½, 9)", ending with a WS row. Place sts on holder.

#### RIGHT FRONT

Return 37 (41, 47, 49, 58) held right-front sts to size 5 needle and rejoin yarn with WS facing. Purl 1 WS row. **Shape armhole and neck:**

**Row 1:** (RS) K2, ssk, knit to last 4 sts, k2tog, k2—2 sts dec'd.

**Row 2:** (WS) Purl.

Rep last 2 rows 4 more times—27 (31, 37, 39, 48) sts rem.

**Row 1:** (RS) K2, ssk, knit to end—1 st dec'd at neck edge only.

**Row 2:** (WS) Purl.

Rep last 2 rows 2 (6, 10, 10, 17) times—24 (24, 26, 28, 30) sts rem. Work even until armhole measures 7 (7½, 8, 8½, 9)", ending with a WS row. Place sts on holder.

#### BACK

Return 84 (92, 104, 110, 130) held back sts to size 5 needle and rejoin yarn with RS facing. **Shape armholes:**

**Row 1:** (RS) K2, ssk, knit to last 4 sts, k2tog, k2—2 sts dec'd.

**Row 2:** (WS) Purl.

Rep last 2 rows 4 more times—74 (82, 94, 100, 120) sts rem. Work even until armholes measure 5½ (6, 6½, 7, 7½)", ending

with a WS row. **Shape back neck:**

**Next row:** (RS) K27 (28, 30, 32, 34), BO center 20 (26, 34, 36, 52) sts, knit to end—27 (28, 30, 32, 34) sts each side. Place sts for right-back shoulder on holder. Cont on sts of left-back shoulder only, purl 1 WS row.

**Row 1:** (RS) K2, ssk, knit to end—1 st dec'd at neck edge.

**Row 2:** (WS) Purl.

Rep last 2 rows 2 (3, 3, 3, 3) more times—24 (24, 26, 28, 30) sts rem. Work even until armholes measure 7 (7½, 8, 8½, 9)", ending with a WS row. Place sts on holder. Return 27 (28, 30, 32, 34) held right-back shoulder sts to needle and rejoin yarn with WS facing. Purl 1 WS row.

**Row 1:** (RS) Knit to last 4 sts, k2tog, k2—1 st dec'd at neck edge.

**Row 2:** (WS) Purl.

Rep last 2 rows 2 (3, 3, 3, 3) more times—24 (24, 26, 28, 30) sts rem. Work even until armhole measures 7 (7½, 8, 8½, 9)", ending with a WS row. Place sts on holder.

#### FINISHING

Graft shoulder with Kitchener st (see Glossary). Block to measurements, allowing armhole edges to roll to WS.

**Neck edging:** With size 4 needle and WS facing (pick-up welt is deliberately on RS of garment), beg at center-back neck, pick up and knit 10 (13, 17, 18, 26) sts along BO edge (1 st for every BO st), 12 sts along right-back neck to shoulder join, 40 (43, 46, 49, 52) sts along right-front neck, 10 (10, 10, 12, 14) sts across center-front BO, 40 (43, 46, 49, 52) sts along left-front neck, 12 sts along left-back neck, and 10 (13, 17, 18, 26) sts across other half of back BO edge to end at center back—134 (146, 160, 170, 194) sts. Turn work so RS is facing, pm and knit 4 rnds. BO all sts loosely kwise. Allow edging to roll naturally to RS to cover pick-up welt, and slip-stitch in place if desired. Weave in ends. Block again, if necessary.

*Shelley Gerber* lives and knits in San Diego, California, with her husband and four children. Shelley graduated from the Ohio State University with a B.S. in industrial design. She has been knitting off and on since high school and seriously for the past five years. Her other interests include yoga and reading. You can follow her blog at [www.knamasteknitter.blogspot.com](http://www.knamasteknitter.blogspot.com).



# SAVE THE DATE!

Join the Interweave  
Editors for the  
ultimate learning  
experience for  
passionate knitters

**INTERWEAVE KNITTING LAB**, the knitting event you've been waiting for, is designed to explore every facet of our complex craft. Spend four days immersed in an inspirational and creative environment that will renew your passion for knitting.



## INTERWEAVE KNITTING LAB will inspire you with:

- Small technique and project-based classes, provocative panel discussions and fascinating lectures presented by knitting luminaries
- Rarely-offered classes on unique regional, ethnic, and historical techniques
- Studio classes that apply new design skills to original creations
- Instruction by icons of the knitting world including: **Barbara Walker, Nilda Callañaupa, June Hiatt, Clara Parkes, Ann Budd, Kathryn Alexander, and Shirley Paden**
- Special evening sessions and shopping in the Knitter's Market
- The place to meet and connect with knitters from all over the world who share your passion



**NOVEMBER 3-6, 2011**  
MARRIOTT SAN MATEO, CA  
(NEAR SAN FRANCISCO)

AT INTERWEAVE  
KNITTING LAB,  
YOU WILL  
EXPLORE TOPICS  
AND TECHNIQUES  
FROM ACROSS  
THE CENTURIES  
AND AROUND THE  
WORLD!

Sign up to learn more about Interweave Knitting Lab today!  
[www.InterweaveKnittingLab.com](http://www.InterweaveKnittingLab.com)

**ABBREVIATIONS**

beg	beginning; begin; begins
bet	between
BO	bind off
CC	contrasting color
cm	centimeter(s)
cn	cable needle
CO	cast on
cont	continue(s); continuing
dec(s)	decrease(s); decreasing
dpn	double-pointed needle(s)
fol	following; follows
g	gram(s)
inc	increase(s); increasing
k	knit
k1f&b	knit into front and back of same st
k2tog	knit two stitches together
knitwise	knitwise
LC	left cross
m(s)	marker(s)
MC	main color
mm	millimeter(s)
M1	make one (increase)
M1R (L)	make one right (left)
p	purl
p1f&b	purl into front and back of same st
p2tog	purl two stitches together
patt(s)	pattern(s)
pm	place marker
pssso	pass slipped stitch over
p2sso	pass two slipped stitches over
pwise	purlwise
RC	right cross
rem	remain(s); remaining
rep	repeat; repeating
rev St st	reverse stockinette stitch
rib	ribbing
rnd(s)	round(s)
RS	right side
rev sc	reverse single crochet
sc	single crochet
sk	skip
sl	slip
sl st	slip stitch (sl 1 st pwise unless otherwise indicated)
ssk	slip 1 kwise, slip 1 kwise, k2 sl sts tog tbl (decrease)
ssp	slip 1 kwise, slip 1 kwise, p2 sl sts tog tbl (decrease)
st(s)	stitch(es)
St st	stockinette stitch
tbl	through back loop
tog	together
WS	wrong side
wyb	with yarn in back
wyf	with yarn in front
yo	yarn over
*	repeat starting point (i.e., repeat from *)
**	repeat all instructions between asterisks
()	alternate measurements and/or instructions
[]	instructions that are to be worked as a group a specified number of times

**Cable Cast-On**

Begin with a slipknot and one knitted cast-on stitch if there are no established stitches. Insert right needle between first two stitches on left needle (Figure 1). Wrap yarn as if to knit. Draw yarn through to complete stitch (Figure 2) and slip this new stitch to left needle as shown (Figure 3).

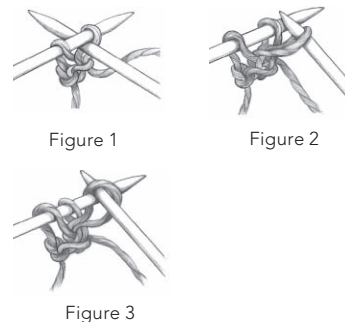

**Continental (Long-Tail) Cast-On**

Leaving a long tail (about 1/2" to 1" for each stitch to be cast on), make a slipknot and place on right needle. Place thumb and index finger of left hand between yarn ends so that working yarn is around index finger and tail end is around thumb. Secure ends with your other fingers and hold palm upward, making a V of yarn (Figure 1). Bring needle up through loop on thumb (Figure 2), grab first strand around index finger with needle, and go back down through loop on thumb (Figure 3). Drop loop off thumb and, placing thumb back in V configuration, tighten resulting stitch on needle (Figure 4).

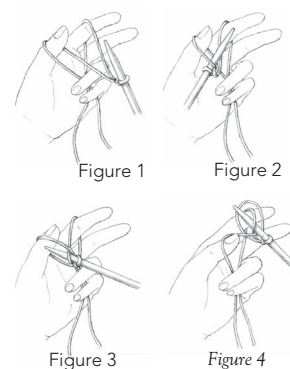

**I-Cord**

With double-pointed needle, cast on desired number of stitches. \*Without turning the needle, slide the stitches to other end of the needle, pull the yarn around the back, and knit the stitches as usual; repeat from \* for desired length.

**Invisible (Provisional) Cast-On**

Place a loose slipknot on needle held in your right hand. Hold waste yarn next to slipknot and around left thumb; hold working yarn over left index finger. \*Bring needle forward under waste yarn, over working yarn, grab a loop of working yarn (Figure 1), then bring needle to the front, over both yarns, and grab a second loop (Figure 2). Repeat from \*. When you're ready to work in the opposite direction, pick out waste yarn to expose live stitches.

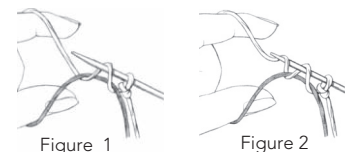

Find our full glossary online @ [knittingdaily.com](http://knittingdaily.com).

### Kitchener Stitch

**Step 1:** Bring threaded needle through front stitch as if to purl and leave stitch on needle.

**Step 2:** Bring threaded needle through back stitch as if to knit and leave stitch on needle.

**Step 3:** Bring threaded needle through first front stitch as if to knit and slip this stitch off needle. Bring threaded needle through next front stitch as if to purl and leave stitch on needle.

**Step 4:** Bring threaded needle through first back stitch as if to purl (as illustrated), slip this stitch off, bring needle through next back stitch as if to knit, leave this stitch on needle.

Repeat Steps 3 and 4 until no stitches remain on needles.

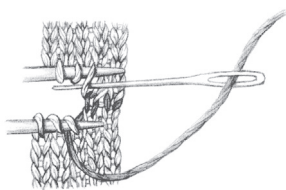

### Knitted Cast-On

Place slipknot on left needle if there are no established stitches.

\*With right needle, knit into first stitch (or slipknot) on left needle (Figure 1) and place new stitch onto left needle (Figure 2). Repeat from \*, always knitting into last stitch made.

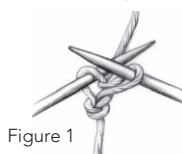

Figure 1

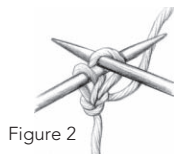

Figure 2

### Lifted Increases

#### Left Slant



#### Knit (LSI)

Knit into the back of stitch (in the “purl bump”) in the row directly below the stitch on the left needle.

#### Purl (LSPI)

Purl into the stitch in the row directly below the stitch on the left needle.

#### Right Slant

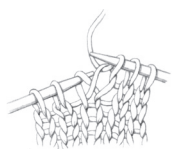

#### Knit (RSI)

Insert left needle into back of the stitch below stitch just knitted. Knit this stitch.

#### Purl (RSP)

Purl into stitch below stitch just purled.

### Mattress Stitch Seam

With right side of knitting facing, use threaded needle to pick up one bar between first two stitches on one piece (Figure 1), then corresponding bar plus the bar above it on other piece (Figure 2). \*Pick up next two bars on first piece, then next two bars on other (Figure 3). Repeat from \* to end of seam, finishing by picking up last bar (or pair of bars) at the top of first piece.



Figure 1



Figure 2



Figure 3

### Short-Rows: Wrapping a Stitch

Work to turn point, slip next stitch purlwise to right needle. Bring yarn to front for knit stitch (Figure 1) move yarn to back for purl stitch. Slip same stitch back to left needle (Figure 2). Turn work and bring yarn in position for next stitch, wrapping the stitch as you do so. *Note:* Hide wraps in a knit stitch when right side of piece is worked in a knit stitch. Leave wrap if the purl stitch shows on right side. Hide wraps as follows: *Knit stitch:*

On right side, work to just before wrapped stitch. Insert right needle from front, under the wrap from bottom up, and then into wrapped stitch as usual. Knit them together, making sure new stitch comes out under wrap. *Purl stitch:* On wrong side, work to just before wrapped stitch. Insert right needle from back, under wrap from bottom up, and put on left needle. Purl them together.

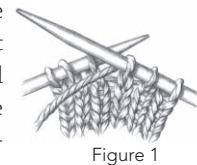

Figure 1

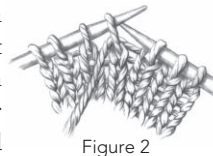

Figure 2

### Single Crochet (sc)

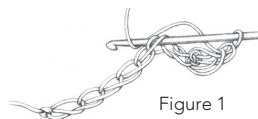

Figure 1

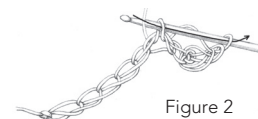

Figure 2

Insert hook into an edge stitch, yarn over hook and draw a loop through stitch, yarn over hook (Figure 1) and draw it through both loops on hook (Figure 2).

### Slip-Stitch Crochet (sl st)



Insert hook into stitch, yarn over hook and draw loop through stitch and loop on hook.

### Three-Needle Bind-Off

Place stitches to be joined onto two separate needles. Hold them with right sides of knitting facing together. Insert a third needle into first stitch on each of the other two needles and knit them together as one stitch. \*Knit next stitch on each needle the same way. Pass first stitch over second stitch. Repeat from \* until one stitch remains on third needle. Cut yarn and pull tail through last stitch.

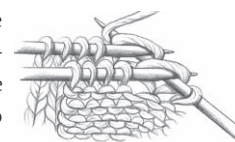

Contact these companies if you don't know of a local retailer or mail-order source for the yarns used in this issue.

## UNITED STATES YARN SOURCES

**2hl Buffalo Ranch/ Buffalo Gold**, (817) 330-9276; [www.buffalogold.net](http://www.buffalogold.net).  
**Blue Sky Alpacas**, (763) 753-5815; [www.blueskyalpacas.com](http://www.blueskyalpacas.com).  
**Brown Sheep Co.**, (800) 826-9136; [www.brownsheep.com](http://www.brownsheep.com).  
**Cascade Yarns**, [www.cascadeyarns.com](http://www.cascadeyarns.com).  
**Classic Elite Yarns**, (978) 453-2837; [www.classiceliteyarns.com](http://www.classiceliteyarns.com).  
**Fairmount Fibers/Manos del Uruguay**, (888) 566-9970; [www.fairmountfibers.com](http://www.fairmountfibers.com).  
**Green Mountain Spinnery**, (800) 321-9665; [www.spinnery.com](http://www.spinnery.com).  
**Harrisville Designs**, (603) 827-3333; [www.harrisville.com](http://www.harrisville.com).  
**Hazel Knits**, [www.hazelknits.com](http://www.hazelknits.com).  
**Lion Brand Yarn**, (800) 258-9276; [www.lionbrand.com](http://www.lionbrand.com).  
**Maggiknits**, (269) 903-2080; [www.maggiknits.com](http://www.maggiknits.com).  
**Mango Moon**, (989) 723-5259; [www.mangomoonyarns.com](http://www.mangomoonyarns.com).

**Plymouth Yarn Co.**, (215) 788-0459; [www.plymouthyarn.com](http://www.plymouthyarn.com).  
**Shibui Knits**, (503) 595-5898; [www.shibuiknits.com](http://www.shibuiknits.com).  
**Skacel Collection/Schulana**, (800) 255-1278; [www.skacelknitting.com](http://www.skacelknitting.com).  
**Tahki Stacy Charles Inc.**, (800) 338-YARN; [www.tahkistacycharles.com](http://www.tahkistacycharles.com).  
**Universal Yarn/Fibra Natura**, (877) 864-9276; [www.universalyarn.com](http://www.universalyarn.com).  
**WEBS/Valley Yarns**, (800) FOR-WEBS; [www.yarn.com](http://www.yarn.com).  
**Westminster Fibers/Rowan**, [www.westminsterfibers.com](http://www.westminsterfibers.com). In Canada: Diamond Yarn.

## CANADIAN SOURCES

**Diamond Yarn**, [www.diamondyarn.com](http://www.diamondyarn.com).  
**Louet North America**, (613) 925-4502; [www.louet.com](http://www.louet.com).

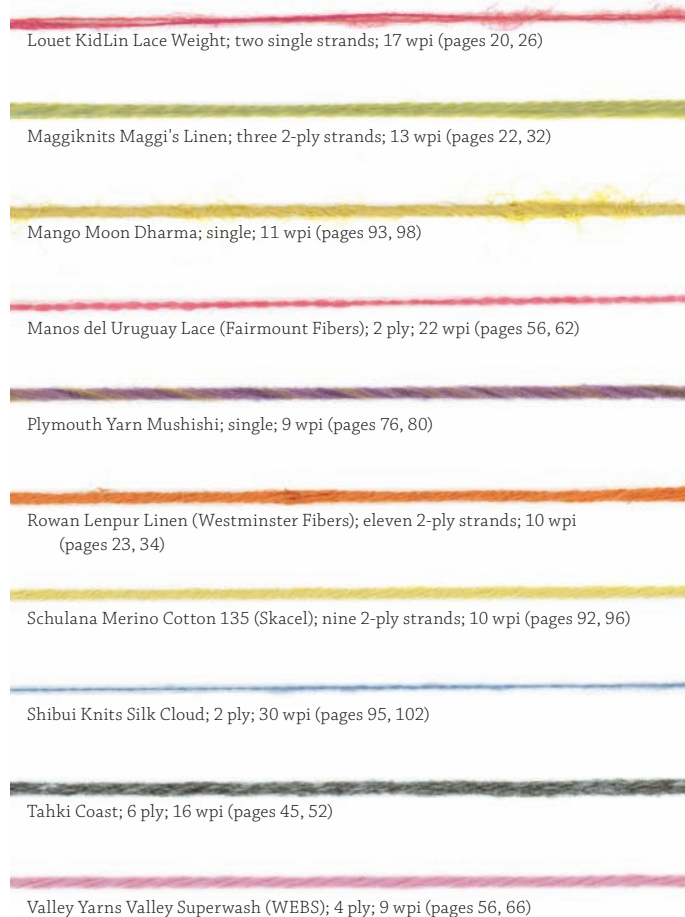

Yarns shown at 100% size.





Garden Plot Dress  
Victoria Myers  
pages 44, 46

## knitting connection • website listings

to advertise here call Stephanie Griess at (877) 613-4630

---

### PATTERNS

#### **Gardiner Yarn Works**

www.gardineryarnworks.com  
orders@gardineryarnworks.com

---

### SHOPS/MAIL ORDER

#### **Earth Guild**

www.earthguild.com  
(800) 327-8448

#### **Woobee KnitShop**

www.woobeeknitshop.com  
(800) 721-4080

---

### TRAVEL

#### **2011 Tours for Knitters & Friends**

www.joycejamestours.com  
(613) 695-0889  
(800) 267-5552

---

### WEBSITES TO VISIT

#### **Crayonbox Designs and Fibers**

www.crayonboxdesigns.com  
crayonbox@frontiernet.net

#### **Knit Purl**

www.knit-purl.com  
(503) 227-2999

#### **(866) 656-KNIT Lion Brand Yarn Company**

www.lionbrand.com  
(800) 258-YARN

#### **Peace, Love & Yarn**

www.peaceloveyarn.com  
(877) 795-9798

#### **Sweet Grass Wool**

www.sweetgrasswool.com  
(888) 222-1880

#### **The Elegant Ewe**

www.elegantewe.com  
(603) 226-0066

---

### YARNS

#### **Appalachian Yarns, Inc.**

www.AppalachianYarns.com  
Toni@appalachianyarns.com

#### **Berroco Yarns**

www.berroco.com  
info@berroco.com

#### **Gypsy Girl Creations**

www.stonebarnfibers.com  
(815) 968-1735

#### **Lanaknits Designs**

#### **Hemp for Knitting**

www.hempforknitting.com  
(888) 301-0011

#### **Paradise Fibers**

www.paradisefibers.net  
(888) 320-7746

#### **Skacel Collection Inc.**

www.skacelknitting.com  
(800) 255-1278

#### **Tahki/Stacy Charles Inc.**

www.tahkistacycharles.com  
(800) 338-YARN

#### **Wolle's Yarn Creations**

Color-Changing Cotton Yarns  
www.wollesyarncreations.etsy.com

#### **Wool2Dye4**

www.Wool2Dye4.com  
Yarnie@Wool2Dye4.com

#### **Yarns International**

www.yarnsinternational.com  
(800) YARNS-2U



# wrap yourself

## IN UNIQUE KNITS

A pioneer of unique and experimental construction, designer Kristin Omdahl is bringing her signature motifs and style to knitwear with *A Knitting Wrapsody*. The 18 original projects for scarves, wraps, shawls, and skirts explore shape, silhouette, and new ways of thinking about knitting pieces that wrap, drape, and tie. An included bonus DVD allows you to watch Kristin demonstrate the new and unique techniques needed to make the projects.



Kristin Omdahl designs knit and crochet garments and patterns under her label KRISTIN. She appears on *Knitting Daily TV*. Kristin's work has appeared in many magazines and books.

includes  
instructional  
DVD

**A Knitting Wrapsody**  
Innovative Designs to  
Wrap, Drape, and Tie  
Kristin Omdahl  
136 pages; 1-hour DVD  
978-1-59668-307-5  
\$24.95





## Knitting Pattern Books SHOE BOX DOLLS

Betty Lampen, Dept I

2930 Jackson St., San Francisco, CA 94115-1007

Books \$8 each—postage included  
CA residents include tax.

US funds only. Credit Card acc through PayPal.  
<http://www.bettylampenknitbooks.com>



Denise Interchangeable Cords...  
beyond blue and pink!

*Denise*  
INTERCHANGEABLE  
Knitting & Crochet  
THE ORIGINAL LOCKING CONNECTION

knitdenise.com  
888-831-8042

100% USA Made  
434-823-8234

*What's Missing? Your Ad. . .*



Contact Julie Macdonald at (970)-613-4612  
or [jmacdonald@interweave.com](mailto:jmacdonald@interweave.com)  
for more information



The Yarn Lounge...  
classes, accessories, and cool natural fibers

3003 west cary street  
Richmond, Virginia 23221  
tel 804 340 2880 | [theyarnlounge.com](http://theyarnlounge.com)

*it's hip to knit*



▶ Order a new magazine or subscribe to an old favorite

▶ Download FREE projects and patterns

▶ Discover exciting events to attend

Take a Look at  
[interweave.com](http://interweave.com)



the weaving works

basketry  
book arts  
dyeing  
knitting  
papermaking  
spinning  
surface design  
textile arts  
weaving

**the weaving works**

4717 Brooklyn Ave NE  
Seattle, WA 98105

supplies/classes/books

web site: [www.weavingworks.com](http://www.weavingworks.com) • e-mail: [weavingworks@speakeasy.net](mailto:weavingworks@speakeasy.net)  
orders: 1-888-524-1221 info: (206) 524-1221 fax: (206) 524-0250

ACCESSORIES



**della Q**  
Your Needle Case Resource  
[www.dellaQ.com](http://www.dellaQ.com)

Style #158-1

EVENT



**Finger Lakes Fiber Tour**

**September 14-18**  
Workshops  
Fiber Farm and Mill Visits  
607-535-9710

Registration information  
[www.fingerlakesfibers.com](http://www.fingerlakesfibers.com)

EVENTS



**Great Lakes Fiber Show**  
Wayne County Fairgrounds  
Wooster, Ohio

Saturday May 28 10am-5pm  
Sunday May 29 10am-4pm

Sales Booths with Fiber Related Supplies and Fiber Arts; Workshops; Skein Competition; Fleece Show and Sale; Sheep Show and Sale; Kids Activities; Fresh Cooked Lamb and MORE!

(330) 264-9665 • [don47linda@embarqmail.com](mailto:don47linda@embarqmail.com)  
[www.greatlakesfibershow.com](http://www.greatlakesfibershow.com)

INSTRUCTION



**LUCY NEATBY**  
*Make your stitches smile!*

**Three Cheers for Lucy!**  
Check out our 3 newest knitting DVDs

Toll-Free 1-866-272-7796 | [www.lucyneatby.com](http://www.lucyneatby.com)

ACCESSORIES



[www.tikabags.com](http://www.tikabags.com)

specializing in buttons, bags, and beads

**Tika**

totally indulgent knitting accessories

EVENTS



**Carolina Fiberfest**  
**MAY 20-22, 2011**  
NC STATE FAIRGROUNDS  
RALEIGH, NORTH CAROLINA  
[WWW.CAROLINAFIBERFEST.ORG](http://WWW.CAROLINAFIBERFEST.ORG)  
[WWW.HEELSIDEFARMS.COM](http://WWW.HEELSIDEFARMS.COM)

EVENTS



**10TH PAGOSA FIBER FESTIVAL**  
MAY 28TH & 29TH, 2011 PAGOSA SPRINGS TOWN PARK  
PAGOSA SPRINGS, COLORADO

WORKSHOPS  
YARN AND FIBER ARTS COMPETITIONS  
PURCHASE FIBER-RELATED PRODUCTS  
NAVAJO RUG AUCTION AND MORE

Visit [www.pagosafiberfestival.org](http://www.pagosafiberfestival.org) for more information

PATTERNS

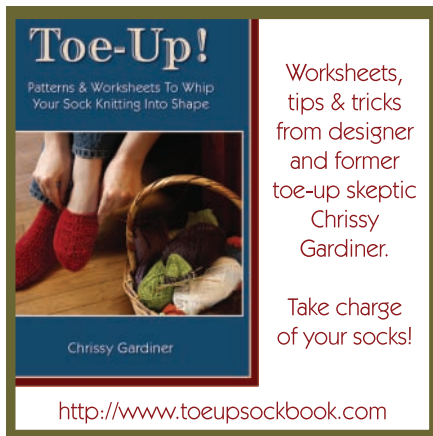

**Toe-Up!**  
Patterns & Worksheets To Whip Your Sock Knitting Into Shape

Worksheets, tips & tricks from designer and former toe-up skeptic Chrissy Gardiner.

Take charge of your socks!

Chrissy Gardiner  
<http://www.toeupsockbook.com>

EVENT



**DKC DOWNTOWN KNIT COLLECTIVE**

**14TH ANNUAL KNITTER'S FROLIC**

April 30-May 1, 2011  
Toronto, Ontario, Canada  
for all the details, visit [www.downtownknitcollective.ca](http://www.downtownknitcollective.ca)

the knitting, crocheting and spinning event of the year!

EVENTS



**The Fiber Event at Greencastle**

Putnam County Fairgrounds  
Greencastle, Indiana  
**April 15 & 16, 2011**  
1:00 pm to 7:00 pm Friday  
9:00 am to 5:00 pm Saturday  
\*Free Admission & Parking\*

**VENDORS • WORKSHOPS • COMPETITIONS**  
[TheFiberEvent.com](http://TheFiberEvent.com)

FIBERS



Visit the new [AbstractFiber.com](http://AbstractFiber.com) to see all our colors and fibers.

**Abstract Fiber**  
Hand-Painted Yarn & Fiber

PATTERNS



**ILGA LEJA**

*Knitting Luxury*  
**The Linen Collection**

902 425-2924  
[info@ilgaleja.com](mailto:info@ilgaleja.com)  
[www.ilgaleja.com](http://www.ilgaleja.com)

YARNS

**ARNILD'S KNITTING STUDIO**

84-4 **Rauma Yarn Distributor**

See all our patterns and yarn at [www.arnild.com](http://www.arnild.com)

Phone: 515-451-0584  
Email: [arnild@arnild.com](mailto:arnild@arnild.com)

YARNS

**EARTH GUILD**

33 Haywood St  
Asheville NC 28801  
1-800-327-8448

Tools • Books  
• Materials •  
for handcrafts

**Dragon Tale Yarns**  
[www.earthguild.com](http://www.earthguild.com)

YARNS

**Jisa Souza**  
www.jisaknit.com The Luxury of Color

YARNS

**The Warm Ewe**  
Visit us! 2 hours from Chicago

Fine Knitting Yarns, Beading & Needlepoint Supplies, & more!

31 Main Street, Chatham, NY  
[www.warmewe.com](http://www.warmewe.com)  
(518) 392-2929

YARNS

**AVRIL**  
Yarn and Crafts  
<http://www.avril-kyoto.com>

Please direct wholesale and retail inquiries to  
✉ [overseas@avril-kyoto.com](mailto:overseas@avril-kyoto.com)

YARNS

**habu textiles**

paper  
stainless steel  
hand-tied ramie  
pineapple, etc.

knit kits  
fabrics

[www.habutextiles.com](http://www.habutextiles.com) 212-239-3546

YARNS

"Yummy" Spring Knitting  
Just right for light-weight knits!

**Miss Babs Hand Dyed Yarn**  
[MISSBABS.COM](http://MISSBABS.COM)

YARNS

Have you tried it yet?

**Dye Your Own**

[www.Wool2Dye4.com](http://www.Wool2Dye4.com)

YARNS

**Creative Yarns**

...where fiber fanatics gather

Online Shopping:  
[www.creativeyarns.net](http://www.creativeyarns.net)

relax. indulge. create.

134 Speer Ave.  
Macon, GA 31204  
478.746.5648

Mon-Fri: 10am to 6pm  
Sat: 11am to 4pm  
Closed Sundays

YARNS

**Just Our Yarn**

luxurious handpainted yarns  
and weaving kits

[www.justouryarn.com](http://www.justouryarn.com)

YARNS

dedicated to nature, ethics and sustainability

**Mountain Meadow Wool**

**Knitting Yarns  
Premium US Merino Wool**

22 Plains Drive, Buffalo WY 82834  
[www.mountainmeadowwool.com](http://www.mountainmeadowwool.com)

YARNS

**The Yarn Barn LLC**  
Woodbridge, CT

Free Shipping On Kits Ordered From This Issue

[theyarnbarn.com](http://theyarnbarn.com)  
1-877-299-5245

## ALABAMA

**In the Making—Birmingham**[www.shopinthemaking.com](http://www.shopinthemaking.com)

Beautiful yarns &amp; fabrics! Unique patterns and friendly staff! Next to Starbucks!

3108 Heights Village (877) 298-1309

**Serendipity Needleworks  
—Tuscaloosa**[www.serendipityneedleworks.com](http://www.serendipityneedleworks.com)

Friendly, full-service knitting and needlepoint shop specializing in luxurious yarns, handpainted canvases, classes, finishing, and smiles!

412 Queen City Ave. (205) 758-0108

## ARIZONA

**Fiber Factory—Mesa**[www.fiberfactory.com](http://www.fiberfactory.com)

The Southwest's most complete yarn shop. Yarn, accessories, equipment, and classes.

216 W. Main St. (480) 969-4346

**Tempe Yarn and Fiber—Tempe**[www.tempeyarn.com](http://www.tempeyarn.com)

A gathering place for knitters, crocheters, spinners, weavers, and fiber artists. Wide selection of products, friendly classes, and staff.

1415 E. University Dr. #A102 (480) 557-9166

**Unique Designs by Kathy Withers  
—Tucson**[www.uniquedesignsbykathy.com](http://www.uniquedesignsbykathy.com)

Handspun art yarns in alpaca, llama, mohair, angora, wool from my animals. Classes/supplies: spinning, knitting, crochet, felting.

4010 W. Palo Seco (520) 572-3758

## CALIFORNIA

**Alpaca Direct—Brentwood**[www.AlpacaDirect.com](http://www.AlpacaDirect.com)

Huge selection of luxury yarn, roving, and knitting supplies. Classes and support.

144 Contiente Ave., Ste. 170 (925) 237-2575

**Unwind—Burbank**[www.unwindyarn.com](http://www.unwindyarn.com)

Where yarn lovers in Southern California congregate—you're always welcome! Unparalleled selection, service, workshops, events.

818 N. Hollywood Wy. (818) 840-0800

**Itza Knitterie—Glendale**[www.itzaknitterie.com](http://www.itzaknitterie.com)

Beautiful yarns, accessories, and classes for all levels. Sit and knit Thu evenings and Sat 1-4.

Call For New Address (818) 507-1813  
(323) 440-7454**The Yarn Boutique—Lafayette**[www.yarnboutique.us](http://www.yarnboutique.us)

Beautiful yarns; friendly, personal service; sensible prices. Located in La Fiesta Square near FedEx/Kinko's.

963-C Moraga Rd. (925) 283-7377

**Uncommon Threads—Los Altos**[www.uncommonthreadsyarn.com](http://www.uncommonthreadsyarn.com)Beautiful yarns from around the world.  
293 State St. (650) 941-1815**Knit Culture Studio—Los Angeles**[www.knitculture.com](http://www.knitculture.com)

Wide selection of unique and hand-dyed yarns, patterns, books, classes, and crafting supplies. Amazing customer service!

8118 W 3rd St. (323) 655-6487

**Piedmont Yarn & Apparel  
—Oakland**[www.piedmontyarn.com](http://www.piedmontyarn.com)

Local yarn, supplies, and classes for knitting, crochet, spinning, weaving, and felting. Friendly and helpful staff.

4171 Piedmont Ave., Ste.102 (510) 595-9595

**Knit This, Purl That!—Pleasanton**[www.yourknittingplace.com](http://www.yourknittingplace.com)Unique knitting shop in quaint downtown. Beautiful natural and blend yarns, supplies, and classes.  
yourknittingplace@comcast.net.

205 A Main St. (925) 249-9276

**Lake Tahoe Yarn Company  
—Truckee**[www.laketahoeyarn.com](http://www.laketahoeyarn.com)Serving the beautiful Truckee/Lake Tahoe area. Yarns, patterns, accessories, classes. A shop to enjoy.  
11008 Donner Pass Rd. (530) 587-1060

## COLORADO

**Knit One, Pearl Street—Bayfield**[www.knitonepearlstreet.net](http://www.knitonepearlstreet.net)

A full-service yarn shop nestled in the foothills of the Rocky Mountains of SW Colorado.

482 Pearl St. (970) 884-9008

**Table Rock Llamas Fiber Arts  
Studio Inc.—Colorado Springs**[www.tablerockllamas.com](http://www.tablerockllamas.com)

Knitting, crochet, spinning, weaving, felting, and dyeing.

6520 Shoup Rd. (866) 495-7747

**Bags By CAB Yarn Shoppe—Denver**[www.bagsbycab.com](http://www.bagsbycab.com)

Lunch Hour Classes - Crochet, Knitting &amp; Pattern reading.

1777 Larimer St., Ste. 102 (720) 473-2598

**Woolly Works Knit Shop—Elbert**

Retail-custom knitting, repairs, classes, fiber, cone yarns, limited knitting machine parts, maintenance, lessons. woollyworks\_farm@hotmail.com.

12285 Oregon Wagon Trl. (719) 495-2754

**Neota Designs—Estes Park**[www.neotadesigns.com](http://www.neotadesigns.com)

Handpainted yarn! 17 colorways in 18 yarn styles, plus alpaca, organic cotton in natural shades.

156 Wiest Dr. (970) 586-8800

**Desert Weyr LLC—Paonia**[www.desertweyr.com](http://www.desertweyr.com)

Black Welsh Mountain fleece, roving, locally produced yarns, and breeding stock. Farm tours by appointment.

16870 Garvin Mesa Rd. (970) 527-3573

## CONNECTICUT

**Mystic River Yarns LLC—Mystic**[www.mysticriveryarns.com](http://www.mysticriveryarns.com)

Basic to exotic yarns in a pleasant ambiance. Classes, workshops, and personal service by expert knitters.

14 Holmes St. (860) 536-4305

**Woolworks Ltd.—Putnam**[www.woolworksltd.com](http://www.woolworksltd.com)

A world of fiber at your fingertips.

154 Main St. (860) 963-1228

**Creative Fibers LLC—Windsor**[www.creativefibersonline.com](http://www.creativefibersonline.com)

Easy on/off I-91 between Hartford and Springfield. Wide selection for knitting and crochet. Evening and Sunday hours.

645A Poquonock Ave. (866) 669-YARN

## DISTRICT OF COLUMBIA

**Looped Yarn Works****—Washington, D.C.**[www.loopedyarnworks.com](http://www.loopedyarnworks.com)

A friendly, comfortable, and warm shop with a selection of beautiful yarns and notions. Great classes, workshops, knit-alongs, knit nights.

1732 Connecticut Ave. NW #200 (202) 714-5667

## FLORIDA

**The Knitting Garden—Coral Gables**[www.theknittinggarden.org](http://www.theknittinggarden.org)

An exceptional collection of fine yarns, patterns, and classes. Cozy and welcoming atmosphere for all!

2716 Ponce de Leon Blvd. (305) 774-1060

**Uncommon Threads—Palm Harbor**[uncommonthreads@tampabay.rr.com](mailto:uncommonthreads@tampabay.rr.com)

Catering to the fiber arts of knitting, crocheting, weaving, spinning.

31962 U.S. 19 N. (727) 784-6778

**A Good Yarn—Sarasota**[www.agoodyarnsarasota.com](http://www.agoodyarnsarasota.com)

There's something for everyone at A Good Yarn, Sarasota's ultimate creative spot for all things yarn!

7668 S. Tamiami Trail (941) 487-7914

## GEORGIA

**Creative Yarns—Macon**[www.creativeyarns.net](http://www.creativeyarns.net)

Unique and natural yarns for the discriminating fiber fanatic. Spinning, weaving and fibers for felting.

134 Speer Ave. (478) 7GO-KNIT

## ILLINOIS

**Mosaic Yarn Studio Ltd.**  
 –Des Plaines  
[www.mosaicyarnstudio.com](http://www.mosaicyarnstudio.com)

Helpful, knowledgeable staff; unique patterns and yarns, Addi Turbo needles, workshops, special events, classes.

1585 Ellinwood St. (847) 390-1013

**Knot Just Knits–Oak Park**  
[www.knotjustknits.com](http://www.knotjustknits.com)

The new nook for creative knitting, crocheting, and canvas-work no matter what your skill level.

1107-1109 Westgate (708) 948-7943

**Wool, Warp & Wheel–Richmond**  
[www.woolwarpandwheel.com](http://www.woolwarpandwheel.com)

Spinning, weaving, and knitting supplies and equipment. Tue–Fri 7 p.m.–9:30 p.m., Sat–Sun 10–5.

5605 Mill St. (815) 678-4063

## INDIANA

**Knitting Off Broadway**  
 –Fort Wayne

[www.knittingoffbroadway.com](http://www.knittingoffbroadway.com)

Located in a restored 1890's building, this full service yarn store specializes in unique, and hard to find fibers.

1309 Broadway (260) 422-YARN

**RiverWools . . . A Knitting Place**  
 –Terre Haute

[www.riverwools.com](http://www.riverwools.com)

If you knit, crochet, or would like to, you'll love our yarns, tools, books, and classes!

671 Wabash Ave. (812) 238-0090  
(866) 889-6657

## IOWA

**Knitted Together–West Des Moines**  
[www.knittedtogether.com](http://www.knittedtogether.com)

Enjoy an inspiring collection of yarns, patterns, and classes in a relaxing atmosphere.

7450 Bridgewood Blvd., Ste. 225  
(515) 222-YARN

## KANSAS

**Twist–Wichita**  
[www.twistyarnshop.com](http://www.twistyarnshop.com)

Everything for knit and crochet. Sit and stitch, wi-fi, and classes.

607 W. Douglas Ave. (316) 262-9276

## KENTUCKY

**Sophie's Fine Yarn Shoppe**  
 –Louisville

[www.sophiesfineyarn.com](http://www.sophiesfineyarn.com)

Friendly, full-service yarn shop. Come sit and knit!  
10482 Shelbyville Rd. Ste. 101

(502) 244-4927

**Enchanted Yarn & Fiber**  
 –Russellville

[www.enchantedyarnandfiber.com](http://www.enchantedyarnandfiber.com)

Offering natural yarns and fibers, spinning wheels, spinning and knitting supplies, and unique hand-crafted gifts.

399 C. Dodson Ln. (270) 772-1675

## MAINE

**The Stitching Mantis**  
 –Cape Elizabeth

[www.thestitchingmantis.com](http://www.thestitchingmantis.com)

Yarns, Needlepoint, Cross-stitch, Books: A wonderful shop for all needle-art enthusiasts. Gifts and infant clothing.

535 Shore Rd. (207) 767-5076

## MARYLAND

**Millicent's Yarns & More**  
 –Cumberland

[www.millicentsyarns.com](http://www.millicentsyarns.com)

Called one of the top 10 yarn shops on the East Coast. Two hours from Pittsburgh, Baltimore, and D.C. Easy on/off I-68 in western Maryland.

27 N. Centre St. (301) 722-8100

**A Tangled Skein–Hyattsville**

[www.atangledskein.com](http://www.atangledskein.com)

Fine yarns, knitting and crochet supplies, a comfortable atmosphere, friendly people, good advice.

5200 Baltimore Ave. (301) 779-3399

## MASSACHUSETTS

**The Woolpack–Acton**  
[www.woolpackyarn.com](http://www.woolpackyarn.com)

Yearn for Yarn? Unwind your mind and knit yourself silly in our cozy fiber mercantile.

Acton Woods Plaza/340 Great Rd.  
(978) 263-3131

**YARNS in the Farms**  
 –Beverly Farms

[www.yarnsinthefarms.com](http://www.yarnsinthefarms.com)

Best of Northshore Boston 2010. Cozy yarn shop and studio in seaside village. Inspiring classes/retreats.

641 Hale St. (978) 927-2108

**Stitch House–Dorchester**  
[www.stitchhousedorchester.com](http://www.stitchhousedorchester.com)

Very cool place to buy yarn, learn to knit, sew, crochet, or have a party.

846 Dorchester Ave. (617) 265-8013

**The Fiber Loft–Harvard**  
[www.TheFiberLoft.com](http://www.TheFiberLoft.com)

Knitting–Weaving–Spinning–Felting. Serving fiber enthusiasts for over 30 years. We have what you need!

9 Massachusetts Ave. (Rt. 111)  
(978) 456-8669

**The Sheep Shack–Holden**  
[www.thesheepshack.com](http://www.thesheepshack.com)

Fine yarns, friendly service, classes, rewards program, bargain bin, and the largest selection around.

787 Main St. (508) 829-5811

**Webs–America's Yarn Store**  
 –Northampton  
[www.yarn.com](http://www.yarn.com)

An amazing selection of yarns, super discounts, fast shipping, and simply the best service.

75 Service Center Rd. (800) 367-9327

**Cranberry Fiber Arts–S. Hamilton**  
[www.cranberryfiberarts.com](http://www.cranberryfiberarts.com)

The fiber collection to visit on Boston's North Shore.

161 Bay Rd. (Rte. 1A) (978) 468-3871

**Knit Purl–Sudbury**  
[www.knitpurlsudbury.com](http://www.knitpurlsudbury.com)

A unique yarn boutique. A large selection of quality yarns and knitting supplies. Classes, expert instruction, friendly service.

730 Boston Post Rd. (978) 443-5648

## MICHIGAN

**Yarn Garden–Charlotte**  
[www.yarngardenmichigan.com](http://www.yarngardenmichigan.com)

Vibrant colors, plush textures, inviting atmosphere, and great customer service. Let your creativity grow with us!

111 W. Lawrence Ave. (517) 541-9323

**City Knits–Detroit**  
[www.cityknits.com](http://www.cityknits.com)

The BEST place for yarn. Color nirvana, gourmet fibers, terrific tools! Fabulous location in the Fisher Building. Also in Mt. Clemens.

3011 W. Grand Blvd., Ste. 105  
(313) 872-9665

**Woven Art–East Lansing**  
[www.yarnandfiberart.com](http://www.yarnandfiberart.com)

Classes in knitting, crochet, spinning, and weaving. Excellent selection of artisan and hand-dyed yarns and fibers.

325B Grove St. (517) 203-4467

**Yarns & Threads–Lake Linden**  
[www.yarnsandthreads.com](http://www.yarnsandthreads.com)

Shepherd's Wool and beautiful needle cases made in Michigan-large assortment of needles and hooks.

332 Calumet St. (866) 296-9568

**City Knits–Mt. Clemens**  
[www.cityknits.com](http://www.cityknits.com)

The BEST place for yarn. Color nirvana, gourmet fibers, and terrific tools! One additional location in Detroit.

64 Cherry St. (586) 469-9665

## MINNESOTA

**All About Yarn–Coon Rapids**  
[www.allaboutyarn.biz](http://www.allaboutyarn.biz)

A specialty shop full of gorgeous yarn in a friendly, comfortable atmosphere. Offering classes.

455 99th Ave. NW, Ste. 180 (763) 785-4900

**Amazing Threads–Maple Grove**  
[www.amazing-threads.com](http://www.amazing-threads.com)

Unique yarn, textile, and fiber arts in NW suburbs. Knit and crochet classes.

11262 86th Ave. N. (763) 391-7700

**Shelley's Yarns & Fiber Shoppe  
-Taylors Falls**

[www.eweyarns.com](http://www.eweyarns.com)

Gorgeous natural fiber yarns to inspire! Free shipping on orders of \$75 or more!  
406 Bench St. (651) 465-6588

**MISSISSIPPI**

**Knit Studio LLC-Jackson**

[www.theknitstudio.com](http://www.theknitstudio.com)

Studio atmosphere with hand-dyed, upscale, natural yarns and fibers as well as nouveau knitting accessories.  
1481 Canton Mart Rd., Ste. B (601) 991-3099

**Knuttly Knitters-Yazoo City**

We carry over 60 lines of lovely yarns as well as books, needles, lessons, workshops, fellowship, and great fun.  
122 S. Main St. (662) 746-7555

**NEW HAMPSHIRE**

**Elegant Ewe-Concord**

[www.elegantewe.com](http://www.elegantewe.com)

Original designs and exceptional customer service. Featured in *Knitter's Stash* and selected by *Yankee Magazine* as a must-visit destination.  
71 S. Main St. (603) 226-0066

**The Fiber Studio-Henniker**

[www.fiberstudio.com](http://www.fiberstudio.com)

Natural fiber yarns for knitting and weaving, needles, books, looms, spinning wheels. Our own handpainted yarns.  
161 Foster Hill Rd. (603) 428-7830

**Ewe'll Love It!-Nashua**

[www.ewellloveit.com](http://www.ewellloveit.com)

Our motto is "inspire, indulge, instruct". Ewe'll Love It! is full of yarn, notions, chocolate...  
17 Factory St. (603) 578-2630

**Inspire 2 Knit & Tea-Plymouth**

[www.Inspire2knit.com](http://www.Inspire2knit.com)

A wonderful yarn shop, an amazing array of fibers and colors! Let us inspire you.  
12 Yeaton Rd. (603) 536-KNIT (5648)

**Grand View Country Store  
-Randolph**

"A unique yarn shop."

[www.grandviewcountrystore.com](http://www.grandviewcountrystore.com)

All your knitting and crocheting supplies and weekend retreats.  
89 U.S. Rt. 2 (603) 466-5715  
Out of state (800) 898-5715

**NEW JERSEY**

**Patricia's Yarns-Hoboken**

[www.patriciayarns.com](http://www.patriciayarns.com)

Beautiful natural fiber yarn shop located a stone's throw from Manhattan in the quaint Hudson river-front city of Hoboken.  
107 4th St. (201) 217-YARN

**Woolbearers-Mount Holly**

[www.woolbearers.com](http://www.woolbearers.com)

Full-service knitting, spinning, weaving, and dyeing shop specializing in handpainted fiber and yarns, spinning and weaving equipment.  
90 High St. (609) 914-0003

**NEW MEXICO**

**Miriam's Well-Santa Fe**

[www.sfschoolofweaving.com](http://www.sfschoolofweaving.com)

Santa Fe's premier yarn shop. Local, national, and international designer yarns.  
614 Paseo de Peralta (505) 982-6312

**NEW YORK**

**Spin A Yarn-Binghamton**

[www.spinayarn2knit.com](http://www.spinayarn2knit.com)

Traditional and unusual yarns, accessories, books, classes and the support needed to make any knitting project a success.  
9 Mitchell Ave. (607) 722-3318

**Yarn Cupboard-Jamesville**

[www.yarncupboard.com](http://www.yarncupboard.com)

Conveniently located 10 minutes from the center of Syracuse. Yarns, patterns/books, notions, buttons, accessories.  
6487 E. Seneca Tpk. (315) 399-5148

**Lion Brand Yarn Studio-New York**

[www.lionbrandyarnstudio.com](http://www.lionbrandyarnstudio.com)

Wide selection of Lion Brand Yarns, Free knit & crochet demonstrations, classes, special events.  
34 W. 15th St. (212) 243-9070

**The Yarne Source-Rochester**

[www.yarnsource.com](http://www.yarnsource.com)

Home of the Knit Parisian Tote and the hottest yarns in cold upstate NY. Remember: We leave no knitters behind.  
2080 E. Henrietta Rd. (585) 334-5350

**Pollywogs-Wayland**

[www.mypollywogs.com](http://www.mypollywogs.com)

Featuring Lamb's Pride Mill End yarns and more.  
7 Bush Ave. (585) 728-5667

**NORTH CAROLINA**

**Earth Guild-Asheville**

[www.earthguild.com](http://www.earthguild.com)

Yarns, needles, patterns for knitting. Materials, tools, books, and classes for traditional and contemporary handcrafts.  
33 Haywood St. (800) 327-8448

**The Tail Spinner-Richlands**

[www.tail-spinner.com](http://www.tail-spinner.com)

Complete fiber arts center: Quality yarns, spinning wheels, looms, classes, related tools, and equipment.  
109 N. Wilmington St. (910) 324-6166

**OHIO**

**Spin A Yarn Fiber Garden-Marion**

[www.spinayarnfibergarden.com](http://www.spinayarnfibergarden.com)

Hand-dyed yarn, felting kits, Cascade, HiyaHiya, books, classes. Lots of unique items. Ashford dealer. Located in Charleston Place Shops.  
187 W. Center St. (740) 382-6969

**Smith Furnishings-Oberlin**

Showcasing fine yarn, books, supplies, and lessons. On the Historic Square in Downtown Oberlin.  
25 W. College St. (440) 774-2371

**OREGON**

**Knot Another Hat-Hood River**

[www.knotanotherhat.com](http://www.knotanotherhat.com)

Your source for everything hip and knit worthy! Find fine yarns, needles, accessories, gifts, and more!  
16 Oak St., Ste. 202 (541) 308-0002

**Knit Purl-Portland**

[www.knit-purl.com](http://www.knit-purl.com)

A boutique for the avid knitter, located in historic downtown Portland. Our product collection highlights rare and unique treasures from around the world.  
1101 SW Alder St. (866) 656-KNIT

**Knitting Bee-Portland Westside**

[www.theknittingbee.com](http://www.theknittingbee.com)

We LOVE yarn! Friendly customer service and a fabulous selection of yarns for knitting/crochet. 15 minutes west of Portland, off Hwy. 26.  
18305 NW W. Union Rd. (503) 439-3316

**PENNSYLVANIA**

**Silverbrook Fiber Arts & Sheepskins  
-Marchand**

[www.silverbrookfiberarts-sheepskin.com](http://www.silverbrookfiberarts-sheepskin.com)

Ten rooms of fiber-arts equipment (knitting, crochet, weaving, spinning) including 4 rooms of yarn in restored 1860 home. Classes. Punxsutawney/Indiana area.  
16040 U.S. Hwy. Rt. 119 N. (724) 286-3317

**String Thing Shop-Mountain Top**

[www.stringthingshop.com](http://www.stringthingshop.com)

Yarn, string, and other fun things. Sit n Knit Wednesday nights. Easy access from I-81 and I-80.  
58 S. Mountain Blvd. (570) 474-6542

**Natural Stitches-Pittsburgh**

[www.naturalstitches.com](http://www.naturalstitches.com)

Best selection of natural fibers in Pittsburgh. Knowledgeable staff. Open 7 days. Evenings, too!  
6401 Penn Ave. (412) 441-4410

**Glory-ous Knits-Watsontown**

[www.glory-ousknits.com](http://www.glory-ousknits.com)

Top brands; natural, exotic fibers; the best yarns; and more from all over the world.  
15 Harris Cir. (570) 437-4139

## RHODE ISLAND

**Fresh Purls Ltd.—Providence**  
www.freshpurls.com

A yarn store just for you, offering classes, fine yarns, needles, notions, books, and patterns. Please visit us in the store.

769A Hope St. (401) 270-8220

## TENNESSEE

**Bliss Yarns—Brentwood**  
www.blissyarns.com

Just south of Nashville off I-65, you'll find a friendly and helpful staff to assist with all your fiber needs.

127 Franklin Rd. (615) 370-8717

**Smoky Mountain Spinnery—Gatlinburg**  
www.smokymountainspinnery.com

Come shop in our comfortable surroundings. Everything for spinning, weaving, knitting, crocheting, and needlefelting. Antiques and gifts, too.

466 Brookside Village Wy., Ste. 8 (865) 436-9080

## TEXAS

**Yarntopia—Katy**  
www.yarntopia.net

Yarntopia carries a multitude of specialty yarns that are sure to please every crafter. Stitching groups and classes available.

2944 S. Mason Rd., Ste. M (281) 392-2386

**Rose Path Weaving—Lindale**  
www.rosepath.net

In east Texas, just off I-20 on Hwy. 69N. High-quality yarn in natural fibers. Skacel and Brittany knitting needles.

2808 S. Main St., #E (903) 882-3234

**WC Mercantile—Navasota**  
www.wcmercantile.com

"The BEST little Wool shop in Texas!" Featuring natural fibers for knitting and spinning. Lots of local Texas yarns, too!

201 E. Washington Ave. (936) 825-3378

**The Woolie Ewe—Plano**  
www.woolieewe.com

Largest selection of yarn in the Southwest. E-mail info@woolieewe.com.

1301 Custer Rd., #328 (972) 424-3163

## UTAH

**Blazing Needles—Salt Lake City**  
www.blazing-needles.com

Blazing Needles, your friendly Sugarhouse community gathering place. Yarns to inspire. Classes—everyone welcome.

1365 S. 1100 E. (801) 487-5648 (KNIT)

## VIRGINIA

**fibre space™—Alexandria**  
www.fibrespace.com

Visit our fresh and funky shop space featuring specialty yarns just outside Washington, D.C.

102 N. Fayette St. (703) 664-0344

**The Yarn Lounge—Richmond**  
www.theyarnlounge.com

A comfortable atmosphere, friendly regulars, helpful staff, and plenty to satisfy your natural fiber needs. It's hip to knit.

3003 W. Cary St. (804) 340-2880

## WASHINGTON

**Paradise Fibers—Spokane**  
www.paradisefibers.net

Terrific selection of wool yarn, knitting needles, wheels and looms. Order online or stop in. Same day shipping!

225 W. Indiana Ave. (888) 320-7746

## WISCONSIN

**The Dragonfly Yarn Shop—Janesville**  
www.dragonflyyarnshop.com

Wool and luxury fibers. Addi and Crystal Palace needles. Lessons by the hour. Home of the Pirouette!

1327 N. Wright Rd., Ste. 5A (608) 757-9228

**Loop Yarn Shop—Milwaukee**  
www.loopyarnshop.com

Loop supports all knitters and crocheters in their creative fiber endeavors and aspirations!

2963 N. Humboldt Blvd. (414) 265-2312

## WYOMING

**The Fiber House—Sheridan**  
www.thefiberhouse.com

Fleece to fashion and fun! Local alpaca yarn. Books, notions, classes, and 30+ yarn lines! info@thefiberhouse.com.

146 Coffeen Ave. (307) 673-0383

## CANADA—BRITISH COLUMBIA

**Needle & Arts Centre—Campbell River**  
www.needleart.com and  
www.needlearts.blogspot.com

Wide selection of yarns, top consulting, Knit Café, patterns, accessories. Importers of Surina Needles and shawl pins. Mail orders North America.

910 Island Hwy. (888) 588-7834

**Twist of Fate Yarns—Kamloops**  
www.twistoffateyarns.com

Fine yarns, exquisite fibres, wheels, looms and more for spinners, knitters, weavers, dyers, felters, and crocheters.

2020-F Falcon Rd. (778) 471-5562

## CANADA—NEW BRUNSWICK

**London-Wul Shop/Studio/Farm—Lakeburn**  
www.thewoolworks.com

Eastern Canada's most complete store for knitters/spinners/weavers. Producers of exquisite fibers and yarns. Canada's Economuseum of Handspinning.

1937 Melanson Rd. (506) 382-6990

## CANADA—ONTARIO

**the knit cafe—Toronto**  
www.theknitcafetoronto.com

Original patterns; colorful, natural, local yarns and knitting accessories; one-of-a-kind gifts; and knitting classes.

1050 Queen St. W. (416) 533-5648

## ONLINE

**Enchanted Knoll Farm**  
www.enchantedknoll.etsy.com

Hand-dyed yarns and fibers created on our farm in Maine. Also at www.enchantedknoll.com.

## EVENTS

**3RD ANNUAL SPRING YARN KNIT & CROCHET EVENT!** May 20, 2011, 11:00 am. Yarn Shoppe, 1777 Larimer St., Denver, CO. Exhibitors, Activities, Classes! Free! [www.BagsByCAB.com](http://www.BagsByCAB.com).

**ALPACA FIBER GALORE! 2011 MAPACA JUBILEE**—PA Farm Show Complex, Harrisburg, PA, April 8–10. Second largest alpaca show in U.S.; learn about the animals and their fiber, visit alpaca owners, and watch alpaca and fiber judging. MAPACA store featuring regionally produced yarn and fiber products. Enter the handspun skein and fiber-arts competitions. For more info, visit [www.MAPACA.org](http://www.MAPACA.org) and click on JUBILEE SHOW or e-mail [trishtylerdavis@verizon.net](mailto:trishtylerdavis@verizon.net). Free Admission!

**COLUMBIA GORGE FIBER FESTIVAL.** Hood River, Oregon. April 15–17. \*Classes, Vendors & More\* <http://www.lavendersheep.com/cgff.html>. Hope to See You There!

## INSTRUCTION

**WWW.DEGOATSNISHEPRANCH.COM** Bayfield, Colorado; (970) 884-0502. Stay in cabin at beautiful mountain sheep ranch. Spinning and knitting lessons, Wensleydale and mohair fiber available.

## KNITTING NEEDLES

**SWALLOW CASEIN, KNITTING NEEDLES,** "Flexible yet firm, smooth, effortless knitting." Made from milk. Retail and wholesale. (319) 367-5065; [clfadw@gmail.com](mailto:clfadw@gmail.com); [www.countrylanefiberarts.homestead.com/Home](http://www.countrylanefiberarts.homestead.com/Home).

## STITCHING SERVICES

**GhostStitchers PROFESSIONAL STITCHING SERVICE** for your knitting, crochet, cross-stitch, crewel, hardanger, pulled threads, embroidery, and needlepoint projects. [www.ghoststitchers.com](http://www.ghoststitchers.com).

## TRAVEL

**2011 TOURS for KNITTERS and FRIENDS.** Memorable travel since 1995. Watch our website for details of this year's unique itinerary to Scotland. Limited tour size. Don't miss out! [www.joycejames.com](http://www.joycejames.com). (613) 695-0889; (800) 267-5552.

**BEHIND THE SCENES ADVENTURES: 2011 TEXTILE TOURS** with the Experts! Peru and Bolivia (Easter in Andes), with Nancy Thomas; also Eastern Turkey, May; Laos and Cambodia, July. [www.btsadventures.com](http://www.btsadventures.com); [lacynthia@vom.com](mailto:lacynthia@vom.com); (510) 275-3662.

**CRAFT CRUISES**—Join us on a knitting trip! Hawaii with Myra Wood and Kristine Brooks, Norwegian Fjords and Scandinavia with Sally Melville, Bermuda with Judy Pascale, Canadian Rocky Rail, with Joan Schrouder, Alaska with Jared Flood and Lorilee Beltman, Canada New England with Donna Druchunas and Joan Schrouder, China's Yangtze River, with Lily Chin, Christmas Craft Markets along the Danube with Karen Alfke, Knit & Ski in Steamboat Springs with Cat Bordhi & Lucy Neatby, and South America with Mary Jane Mucklestone & Cynthia LeCount. Visit [www.craftcruises.com](http://www.craftcruises.com) or call 877-97-CRAFT.

**UK & IRELAND TOURS & RESOURCES FOR FIBER & FOOD LOVING TRAVELERS.** June 2011: England/Scotland with knitting workshops on Arran Island. **Handcrafted Holidays**, (253) 476-3040; [handcraftedholidays@yahoo.com](mailto:handcraftedholidays@yahoo.com); [www.handcraftedholidays.com](http://www.handcraftedholidays.com).

## WEBSITES TO VISIT

**WWW.ABBEYYARNS.COM** 2-ply, worsted-weight yarn, imported from Ireland, sold direct to knitters. Request color card online, view yarn, patterns, kits, buttons.

**WWW.WOOL2DYE4.COM** Exclusive line of undyed yarns and roving for hand-dyers. Make your work stand out! Wholesale inquiries welcome. [Yarnie@Wool2Dye4.com](mailto:Yarnie@Wool2Dye4.com).

If you are reading this,  
**so are your  
customers!**

Contact Julie Macdonald for  
advertising information  
[jmacdonald@interweave.com](mailto:jmacdonald@interweave.com) or  
970-613-4612

## Advertisers' Index

Abstract Fiber . . . . .	112	Loopy Ewe, The . . . . .	75
Alpaca Yarn Company, The . . . . .	67	Lorna's Laces . . . . .	75
Arnhold's Knitting Studio . . . . .	113	Louet North America . . . . .	31
Ashford Handicrafts Ltd. . . . .	53	Malabrigo Yarn . . . . .	33
Avril . . . . .	113	Mango Moon . . . . .	67
Be Sweet . . . . .	65	Mannings, The . . . . .	91
Bergere de France . . . . .	13	MissBabs: Hand-Dyed Fiber Goods . . . . .	113
Berroco . . . . .	6	Mountain Meadow Wool . . . . .	113
Betty Lampen . . . . .	111	Pagosa Fiber Festival . . . . .	112
Blue Moon Fiber Arts . . . . .	59	Paradise Fibers . . . . .	ibc
Blue Sky Alpacas . . . . .	5	Patternworks/Keepsake Quilting . . . . .	51
Brown Sheep Company . . . . .	27	Personal Threads Boutique . . . . .	71
Bryson Distributing (Friendly Products) . . . . .	65	Prism Arts Inc. . . . .	51
Carolina Fiber Fest. . . . .	112	Quayside Publishing Group . . . . .	51
Carolina Homespun . . . . .	59	Sakonnet Purls . . . . .	59
Cascade Yarns . . . . .	29, 39, 61, 63, 89	Sanguine Gryphon Fiber Arts . . . . .	69
ChiaoGoo . . . . .	81	ShibuiKnits . . . . .	43
Classic Elite Yarns . . . . .	bc	Signature Needle Arts . . . . .	49
Crafts Americana (Knit Picks) . . . . .	35	Skacel Collection Inc. . . . .	3, 69
Creative Yarns . . . . .	113	Straker Classics . . . . .	65
Della Q . . . . .	112	Strauch Fiber Equipment Co. . . . .	69
Denise Interchangeable Knitting Needles . . . . .	111	Synergo Arts . . . . .	71
Downtown Knit Collective . . . . .	112	Tahki Stacy Charles . . . . .	ifc
Earth Guild . . . . .	113	Tika Bags . . . . .	112
Fairmount Fibers Ltd. . . . .	10-11	tilli tomas yarns . . . . .	69
Favor Software . . . . .	15	TNC Enterprises . . . . .	91
Fiber Event, The . . . . .	112	Tradewind Knitwear Designs . . . . .	112
Finger Lakes Fiber Tour . . . . .	112	Tunney Wool Company / O-Wool . . . . .	91
Frog Tree Yarns . . . . .	47	Universal Yarn . . . . .	47
Gardiner Yarn Works . . . . .	112	Wagtail Yarns . . . . .	61
Great Lakes Fiber Show . . . . .	112	Warm Ewe, The . . . . .	113
Green Mountain Spinnery . . . . .	111	Weaving Works . . . . .	111
Habu Textiles . . . . .	113	Web*Sters . . . . .	67
Halcyon Yarn . . . . .	39	Webs-America's Yarn Store . . . . .	43
Ilga Leja Handknit Design . . . . .	112	Westminster Fibers . . . . .	17
Interweave . . . . .	71, 81, 85, 87, 89, 97, 105, 110, 111	Westport Yarns . . . . .	91
Jade Sapphire Exotic Fibres . . . . .	67	Wool 2 Dye 4 . . . . .	113
Jimmy Beans Wool . . . . .	49	XRX Stitches . . . . .	61
Just Our Yarn . . . . .	113	Yarn Barn of Kansas . . . . .	63
Kaleidoscope Yarns . . . . .	75	Yarn Barn, The . . . . .	113
Kelbourne Woolens (The Fibre Co) . . . . .	65	Yarn Lounge, The . . . . .	111
Kentucky Sheep and Fiber Festival . . . . .	75	Yarnsisters . . . . .	47
Knit Nation . . . . .	37		
Knitting at Knoon Designs . . . . .	61		
Lion Brand Yarn Co. . . . .	63		
Lisa Souza Knitwear and Dyeworks . . . . .	113		



uncommon *Flax* • Block by Block • *Fabric Interrupted* • mod\*u\*lar • Circumnavigated



En Pointe Pullover  
pages 20, 26



V-Yoke Cardigan  
pages 21, 28



Gathered Front Tank  
pages 22, 32



Heliotropic Pullover  
pages 23, 34



Swirl Crop Jacket  
pages 24, 36



Garden Plot Dress  
pages 44, 46



Cranberry Island Throw  
pages 45, 50



Rain on the Prairie Scarf  
pages 54, 58



Leaf and Picot Cardigan  
pages 55, 58



Rose Lace Stole  
pages 56, 62



Tatiana's Sweater  
pages 56, 66



Drop Mesh Tee  
pages 57, 70



Curvy Squares Tee  
pages 76, 80



Hexagon Petal Tee  
pages 77, 83



Diminishing Gore Skirt  
pages 78, 88



Pinkerton Shawl  
pages 79, 90



Lara Bubble Top  
pages 92, 96



Draped Vest  
pages 93, 98



Ruched Yoke Tee  
pages 94, 100



Gossamer Smocked Tunic  
pages 95, 102

# Darn!

SIGRID ARNOTT

*My mom threaded my first needle and taught me to sew. My grandmum sat with her arm around me and instructed me in knitting. But it was my dad who taught me to darn.*

Because my dad worked outside every day in Montana's varying weather, he became a great believer in wool socks. He told me that on at least one subzero day, even though he had fallen through ice and gotten soaked, his toes didn't freeze because he was wearing his wool socks. On wet days, wool socks might *get damp*, but they still *felt warm*. And, as a welder, he had noticed that unlike other fibers, wool didn't burn or even melt from stray sparks. I've since learned the science behind both of those facts, but, for my dad, his experience alone was reason enough for him to invest in wool.

So my brothers, my sister, and I could always count on getting several pairs of wool socks for Christmas, as well as a few more pairs throughout the winter. If we had to work outside on a cold, wet day, we put on wool socks. If we went skiing, wool socks. After I left home, if I complained of being cold, I would get a package of wool socks in the mail. Even when I lived halfway around the world in a country known for its fine wool, the socks from home still arrived.

Although my grandmum was a great knitter, she could not have kept us all in stockings, so my dad stocked up on wool socks for the family at Don's Western Outdoor Store or the Montana Woolen Shop. Sometimes the socks were soft and cushy, but more often they were simple rag wool socks that wore thin at the heels, leaving the most sensitive part of the foot exposed to cold and prone to blisters.

So my dad gave me another gift: He taught me how to darn. I suppose most people who grew up during the Depression knew how to darn, but most of them didn't take the time to pass the skill on to their teenage children. He showed me how to put a lightbulb in a sock, stretch

the fabric over its smooth surface, and sew a reinforcing square around the hole. He then demonstrated how to stitch a warp of yarn across the worn knitting and weave in perpendicular weft threads to fill the hole. He would add a couple of diagonal lines for extra strength, and the sock was better than before—if, perhaps, a bit lumpy.

After I became a sock knitter, I learned that this darning method is "wrong." You're supposed to be able to reknit the area or use duplicate stitch to reinforce it. I also acquired darning tools to help me do it better—a darning egg and special yarn needles with curved tips.

The first socks I ever made took so long to knit and were so precious that I wanted only the best for them. I painstakingly reknitted their first holes with leftover yarn. After fixing several weak spots over time, I ripped the feet out completely, discarding the worn yarn. I used high-strength sock yarn to reknit the heels and toes and reused the remaining original yarn with a strand of reinforcement thread for the rest of the feet. This repair held up for some time. Now I see that my first and favorite pair of socks is in need of repair again.

I could, of course, do it the "right" way, with the official tools. But as I sit down to the task, I find myself reverting to my dad's method. I find it easier, more familiar, less fussy. I even prefer a big slippery lightbulb to my antique wooden darning egg. I suppose, too, that I am attached to a method I learned from someone I loved.

When I reknit, I always struggle with the needle, trying to remember which way to go. When I darn, I simply weave "under, over, under, over." With the familiar, comfortable rhythm, my mind is free to wander a bit—and I remember it all. ■

*Sigrid Arnett* lives with her family of guys in Minneapolis and blogs about her handmade analog life at [www.analogme.typepad.com](http://www.analogme.typepad.com).



**Wool Pak**  
 Natural Heathers  
 8, 10 & 14 Ply  
 250g Monster Hanks  
 Starting at \$16.99



**FREE SHIPPING!**  
 ORDERS OVER \$100



Super Yarn Swift V2  
 With Lantern Moon  
 Muslin Carry Bag  
 \$65.00

Spinning Wheel  
 Packages Starting  
 at \$330!



Family Owned  
 & Operated



1-888-320-7746

*Paradise Fibers*

paradisefibers.net

# Classic Elite Yarns

*Dianthus*

**Provence**

Egyptian cotton yarn

*Garden Gate* pattern booklet

[classiceliteyarns.com/IWKS11.html](http://classiceliteyarns.com/IWKS11.html)

To mail-order *Garden Gate* send \$10.95 to:

Classic Elite Yarns

122 Western Ave. Dept: IWKS11

Lowell, MA 01851

